

ALPHADECK

Panel Slab Formwork System

Instructions for Assembly and Use – Standard Configuration – Version 2.0

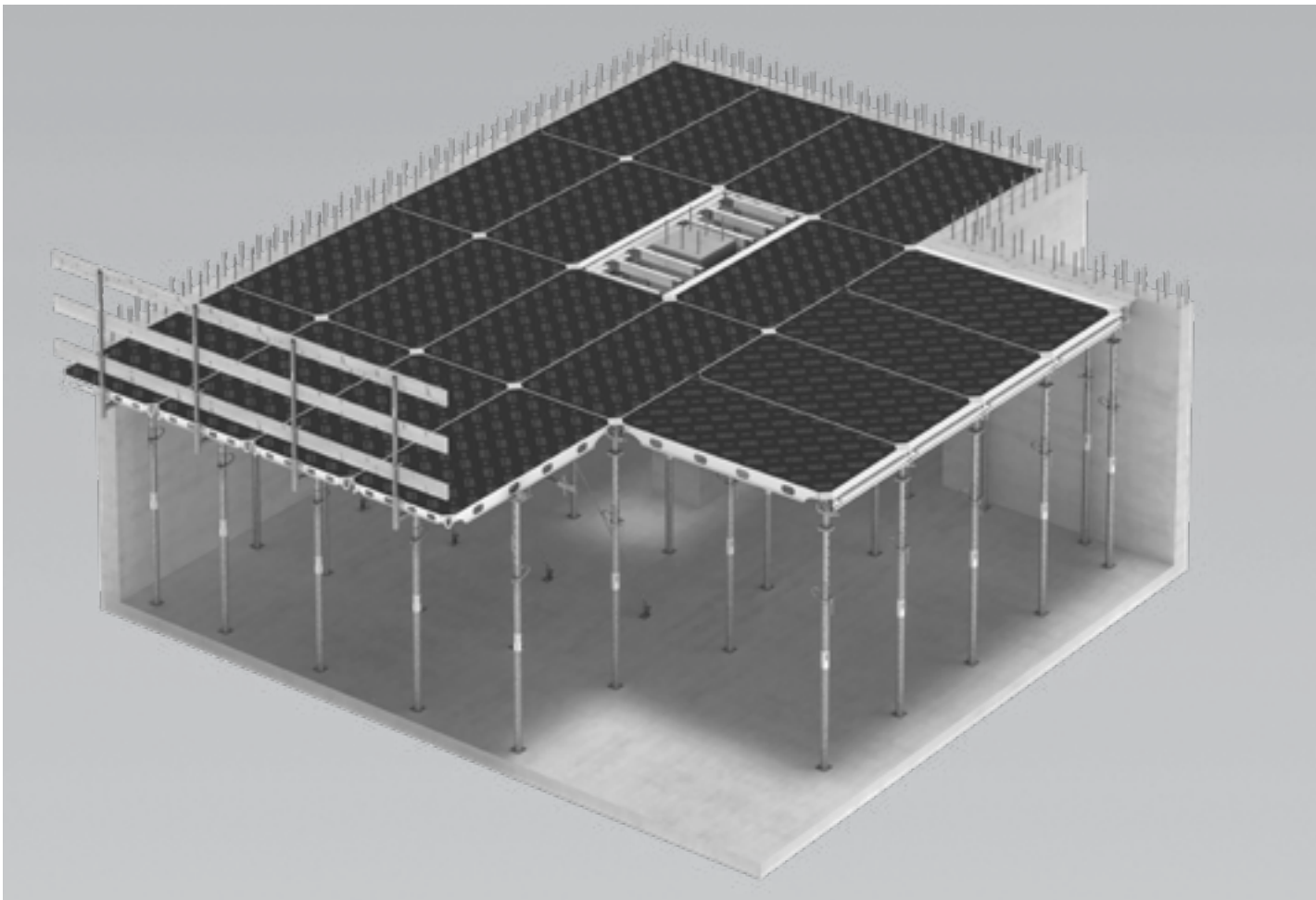

Overview

Main components	4
Key	5

Introduction

Target groups	6
Additional technical documentation	6
Intended use	7
Instructions for Use	7
Cleaning and maintenance instructions	8

Safety instructions

Cross-system	9
System-specific	11
Storage and transportation	12

Component overview

Component overview	13
--------------------	----

General

A1 Storage and transportation	14
Pallet AD	14
Fixing the castor wheels to pallet AD	15
Transporting the panels	16
Stacking aid AD	17
Crate pallet 80 x 120	19
A2 System components	20
Panel ADP	20
Drophead ADH	21
Slab props	22
Brace ADB	23
Shuttering aid AD	24
Filler beam ADF	25
Filler beam ADF with ADF-P nailing insert	25
Guardrail holder ADG with guardrail post HSGP-2	26
Corner insert AD	27
Notes for static calculations	29
A3 Design information	30
Prop loads in panel system	30
A4 Shuttering	32
General	32
Starting bay	33
Shorter direction	35
Longer direction	36
Guidelines for the brace ADB	39
A5 Checklist	40
A6 Infill areas	43
Transverse and longitudinal infills	43
Infill at slab panel corner	45
Infill at wall end using corner insert AD	47
Infill at wall internal corner	49
Infill at beam internal corner	50
A7 Shuttering around the column	51
Columns within the panel grid	51
A8 Change of direction	53
Using corner insert AD	53
A9 Guardrails	55
Guardrail holder ADG with guardrail post HSGP-2	55

A10 Cantilevers	57
Cantilever in longer direction of the panel	57
Cantilever in shorter direction of the panel	60
A11 Striking	63
When early striking is required	63
When early striking is not required	68
Stripping tool AD	69
Striking guide values	73

Slab props

B1 Load charts for slab props	74
PEP 20	74
PEP 30	75
PEP Ergo B	76
PEP Ergo D	77
PEP Ergo D	78
PEP Ergo D	79
MULTIPROP 250, 350, 480, 625	80
PEP Alpha, PEP Alpha-2	81

Program overview

ALPHADECK Panel Slab Formwork	82
-------------------------------	----

Main components

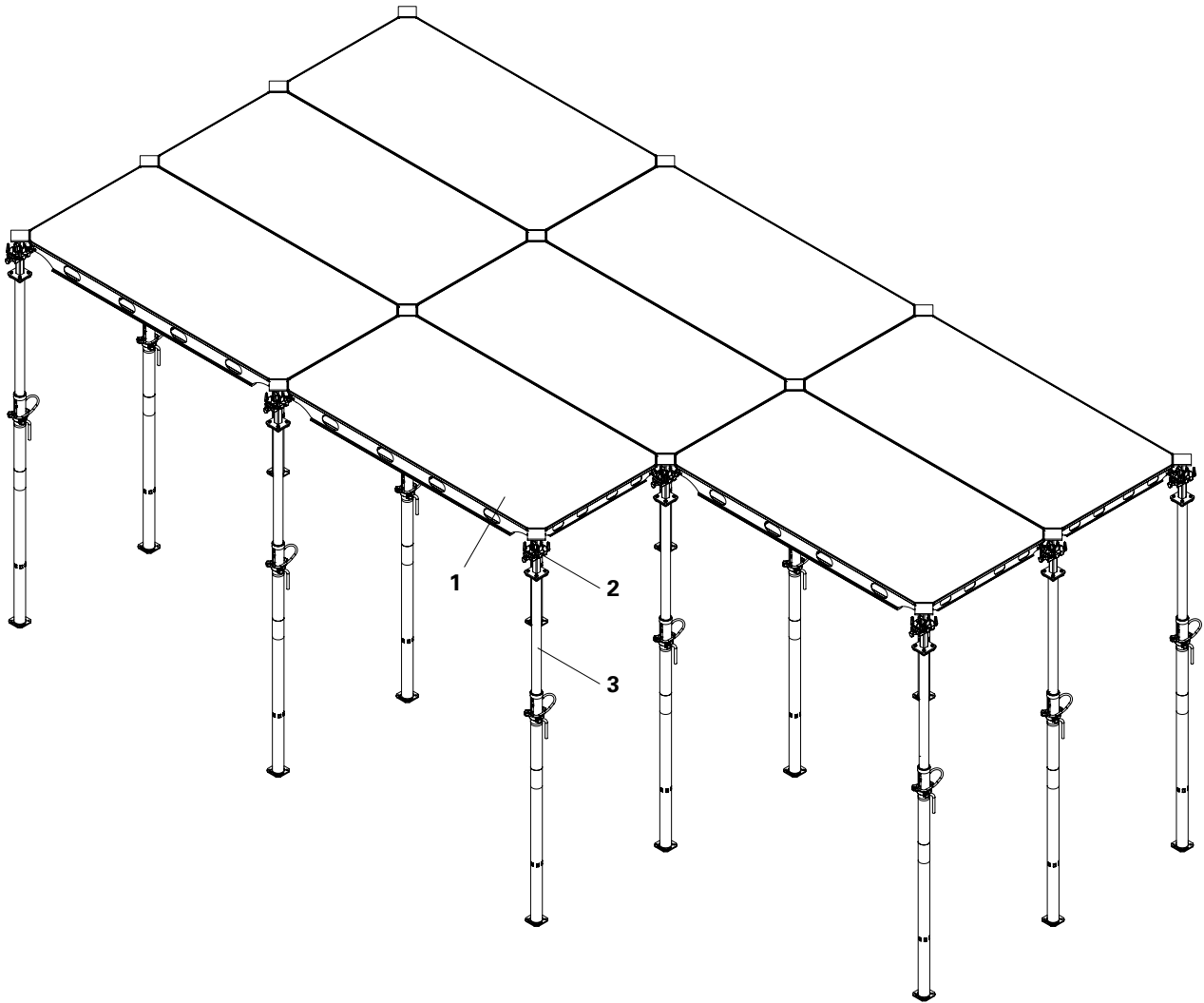

- 1 Panel ADP
- 2 Drophead ADH
- 3 Prop

Key

Pictogram | Definition



Danger/Warning/Caution



Note



To be complied with



Load-bearing point



Visual inspection



Tip



Incorrect use



Safety helmet



Safety shoes



Safety gloves



Safety goggles



Personal protective equipment to prevent falling from a height (PPE)

Arrows



Arrow representing an action



Arrow representing a reaction of an action*



Arrow representing forces

* If not identical to the action arrow.

Safety instruction categories

The safety instructions alert site personnel to the risks involved and provide information on how to avoid these risks. Safety instructions can be found at the beginning of the section or before instructions for action and are highlighted as follows:



Danger

This sign indicates an extremely hazardous situation which could result in death or serious, irreversible injury if the safety instructions are not followed.



Warning

This sign indicates a hazardous situation which could result in death or serious, irreversible injury if the safety instructions are not followed.



Caution

This sign indicates a hazardous situation which could result in minor or moderate injury if the safety instructions are not followed.



Note

This sign indicates situations in which failure to observe the information can result in material damage.

Format of the safety instructions



Signal word

Type and source of hazard!
Consequences of non-compliance.

⇒ Preventative measures.

Dimensions

Dimensions are usually given in cm. Other measurement units, e.g. m, are shown in the illustrations.

Conventions

- Instructions are numbered with: 1., 2., 3.
- The result of an instruction is shown by: →
- Position numbers are clearly provided for the individual components and are given in the drawing, e.g. **1**, in the text in brackets, for example **(1)**.
- Multiple position numbers, i.e. alternative components, are represented with a slash: e.g. **1/2**.

Notes on illustrations

The illustration on the front cover of these instructions is understood to be a system representation only. The assembly steps presented in these Instructions for Assembly and Use are shown in the form of examples with only one component size. They are valid for all component sizes contained in the standard configuration.

To facilitate understanding, detailed illustrations are sometimes incomplete. The safety equipment that might not be shown in these detailed illustrations must nevertheless be available.

Target groups

Contractor

These Instructions for Assembly and Use are designed for contractors who either

- assemble, modify and dismantle PERI systems, or
- use them, e.g. for concreting, or
- allow them to be used for other operations, e.g. carpentry or electrical work.

Competent person

(Construction Site Coordinator)
The Safety and Health Protection Coordinator*

- is appointed by the client,
- must identify potential hazards during the planning phase,
- determines measures that provide protection against risks,
- creates a safety and health protection plan,
- coordinates the protective measures for the contractor and site personnel so that they do not endanger each other,
- monitors compliance with the protective measures.

Competent persons qualified to carry out inspections

Due to the specialist knowledge gained from professional training, work experience and recent professional activity, the competent person qualified to carry out inspections has a reliable understanding of safety-related issues and can carry out inspections correctly. Depending on the complexity of the inspection to be undertaken, e.g. scope of testing, type of testing or the use of certain measuring devices, a range of specialist knowledge is necessary.

Qualified personnel

PERI systems may only be assembled, modified or dismantled by personnel who are suitably qualified to do so. Qualified personnel must have completed a course of training** in the work to be performed, covering the following points at least:

- Explanation of the plan for the assembly, modification or dismantling of the formwork in an understandable form and language.
- Description of the measures for assembling, modifying or dismantling the formwork.

- Designation of the preventive measures to be taken to avoid the risk of persons and objects falling.
- Designation of the safety precautions in the event of changing weather conditions that could adversely affect the safety of the system, as well as the personnel concerned.
- Details regarding permissible loads.
- Description of all other risks and dangers associated with assembly, modification or dismantling operations.



- **In other countries, ensure that the relevant national guidelines and regulations in the respective current version are complied with!**
- **If no country-specific regulations are available, it is recommended to proceed according to German guidelines and regulations.**
- **A competent person must be present on site during system operations.**

* Valid in Germany: Regulations for Occupational Health and Safety on Construction Sites 30 (RAB 30).

** Instructions are given by the contractor themselves or a competent person selected by them.

Additional technical documentation

- Brochure/Flyer:
 - ALPHADECK
- Instructions for Assembly and Use:
 - MULTIPROP Slab Props
 - PEP Ergo Slab Props
 - PEP Alpha and Alpha-2 Props
- Instructions for Use:
 - Pallets and Stacking Devices
 - Pallet Lifting Trolley
 - PERI Bio Clean
- Data Sheet: Anchor Bolt PERI 14/20 x 130
- PERI Design Tables – Formwork and shoring

Intended use

Area of application

PERI products have been designed for exclusive use in the industrial and commercial sectors only by suitably trained personnel.

Product description

PERI ALPHADECK is a modular slab panel formwork system which allows fast as well as safe forming operations with a systematic assembly sequence. The system provides efficient solutions for constructing slab thicknesses up to 55 cm.

The unique design of the system offers safe and confident erection from the level below.

The formlining used is high performance film coated birch plywood of 9 mm thickness.

Accessories for infill areas, shuttering around columns and for the slab edges are also available.

The ALPHADECK panel frames are made of high strength and durable aluminum alloy which helps to keep the maximum panel weight below 50 kg.

Due to early striking, the panels can be used for the new concreting cycle. Only the props with dropheads remain in position until full concrete strength has been reached. On-site material requirements are therefore clearly reduced.

Due to large sized panel, one prop can support up to 2.88 m² of slab area. This saves on both materials and working time.

ALPHADECK system has been designed in all respects to ensure that only a minimum of cleaning effort is required. This guarantees additional time-savings.

For supporting the ALPHADECK panels, all PERI Props may be used subject to slab thickness and ceiling height in accordance with the "Load charts for slab props" for ALPHADECK system.

Technical data

System dimensions

The PERI ALPHADECK slab formwork system is designed for slab thickness up to:

- 35 cm for 240 x 120 cm panel size
- 55 cm for 180 x 120 cm panel size

Evenness: Line 6 according to DIN 18202, see Section "A3 Design information" on page 30.

For permissible prop loads, see Section "B1 Load charts for slab props" on page 74.

Accessories dimensions

The standard ALPHADECK filler beams of sizes 120 / 180 / 240 cm suits the standard panels.

The ALPHADECK bracings are of sizes 120 / 180 / 240 cm.

Instructions for Use

Use in a way not intended, deviating from the standard configuration or the intended use according to the Instructions for Assembly and Use, represents a misapplication with a potential safety risk, e.g. risk of falling.

Only PERI original components may be used. The use of other products and spare parts is not allowed and represents a misapplication with associated safety risks.

Changes to PERI components are not permitted.

The system described in these Instructions for Assembly and Use may contain patent-protected components.

Cleaning and maintenance instructions



Warning

- Splintering parts / concrete residue could cause injuries to the eyes and hands!
 - ⇒ Wear safety goggles.
 - ⇒ Wear safety gloves.

In order to maintain the value and operational readiness of the formwork materials over the long term, clean the panels after each use.

Some repair work may also be inevitable due to the tough working conditions.

The following instructions should help to keep cleaning and maintenance costs as low as possible. Spray the formwork on both sides with concrete release agent before each use; this facilitates easier and faster cleaning of the formwork.

Spray the concrete release agent very thinly and evenly.

Spray the rear side of the formwork with water immediately after concreting; this avoids any time-consuming and costly cleaning operations.

When used continuously, spray the formlining elements with concrete release agent immediately after striking; then clean by means of a scraper, brush or rubber lip scraper. Important: do not clean formlining made of plywood with high-pressure equipment. This could result in the formlining being damaged.

Fix recesses and built-in parts with double-headed nails; as a result, the nails can easily be removed later, and damage to the formlining is largely avoided.

When placing bundles of reinforcement bars or other heavy objects on horizontally stored formwork elements, suitable support, e.g. square timbers, is to be used: this prevents impressions and damage to the formlining to a large extent.

Internal concrete vibrators should be fitted with rubber caps if possible; as a result, any damage to the formlining is reduced if the vibrator is accidentally inserted between the reinforcement and formlining.

Never clean powder-coated components, e.g. elements and accessories, with a steel brush or hard metal scraper; this ensures that the powder-coating remains intact.

Use spacers for reinforcement with large-sized supports or extensive areas of support; this largely avoids impressions being formed in the formlining when under load.

Cross-system



Safety instructions apply to all service life phases of the system.

General

The contractor must guarantee that the Instructions for Assembly and Use supplied by PERI are available at all times and understood by the site personnel.

These Instructions for Assembly and Use can be used as the basis for creating a risk assessment. The risk assessment is compiled by the contractor. The Instructions for Assembly and Use are not a substitute for a risk assessment!

Observe and comply with the safety instructions and permissible loads.

For the application and inspection of PERI products, the current safety regulations and guidelines valid in the respective countries must be observed.

Materials and working areas are to be inspected before each use and assembly, for:

- damage,
- stability and
- Functional correctness.

Damaged components must be exchanged immediately on site and may no longer be used.

Safety components are to be removed only when they are no longer required.

When on slab formwork, scaffolds and working platforms:

- do not jump,
- do not run,
- do not drop anything from or onto it.

Components provided by the contractor must comply with the characteristics stipulated in these Instructions for Assembly and Use and all applicable laws and standards. Unless otherwise indicated, the following applies in particular:

- Timber components: Strength class C24 for solid wood according to EN 338.
- Scaffolding tubes: galvanised steel tubing with minimum dimensions of $\varnothing 48.3 \times 3.2$ mm according to EN 12811-1:2003 4.2.1.2.
- Scaffolding tube couplings according to EN 74-1 and EN 74-2.

Deviations from the standard configuration are only permitted after a further risk assessment has been carried out by the contractor.

Appropriate measures for working and operational safety, as well as stability, are defined on the basis of this risk assessment.

Corresponding proof of stability can be provided by PERI on request, if the risk assessment and resulting measures to be implemented are made available.

Before and after extraordinary events that may have damaging effects on the safety of the formwork system, the contractor shall immediately

- produce another risk assessment and make use of its results to take suitable steps to guarantee the stability of the formwork system,
- arrange for an extraordinary inspection to be carried out by a competent person qualified to do so. The aim of this inspection is to identify and rectify any damage in good time in order to guarantee safe use of the formwork system.

Exceptional events could be:

- accidents,
- long periods of non-use,
- natural events, e.g. heavy rainfall, icing, heavy snowfall, storms or earthquakes.

Assembly, modification and dismantling work

Assembly, modification or dismantling of formwork systems may only be carried out by qualified persons under the supervision of a competent person. The qualified personnel must have received appropriate training for the work to be carried out with regard to specific risks and dangers.

On the basis of the risk assessment and Instructions for Assembly and Use, the contractor must create installation instructions, in order to guarantee safe assembly, modification and dismantling of the formwork unit.



The contractor must ensure that the personal protective equipment required for the assembly, modification or dismantling of the slab formwork, e.g.

- safety helmet,
- safety shoes,
- safety gloves,
- safety goggles,

is available and used as intended.



If personal protective equipment against falling from a height (PPE) is required or specified in local regulations, the contractor must determine appropriate attachment points on the basis of the risk assessment.

The PPE to be used to prevent falling is determined by the contractor.

The contractor must

- provide safe working areas for site personnel, which are to be reached through the provision of safe access ways. cordon off and clearly mark danger zones.
- guarantee stability during all stages of construction, in particular during assembly, modification and dismantling operations.
- ensure and demonstrate that all loads that occur are safely transferred.

Use

Every contractor who uses or allows formwork systems or sections of the formwork to be used, has the responsibility for ensuring that the equipment is in good condition.

If the formwork system is used successively or at the same time by several contractors, the health and safety coordinator must point out any possible mutual hazards and all work must be then coordinated.

System-specific



Safety instructions apply to all service life phases of the system.

Strike components only when the concrete has sufficiently hardened and the person in charge has given the go-ahead for striking to take place.

The load-bearing capacity of the slabs that have been completed must be activated so as to avoid overloading of the slab props during vertical concreting cycles. For this, free deflection capability is required for these components.

This can be done by releasing and reinstalling all slab props available.

The load-distributing support used, such as planking, must match the respective base. If several layers are required, planks are to be arranged crosswise.

The existing prop loads (see Tables) must be safely transferred by means of sufficiently load-bearing slab props or shoring systems.

If the shuttering height is more than 3 m, then it is recommended that the shuttering be carried out using mobile scaffold.

The formwork surface area may only be accessed or loaded when the system is secured with the bracing.

The ALPHADECK bracings are to be provided for horizontal stability of the system during erection and should not be removed until deshuttering.

The stability of the total system relies upon the soffit being locked in to the permanent structure such as wall and columns.

Where the permanent works will not provide sufficient restraint to the system, additional bracing shall be introduced by tubes and fittings or ALPHADECK bracings.

Do not remove the bracing until proper authority is given.

Single post shores more than one tier high shall not be used wherever greater shore heights are required, consult the shoring supplier.

If slab props with mounted dropheads fall over or are otherwise used improperly, this may result in damage to the drophead.

As a result, dropheads could fail during further use and cause serious injuries to site personnel.

Dismantle dropheads after incorrect use and check for any signs of damage, e.g. cracked flyplate or wedge. Damaged components must not be used!

The horizontal fixed position of the slab formwork must be guaranteed. The transfer of the horizontal loads has to be guaranteed by means of other measures supplied by the contractor, e.g. anchor chains or bracing. Load assumptions for horizontal loads in accordance with DIN EN 12812.

Anchoring is to take place only if the anchorage has sufficient concrete strength.

When storing heavy items on the formwork, the load-bearing capacity must be taken into consideration.

Cantilevers may only be accessed after the panels are securely anchored using anchor chains.

When wind speeds reach 28 km/h and more, panels can lift off and the slab formwork can collapse. Falling components can strike personnel and seriously injure them.

To avoid such an incident:

- Apply ballast to the slab formwork.
- Dismantling the formwork for unfavourable structure geometries.

Storage and transportation

Store and transport components ensures that no unintentional change in their position is possible. Detach lifting accessories and slings from the lowered components only if they are in a stable position and no unintentional change is possible.

Do not drop the components.

Use PERI lifting accessories and slings as well as only those load-bearing points provided on the component.

During the moving procedure ensure that components are picked up and set down so that unintentional falling over, falling apart, sliding, falling down or rolling is avoided. no persons are allowed to remain under the suspended load.

Always guide pre-assembled scaffolding bays, scaffolding units or scaffolding sections with ropes when moving them by crane.

Dismantled components should be stacked in a planned manner and distributed to avoid concentrated loads on the partially cured concrete.

The access areas on the construction site must be free of obstacles and tripping hazards as well as being slip-resistant.

For transportation, the surface must have sufficient load-bearing capacity.

Use original PERI storage and transport systems, e.g. crate pallets, pallets or stacking devices.

Component overview

Pos. no.	Component name
1	Panel ADP
2	Drophead ADH
3	Prop
4	Pallet AD
5	Crate pallet 80 x 120
6	Shuttering aid AD
7	Brace ADB
8	Filler beam ADF
9	Guardrail holder ADG
10	Guardrail post HSGP-2
11	Plywood
12	MFX Crosshead
13	Cross beam head ADI
14	Timber [50 x 100 mm]
15	Guardrail boards
16	Crosshead ADC
17	Anchor chain 3.0 kN
18	Turn buckle 3.0 kN
19	Base plate RS
20	Pin and cotter pin
21	Anchor bolt PERI 14/20 x 130
22	Z-bracings
23	Timber block
24	Stacking aid AD
25	Corner insert AD
26	Stripping tool AD
27	ADF-P nailing insert
28	Girder VT20



- Instructions for Use for PERI pallets and stacking devices must be taken into consideration.
- Manually-created transportation units must be correctly stacked and secured.
- Pallets and stacked items are to be protected against the effects of the weather, e.g. panels secured against lifting by means of tension belts.
- Always attach crane lifting gear to all load-bearing points.

Pallet AD

PERI ALPHADECK pallets (4) are suitable for lifting by crane or forklift.



- Lashing straps are manufactured according to DIN EN 12195-2, and are to be regularly checked in accordance with this standard.
- Use crane slings (4.1) to position the long panel sides at the side of the pallet AD (4). (Fig. A1.01)
- Use all four attachment points for crane slings (4.1) when transporting by crane. (Fig. A1.01)
- Do not mix the stacks. Always ensure that the stacks are of equal height on each transport pallet.
- Always turn the formlining side upwards so that water can drain off.

Fig. A1.01

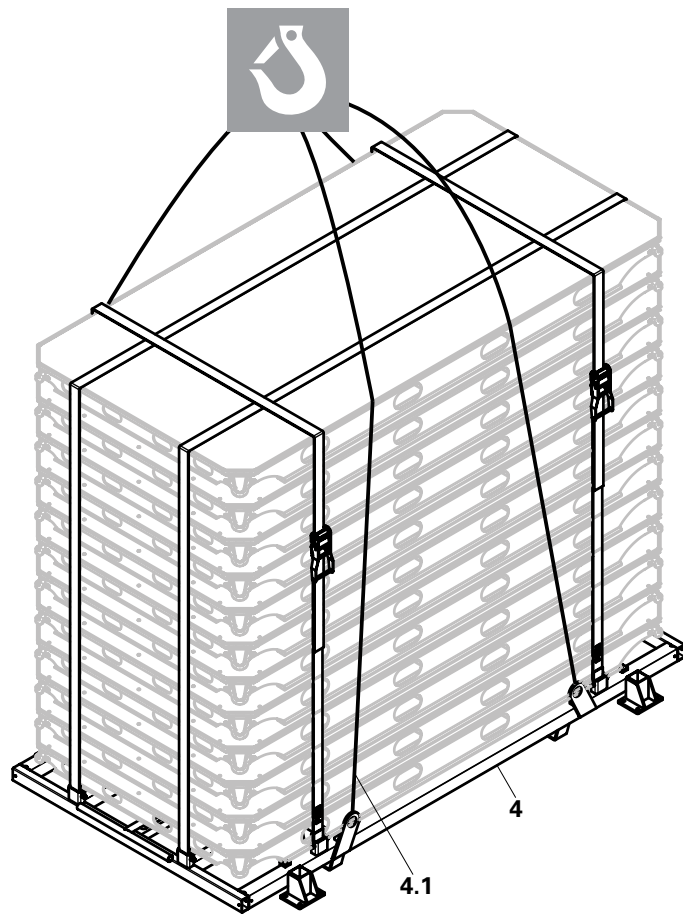

Capacity

A maximum of 12 panels on top of each other per stack.

The maximum height of single pallet stack should not exceed 2.2 m.

Pallet AD 240: 12 pieces (ADP 240)
 Total weight (single stack excluding pallet weight): max. 600 kg

Pallet AD 180: 12 pieces (ADP 180)
 Total weight (single stack excluding pallet weight): max. 500 kg

Fixing the castor wheels to pallet AD

The pallet AD (4) can also be attached with castor wheels (art. no.: 111690) and therefore can be moved manually in horizontal direction.

Assembly

1. Keep the pallet AD (4) on PERI workbench (qty. 2) (art. no.: 065051) or any suitable workbench.
2. Insert the four numbers of M10 x 30 bolts (4.2) (art. no.: 116436) at each wheel location. (Fig. A1.02a)
3. Attach the castor wheel (4.3) (art. no.: 111690) to the bolts (4.2) and tighten it with the four numbers of M10 nut (4.4) (art. no.: 710234). (Fig. A1.02b + Fig. A1.02c)
4. Repeat the similar procedure at each location. (Fig. A1.03)

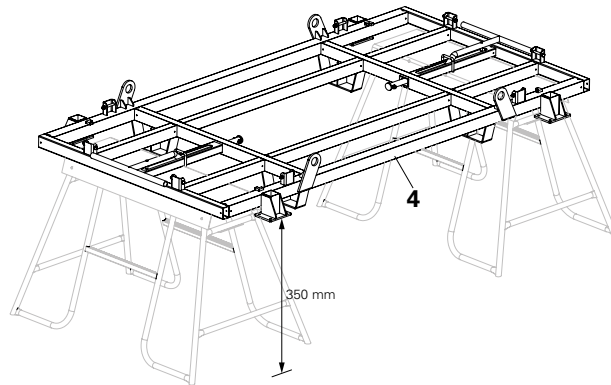

Fig. A1.02

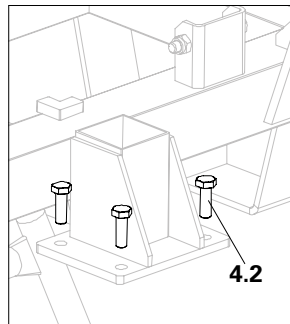

Fig. A1.02a

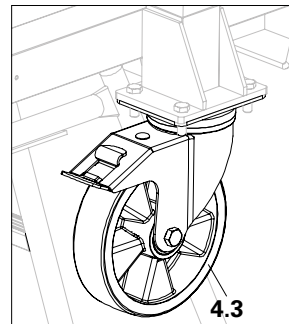

Fig. A1.02b

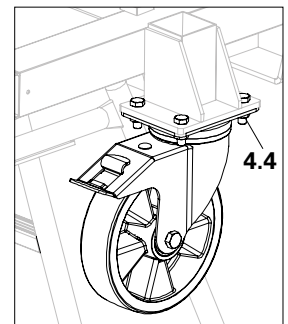

Fig. A1.02c

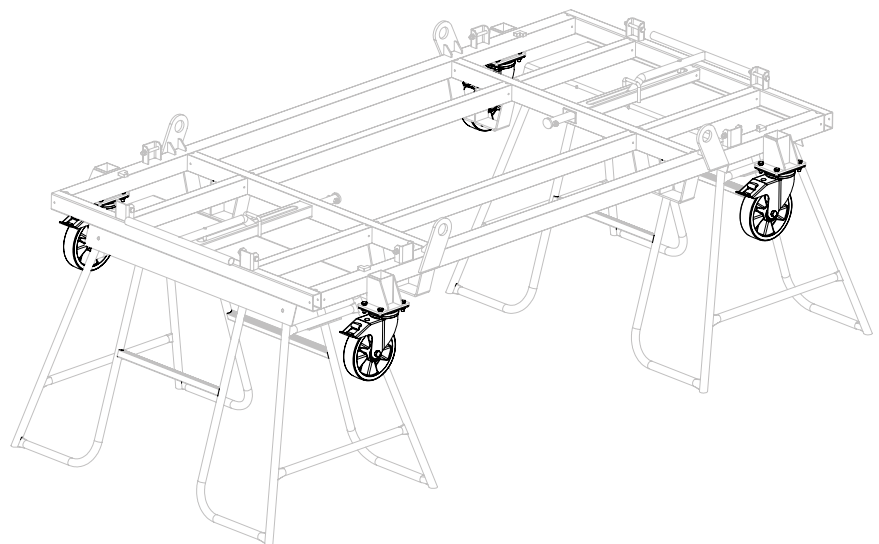

Fig. A1.03

Transporting the panels

The pallet AD (4) is designed with two integrated handles (4.5) and (4.6) that helps in easy transportation. (Fig. A1.04)



After the panels are stacked in the pallet, secure them properly with belt.

- 4 pc. 710594 belt spanner unit
L = 1400 mm
- 2 pc. 710595 belt lose end
L = 4200 mm
- 2 pc. 710596 belt lose end
L = 5000 mm

1. Pull the handle (4.5) and use it to move the pallet AD (4) manually to next location. The handle (4.6) is in docked condition. (Fig. A1.05)
2. Once reached at desired location, apply the brakes and put the handle (4.5) back to its position. (Fig. A1.06)



- Make sure that the brake is accessible when the pallet is loaded.
- Castor wheels must be removed, if two pallets are stacked over the other.

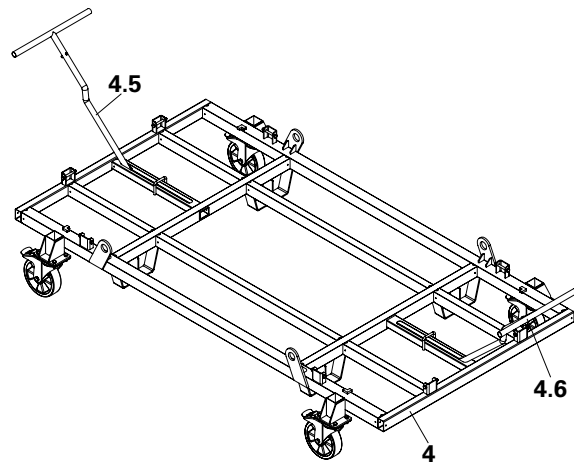

Fig. A1.04

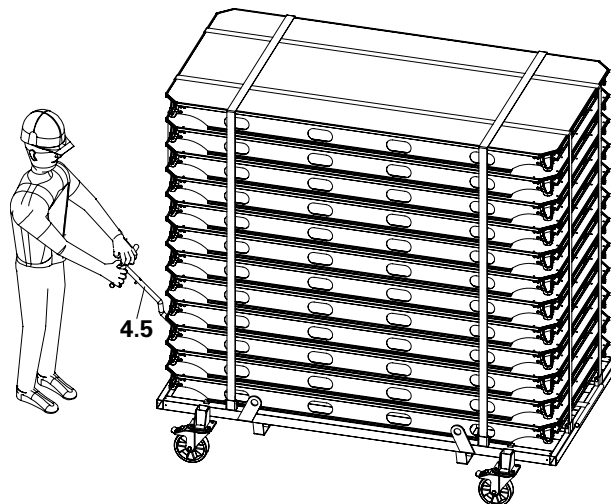

Fig. A1.05

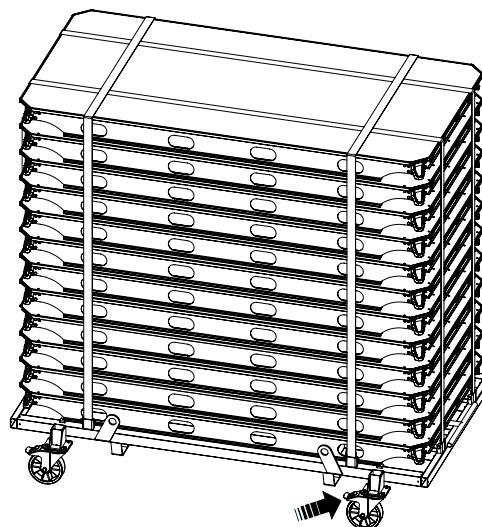

Fig. A1.06

Stacking aid AD

The stacking aid AD (**24**) is used for stacking the ALPHADECK panels in pallet AD or euro pallet.

It prevents the panels from sliding during transportation and protects formlining against damage.

Assembly using euro pallet

1. Install the stacking aid AD (**24**) through the edge rail A with approximate position of 40 - 45 cm from edge rail B.
2. Install the lashing straps (DIN EN 12195-2 standard) along the transverse direction below the euro pallet. (Fig. A1.08)
3. Install the other lashing straps along the longitudinal direction through the edge rail B.

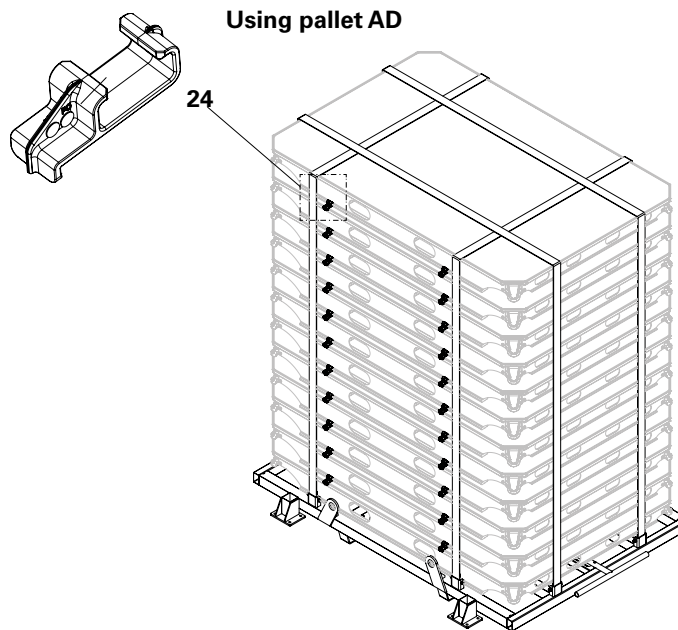

Fig. A1.07

Using euro pallet

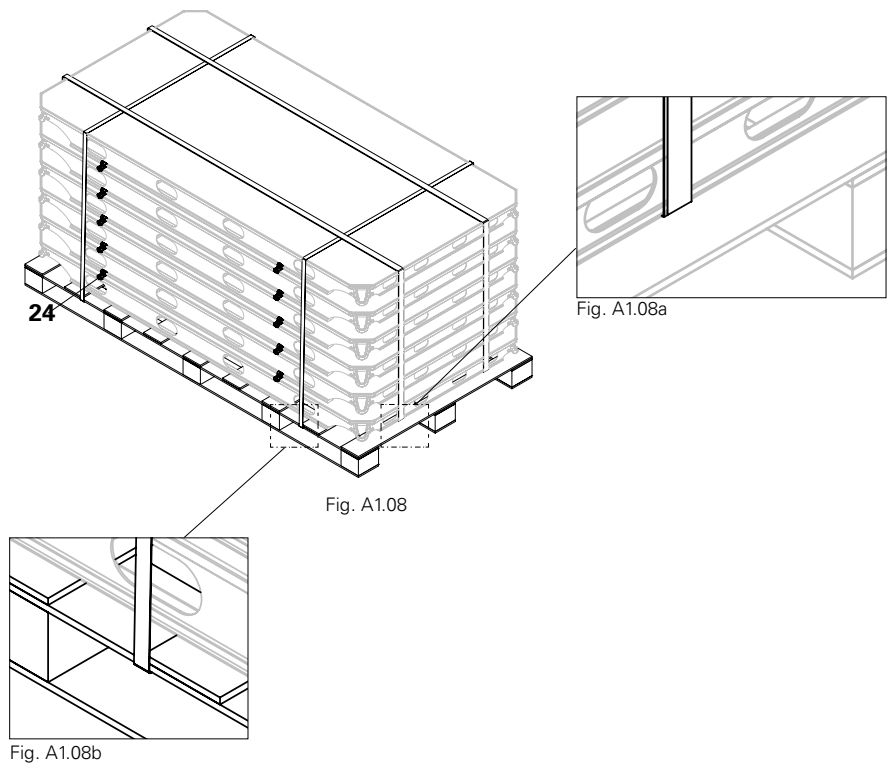
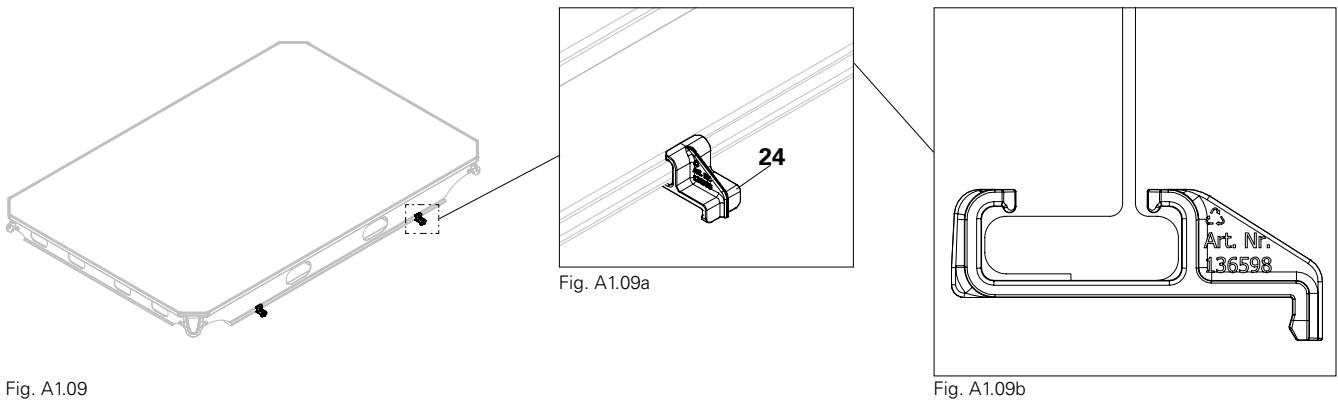

Fig. A1.08

Fig. A1.08a

Fig. A1.08b

Stacking aid AD on edge rail A



Approximate position of stacking aid AD from edge rail B

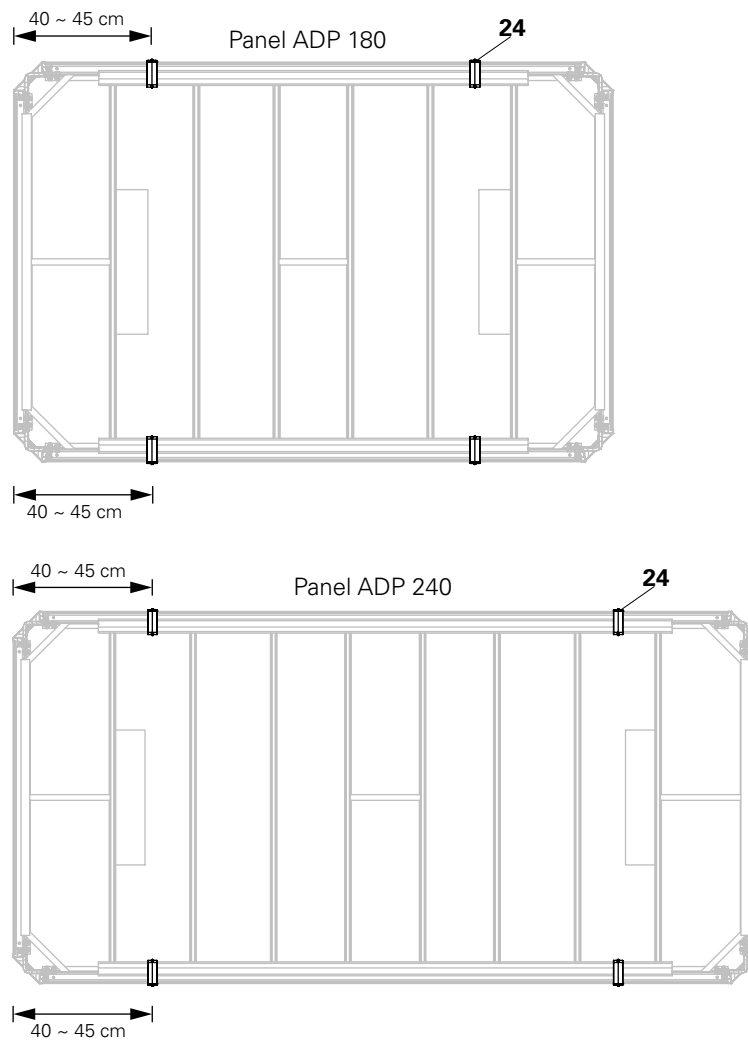

Fig. A1.10

Crate pallet 80 x 120

Load-bearing capacity = 1.5 t

Crane sling angle $\leq 15^\circ$

Stacking height: 3 crate pallets on top of each other

For better loading and unloading, the flap (5.1) can be pivoted downwards. (Fig. A1.12)

For securing the load against theft, the crate pallet (5) can be optionally fitted with a cover (art. no.: 065067).



Before transportation, close the flap and check that locking mechanism have properly engaged.

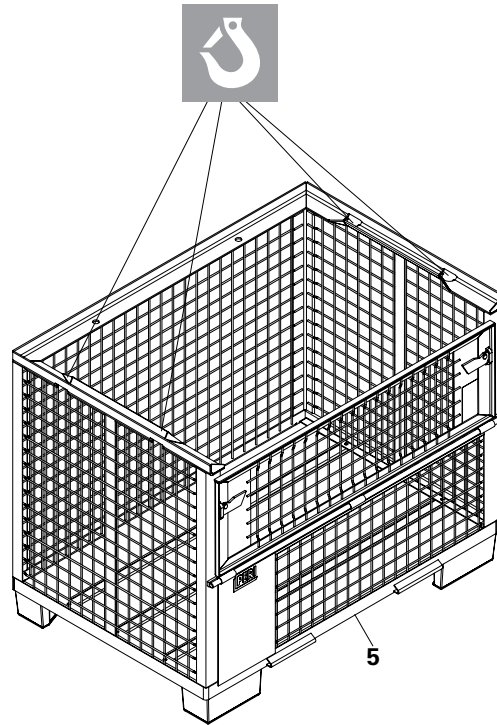

Fig. A1.11

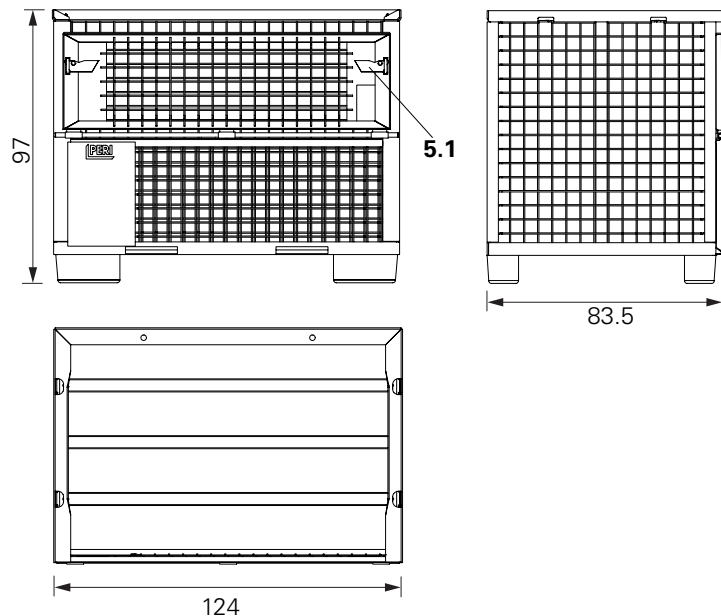

Fig. A1.12

Panel ADP

The panel ADP is available in two sizes:

- Panel ADP 240 x 120
- Panel ADP 180 x 120

The panel ADP frames are made of high strength and durable aluminum alloy which helps to keep the maximum panel weight below 50 kg.

The panel ADP (1) is powder-coated. It has have minimal contact area and undercut edges. (Fig. A2.03)
This minimizes the accumulation of slurry on the sides of the panels.

The formlining used is high performance film coated birch plywood of 9 mm thickness.

Components

-
- 1 Panel ADP
 - 1.1 Formlining
 - 1.2 Panel frame
 - 1.3 Edge rail A
 - 1.4 Edge rail B
 - 1.5 Cross strut C
 - 1.6 Stiffener
 - 1.7 Corner element
 - 1.8 Connecting hole for guardrail holder
 - 1.9 Connecting hole for anchor chain 3.0 kN
 - 1.10 Square tube
-



Fig. A2.01

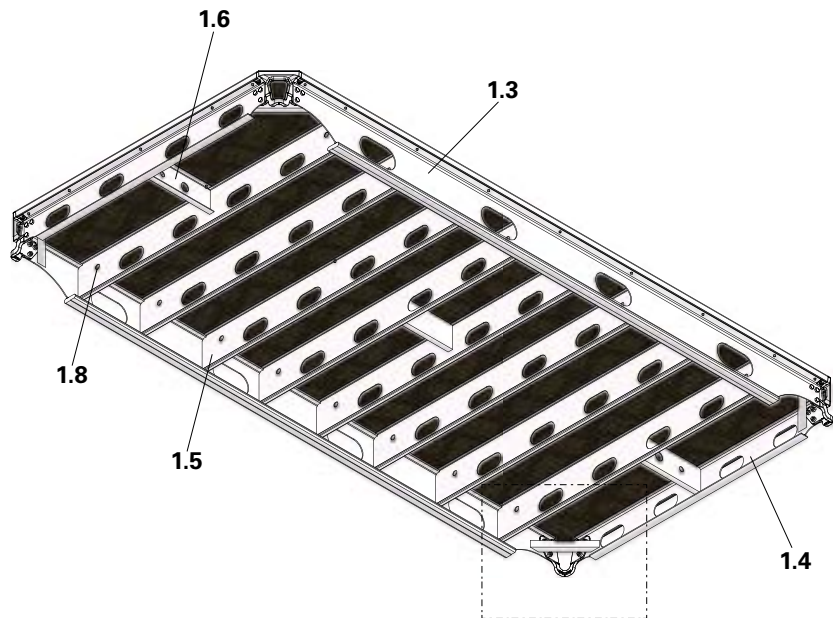

Fig. A2.02

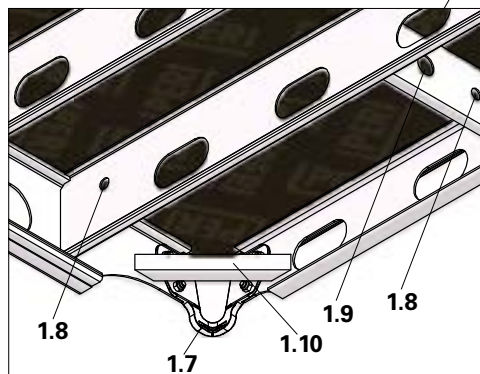

Fig. A2.02a

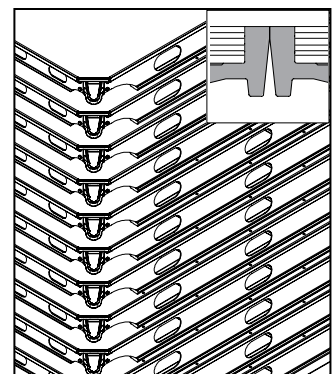

Fig. A2.03

Drophead ADH

The drophead ADH (2) allows early striking and easier deshuttering of panels.

Only one type of head serves all requirements.

The drophead is released with the help of a hammer, which causes the panel to drop by 12 cm.

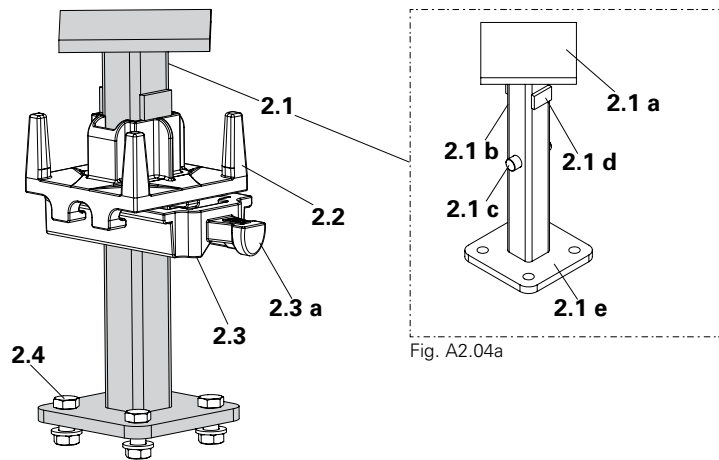

Fig. A2.04

Components

- 2** Drophead ADH
- 2.1** Vertical stem
- 2.1a** Top plate
- 2.1b** Tube
- 2.1c** Loading pin
- 2.1d** Stopper
- 2.1e** Bottom plate
- 2.2** Flyplate
- 2.3** Wedge
- 2.3a** Nose
- 2.4** M12 bolt, nut and washer

Slab props

PERI PEP ERGO, PEP Alpha and PEP Alpha-2 are recommended for slab formwork with ALPHADECK system.



- Take into account the permissible prop loads of the slab props, see Section "B1 Load charts for slab props" on page 74.
- Maximum permissible slab thickness is 35 cm for the panel ADP 240 x 120 and 55 cm for the panel ADP 180 x 120.

Preparing the slab props

- The exact extension length of the prop when using the ALPHADECK drophead is:
Prop height = Clear room height minus 31.5 cm
- Please use suitable prop so that the permissible prop load is more than actual prop loads.
- Use M12 bolt (2.4 a), nut (2.4 b) and washer (2.4 c) to attach the prop (3) to the drophead (2). (Fig. A2.05)

Required components

- 2 Drophead ADH
- 2.4a M12 bolt
- 2.4b Nut
- 2.4c Washer
- 3 Prop



Always use M12 bolt on the drophead (2) side and nut on the prop (3) side. (Fig. A2.05a)



Warning

Risk of collapse!

A fall can result in serious injuries or even death!

⇒ Always use four M12 bolts (2.4 a), four nuts (2.4 b) and four washers (2.4 c) while fixing drophead to the prop. (Fig. A2.05c)

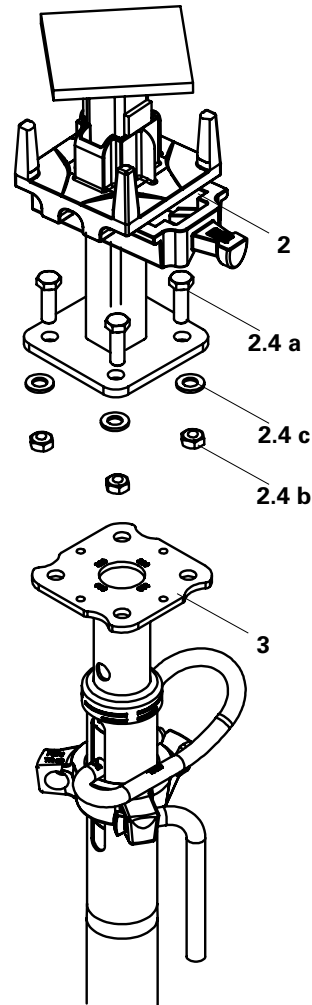

Fig. A2.05

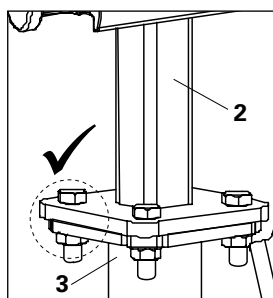

Fig. A2.05a

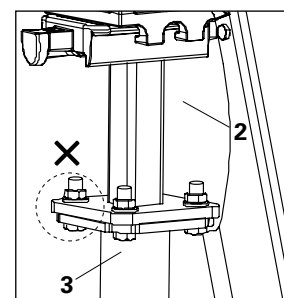

Fig. A2.05b

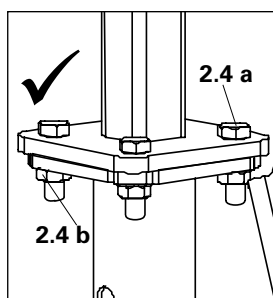

Fig. A2.05c

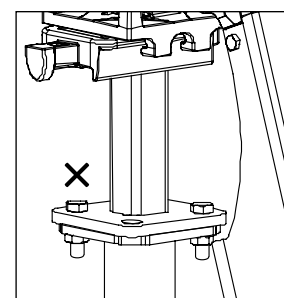

Fig. A2.05d

Brace ADB

Brace ADB (7) provides temporary stability for the ALPHADECK system during its erection. (Fig. A2.06)

Brace ADB (7) are available in three sizes: ADB 240, ADB 180 and ADB 120

Components

- 7 Brace ADB
- 7.1 PRK head
- 7.2 Bracing frame
- 7.3 M12 x 70 Bolt and nut



- Brace ADB (7) can be used with prop of outer diameter above 57 mm.
- If props are below 57 mm diameter, then timber with brace clamps can be used for bracing. (Fig. A2.07)
- Mount diagonal bracing as assembly aid with boards and brace clamps.

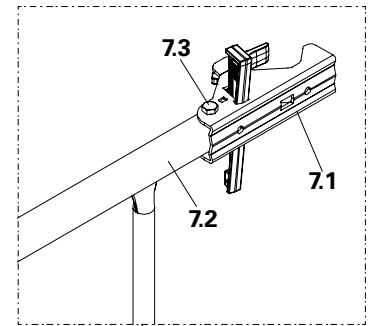

Fig. A2.06a

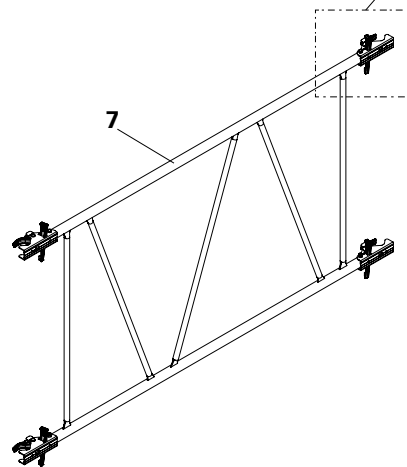

Fig. A2.06

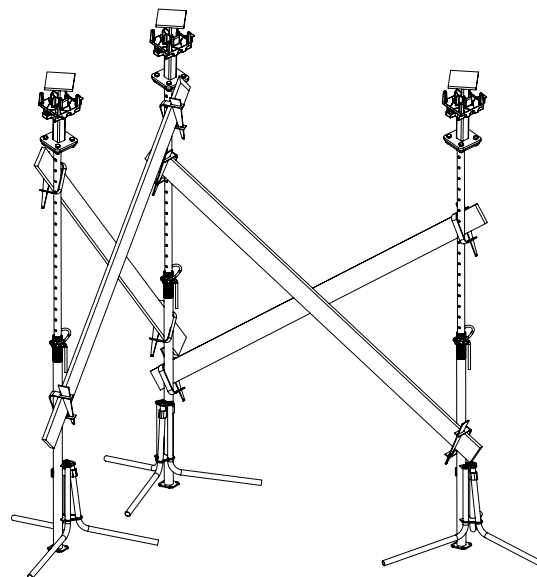

Fig. A2.07

Shuttering aid AD

The shuttering aid AD (**6**) is used to assemble and dismantle the panel ADP.

The length is adjustable from 2.5 m to 4.3 m with 10 cm intervals.



Warning

The shuttering aid can slip sideways, e.g. through an impact, and thus cause the component being held to collapse.

⇒ Always ensure that the shuttering aid is secured by a member of the construction team.



- Length adjustments are to be carried out only in an unloaded state.
- Always insert the linch pin (**6.1**) through both holes of the inner (**6.3**) and outer (**6.2**) tubes.
- The inner tube (**6.3**) should not be resting on top of the linch pin (**6.1**).
- Secure the linch pin (**6.1**).
(Fig. A2.08a)

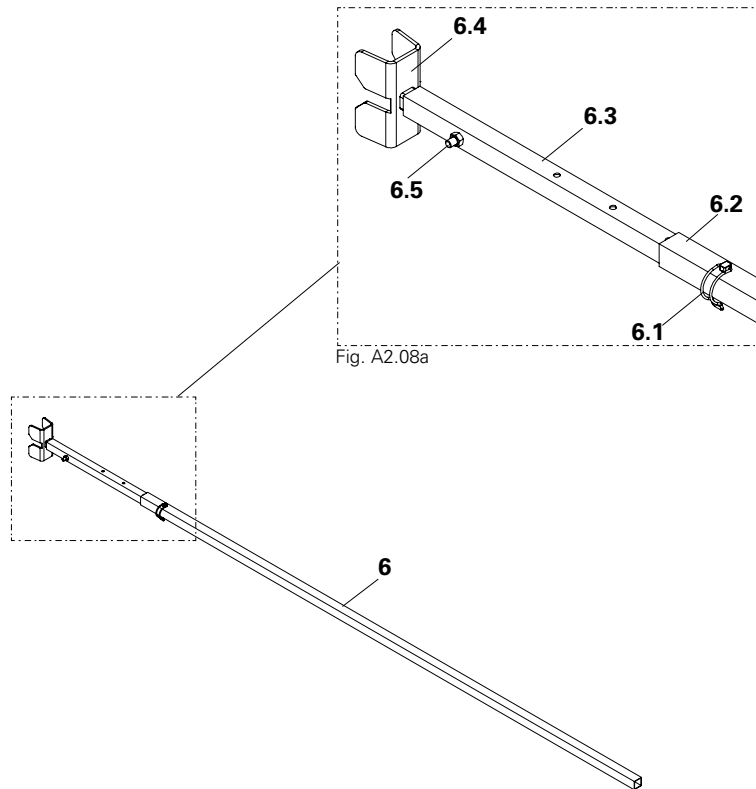

Fig. A2.08

Components

- 6** Shuttering aid AD
- 6.1** Linch pin
- 6.2** Outer tube
- 6.3** Inner tube
- 6.4** Head
- 6.5** M10 x 50 bolt and nut

Filler beam ADF

Infill areas can be closed with the filler beam ADF (8) and cut to suit plywood. (Fig. A2.09)

Filler beam ADF are available in three sizes: ADF 240, ADF 180 and ADF 120.

The same filler beam is compatible for plywood thickness (t) ranging from 12 mm to 18 mm by varying the timber insert (8.3) size. (Fig. A2.09a)

- d = depth of timber insert
- t = plywood thickness
- w = width of timber insert

Use torx screw 6 x 40 mm (8.1) article no. 024540 to secure the timber insert (8.3) with 12 mm packing (8.2) at every 60 cm center to center. (Fig. A2.09a)

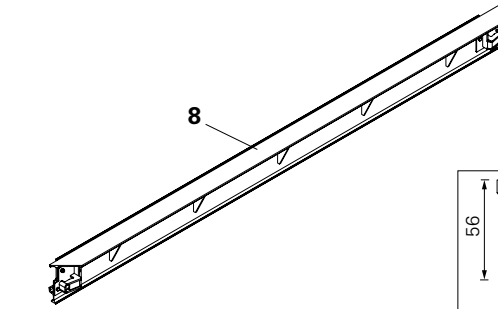

Fig. A2.09

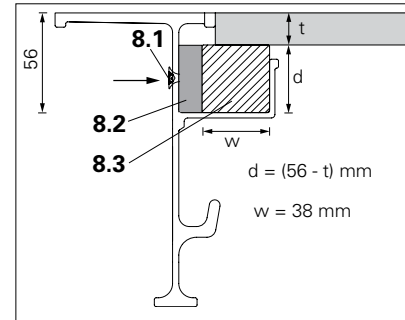

Fig. A2.09a

Filler beam ADF with ADF-P nailing insert

Filler beam ADF with ADF-P nailing insert are available in three sizes: ADF-P 240, ADF-P 180 and ADF-P 120.

They are only compatible for 18 mm plywood thickness.

Length of ADF-P Nailing Insert (27):

- 56 cm for ADF-P 240 and ADF-P 180
- 53 cm for ADF-P 120

Assembly

1. Install the ADF-P nailing insert (27) into the slot of filler beam ADF (8)
- See (Tab. A2.01) for the no. of inserts into respective beam sizes.

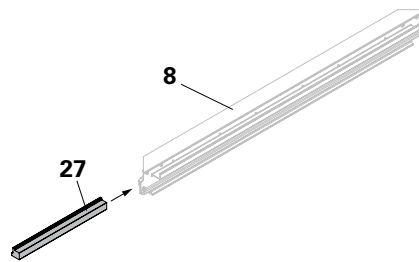

Fig. A2.10

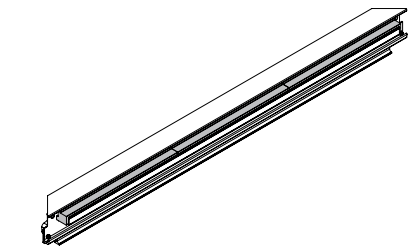

Fig. A2.11

Filler beam sizes	Length of insert (L)	No. of inserts	No. of screws
ADF-P 240	56 cm	4	8
ADF-P 180	56 cm	3	6
ADF-P 120	53 cm	2	4

Tab. A2.01

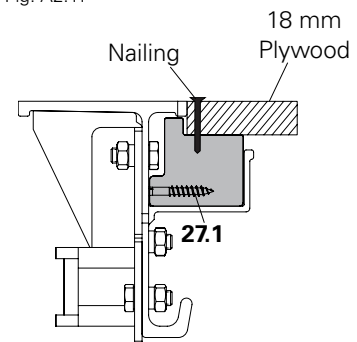

Fig. A2.12

2. Use torx screw 6 x 40 mm **(27.1)** (article no. 024540) to secure the ADF-P nailing insert **(27)** with filler beam ADF **(8)**. See (Tab. A2.01) for the no. of torx screws and (Fig. A2.13) for 7 mm dia hole location.

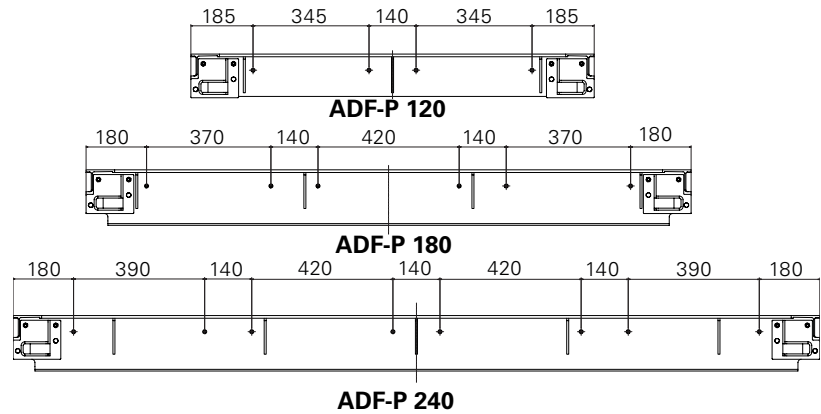

Fig. A2.13

Guardrail holder ADG with guardrail post HSGP-2

The guardrail holder ADG **(9)** with guardrail post HSGP-2 **(10)** secures site personnel working on a casting segment against falling in both directions. (Fig. A2.14 + Fig. A2.15)

The system consists of guardrail holder ADG **(9)** and guardrail post HSGP-2 **(10)**.

Components

- 9** Guardrail holder ADG
- 10** Guardrail post HSGP-2

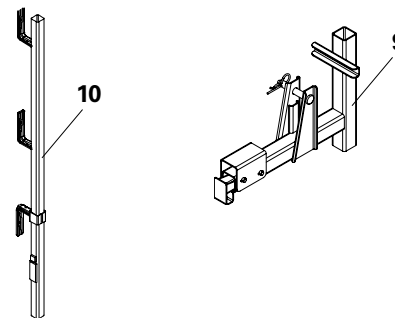

Fig. A2.14

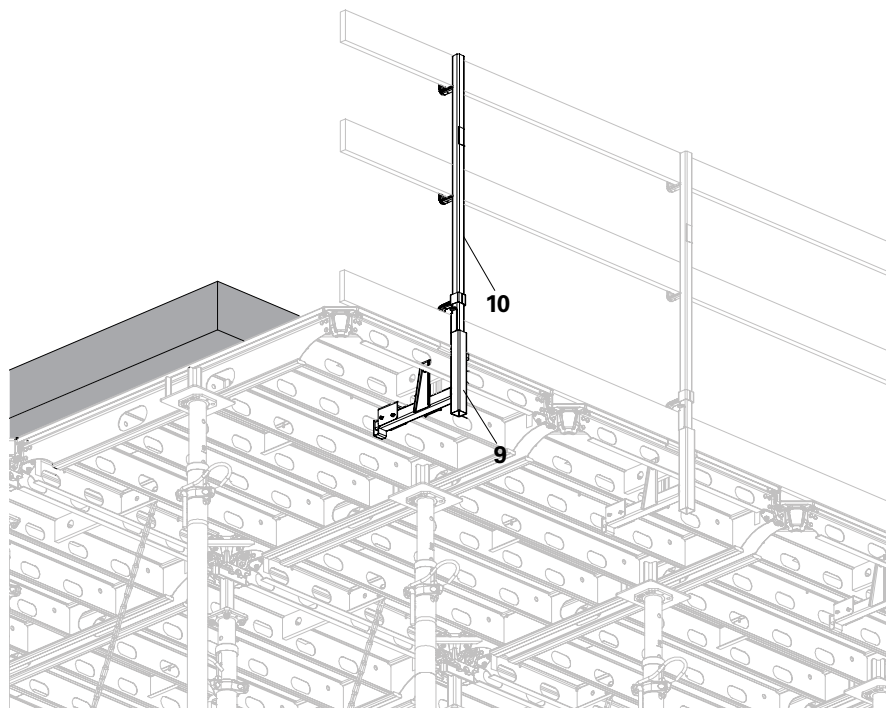

Fig. A2.15

Corner insert AD

The corner insert AD (**25**) is an add-on component in the ALPHADECK system.

It is made out of polymer and is used to convert a chamfered corner of ALPHADECK corner into a right-angle corner.

It can be used to start the shuttering of ADP panels from the wall end without the use of a filler beam.

The change of direction is also possible in the ALPHADECK system by using the corner insert AD.

Assembly

1. Install the corner insert AD (**25**) through the corner element (**1.7**) of the panel (**1**). (Fig. A2.18)
2. Ensure that the triangular clip (**25.1**) is locked on the square-tube (**1.10**) of the panel (**1**). (Fig. A2.19)
3. The corner insert AD (**25**) is now secured in locked position. (Fig. A2.20)

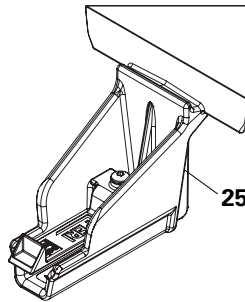

Fig. A2.16

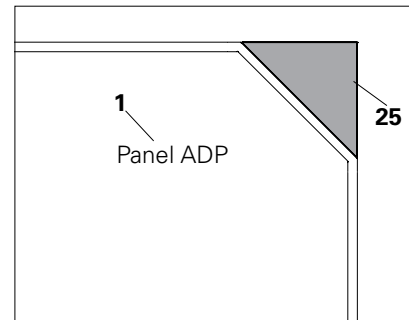

Fig. A2.17

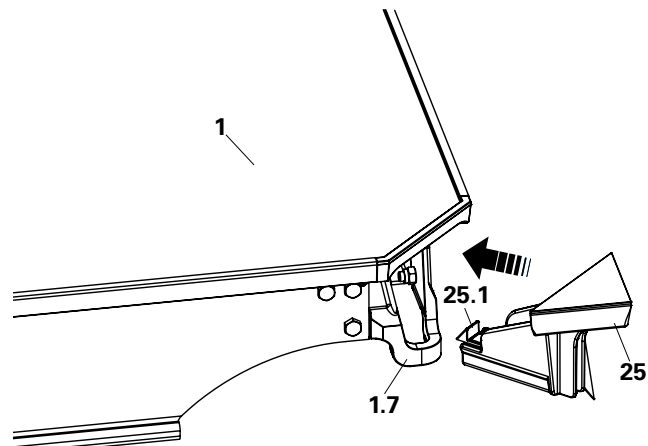

Fig. A2.18

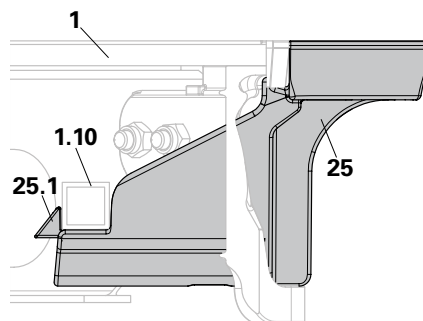

Fig. A2.19

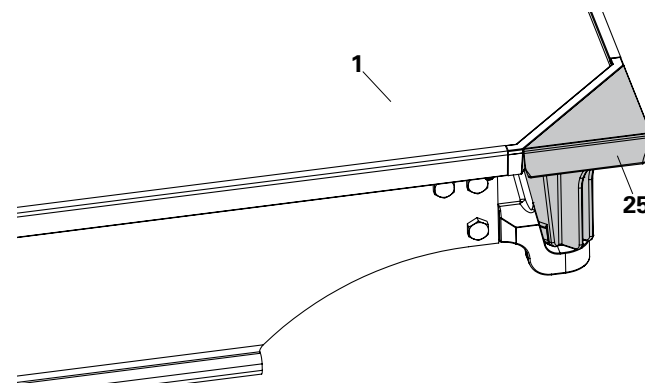

Fig. A2.20

Disassembly

1. To remove the corner insert AD (25) from the panel, press-down the triangular clip (25.1) and release the locking from square tube (1.10) of the panel (1). (Fig. A2.21 + Fig. A2.22)
2. Remove the corner insert AD (25) from the corner element (1.7) of the panel (1). (Fig. A2.23)

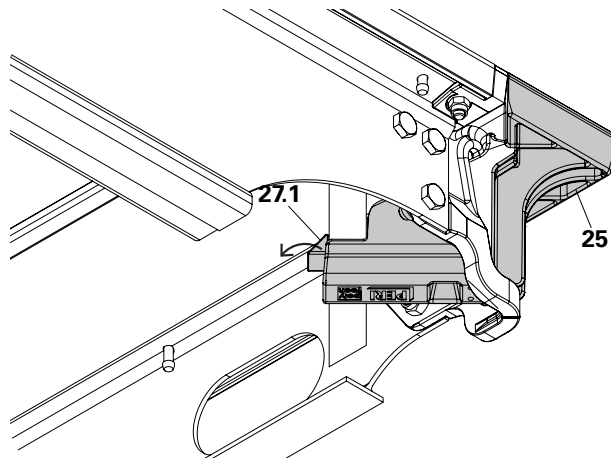

Fig. A2.21

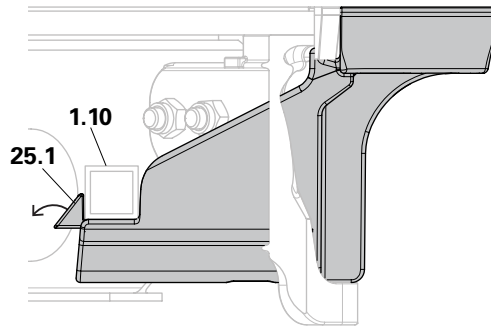

Fig. A2.22

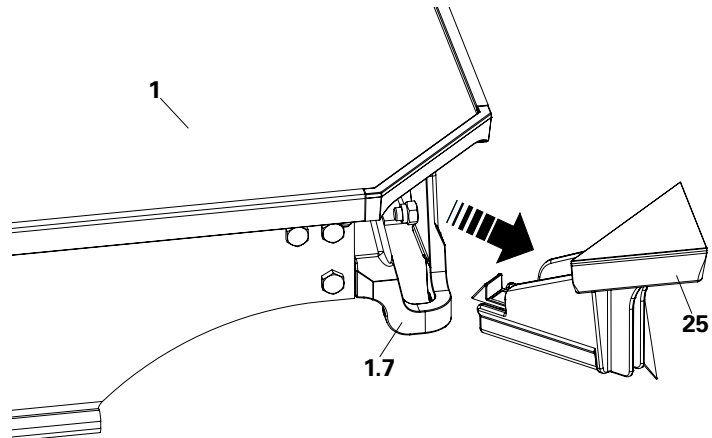

Fig. A2.23

Notes for static calculations

This design information is used for the design and planning of the ALPHADECK Slab Formwork System. It covers standard configurations for slab thickness of 35 cm for the panel ADP 240 x 120 and 55 cm for panel ADP 180 x 120.

Comparison of the design methods

The design concept with partial safety factors

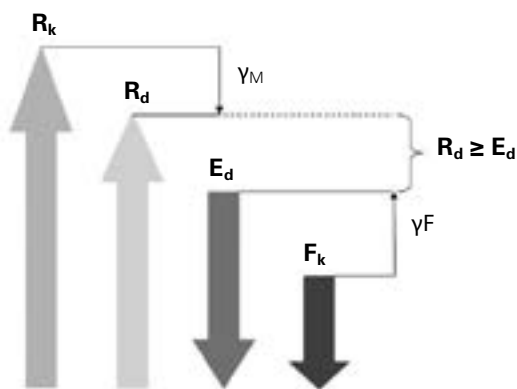

Method of proof

$$\frac{R_k}{\gamma_M} \geq F_k \cdot \gamma_F$$

$$R_d \geq E_d$$

The old design concept with the absolute safety factor (see PERI Design Tables)

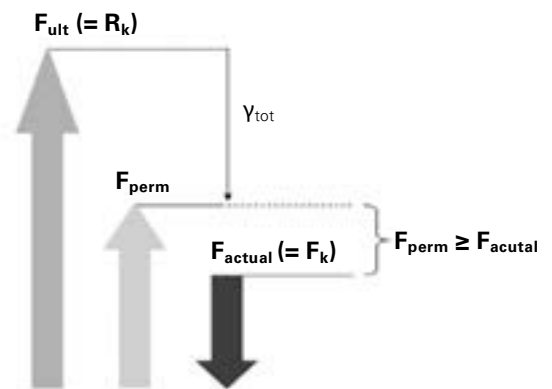

Method of proof

$$\frac{F_{ult}}{\gamma_{tot}} \geq F_{actual} (= F_k)$$

$$F_{perm} \geq F_{actual} (= F_k)$$

Key

- R_k = characteristic resistance
- R_d = design value of the resistance
- F_k = F_{actual} = actual or characteristic action
- E_d = design value of the action
- F_{ult} = R_k = characteristic resistance (e.g. breaking load)
- F_{perm} = Permissible load-bearing capacity

- γ_M = partial safety factor for the material (steel ≈ 1.1 / concrete ≈ 1.5)
- γ_F = partial safety factor for the load (permanent = 1.35 / changeable = 1.5)
- $\gamma_{tot.}$ = absolute safety factor $\approx \gamma_M \cdot \gamma_F$ (steel ≈ 1.65 / concrete ≈ 2.25)

Design method used in this design information

This design information is based on the design concept with the absolute safety factor.

The tables of the prop loads include the permissible load-bearing capacities $F_{perm.}$

After multiplication using $\gamma_F = 1.5$, the maximum load-bearing capacity can also be converted into a design value of the resistance R_d for the method with partial safety factors.

Prop loads in panel system

Slab thickness d [mm]	Total Load q** [kN/m ²]	Prop load [kN]	Deflection to DIN 18202, Line	Panel ADP 180 x 120	
				Panel ADP 240 x 120	Panel ADP 180 x 120
100	4.2	12.1	7	9.1	7
125	4.9	14.2	7	10.6	7
150	5.5	15.9	7	11.9	7
175	6.1	17.6	7	13.2	7
200	6.7	19.3	7	14.5	7
225	7.4	21.4	7	16.0	7
250	8.0	23.1	6	17.3	7
275	8.6	24.8	6	18.6	7
300	9.2	26.5	6	19.9	7
325	9.9	28.6	6	21.4	7
350	10.6	30.6	6	22.9	7
375	11.3	-	-	24.5	7
400	12.0	-	-	26.0	7
425	12.7	-	-	27.5	7
450	13.4	-	-	29.0	6
475	14.1	-	-	30.5	6
500	14.7	-	-	31.8	6
525	15.4	-	-	33.3	6
550	16.1	-	-	34.8	6

Tab. A3.01

Calculation basis:

**Load according to EN 12812

$$\text{Dead load } Q_1 = 0.20 \text{ kN/m}^2$$

$$\text{Concrete load } Q_{2,b} = 25 \text{ kN/m}^3 \times d \text{ [m]}$$

$$\text{Equivalent load concreting } Q_4 = 0.10 \times Q_{2,b}$$

$$0.75 \text{ kN/m}^2 \leq Q_4 \leq 1.75 \text{ kN/m}^2$$

$$\text{Equivalent load working conditions } Q_{2,p} = 0.75 \text{ kN/m}^2$$

$$\text{Total load } Q = Q_1 + Q_{2,b} + Q_{2,p} + Q_4$$

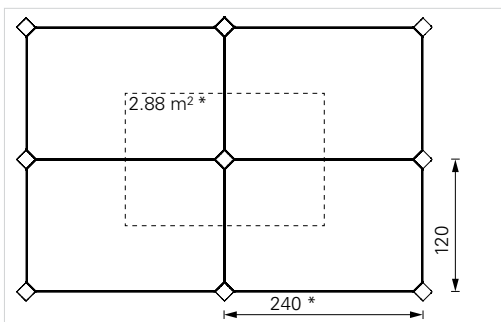

*For ADP 180,
influence area of prop = 2.16 m²



- Please use suitable prop so that the actual prop load given in (Tab. A3.01) is less than the permissible prop loads shown, see Section "B1 Load charts for slab props" on page 74.
- **When calculating the perm. prop loads, the extension length of the prop should be considered up to top of the flyplate**
Extension length = clear room height - 12 cm.
For actual prop length required for slab preparation, see Section "Preparing the slab props" on page 22.
- When using the anchor chain 3.0 kN, increase the prop loads for the braced panels considering 2.6 kN per chain.
- If anchor chain 3.0 kN is used in the system, consider deflection according to DIN 18202 Line 6 for all slab thickness.
- Deflection is according to DIN 18202 assuming perfect levelling.

Example for calculation of perm. prop load

Floor to floor height	= 4.0 m
Slab thickness	= 25 cm
Clear room height (4.00 m - 0.25 m)	= 3.75 m
Extension length (clear room height - 12 cm = 3.75 m - 0.12 m)	= 3.63 m ~ 3.7 m
Max. panel size	= ADP 240 x 120
Actual prop load (Refer to Table A3.01)	= 23.1 kN
Selected prop	= PEP Ergo D400
Direction of assembly	Inner bottom <input type="checkbox"/> Outer bottom <input checked="" type="checkbox"/>
Perm. prop load (according to PERI Tables - refer to Table A3.02)	= 27 kN
Actual prop load ≤ Perm. prop load	OK <input checked="" type="checkbox"/> Not OK <input type="checkbox"/>
Hence, SAFE	

Extract of load chart for slab prop

Extension length [m]	PEP Ergo D-400	
	Outer tube bottom	Inner tube bottom
3.50	31.0	39.7
3.60	29.0	36.4
3.70	27.0	33.3
3.80	25.2	30.7
3.90	23.5	28.2

Tab. A3.02

General



Warning

- During assembly, components could fall out, strike personnel and seriously injure them as a result of carelessness or maloperation!
 - ⇒ Do not remain in the areas of risk for no good reason.
 - ⇒ Wear a safety helmet.
 - ⇒ Wear safety shoes.
 - ⇒ Wear safety gloves.
- When wind speeds reach 28 km/h and more, panels can lift off and the slab formwork can collapse! Falling components can strike personnel and seriously injure them. To avoid such an incident:
 - ⇒ Apply ballast to the slab formwork.
 - ⇒ Dismantle the formwork for unfavourable structure geometries.



- Plan slab formwork carefully. When planning the layout, take building columns, projections and recesses and other filler areas into account.
- It is not mandatory to start the system from wall corner. The system can be erected using bracings from anywhere in between. But if required, start at a corner of the room as per the layout.
- Position the slab props in such a way that it is possible to handle the G-hooks and keep them secured.
- Allow for a striking clearance of 2.5 cm at the props.



- For working areas with shuttering height 3 m and above, choose a safe working area, e.g. mobile scaffolds.
- Shuttering from above wherever required to be done is permitted only with PPE.

Starting bay

1. Extend the props (**3**) to required working height, see Section "Preparing the slab props" on page 22.
2. Erect three props at the starting corner (L-shaped). (Fig. A4.01)



To facilitate easy striking, ensure that the direction of wedge (**2.3**) is parallel to the width of the panel with its nose facing inwards i.e. opposite to the direction of assembly. (Fig. A4.01a)

3. Attach the brace ADB (**7**) to the props (**3**).
4. To lock the brace ADB (**7**), strike the wedge (**7.1**) by hammer. (Fig. A4.01b) Make sure that the wedge is properly locked to the props to ensure stability.



When installing the brace ADB (**7**), ensure that the bottom wedge of PRK head (**7.1**) has enough clearance of 30 cm from the ground for easy removal. (Fig. A4.01b)

5. Hang the panel ADP (**1**) into the two props. (Fig. A4.02)



Make sure that the panel corners are properly hooked onto the drophead ADH (**2**) flyplate pin. (Fig. A4.02a)

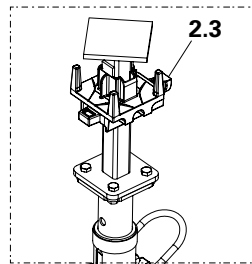

Fig. A4.01a

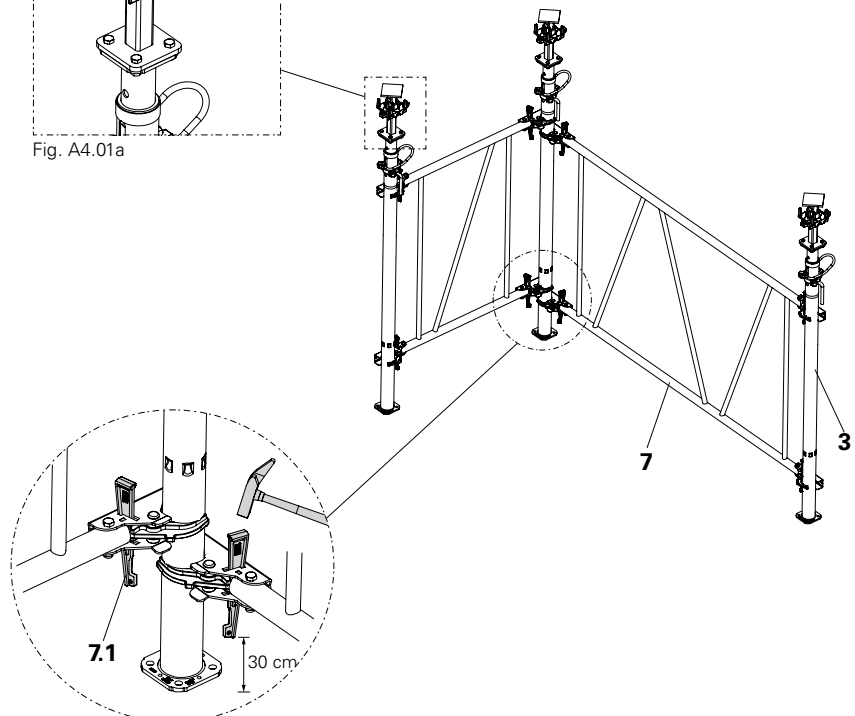

Fig. A4.01b

Fig. A4.01

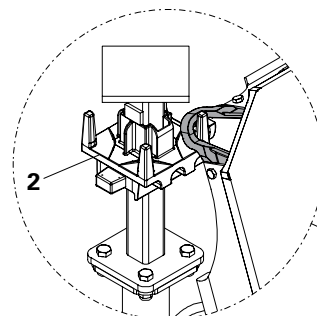

Fig. A4.02a

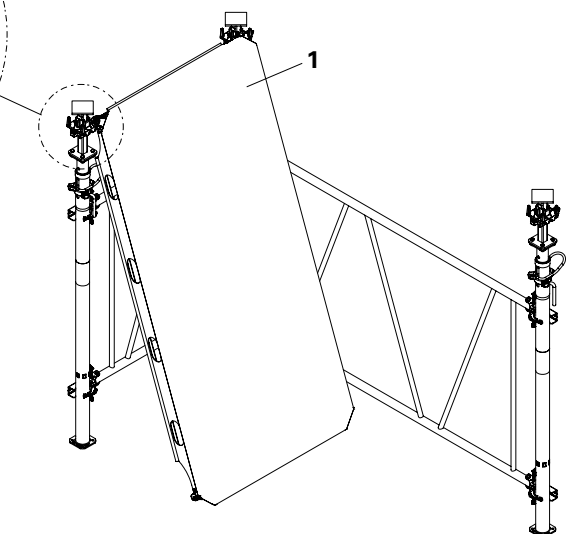

Fig. A4.02

6. Swing the panel ADP (1) upwards with the shuttering aid (6) and hook on the third prop (3). (Fig. A4.03)



- Ensure that the shuttering aid (6) is supporting the panel edge in the middle to avoid tilting. (Fig. A4.03a)
- 7. Secure with shuttering aid (6) temporarily until the prop is brought into support position. Fig. A4.04a
- 8. While the shuttering aid is supporting, attach the fourth prop (3) to the panel corner. (Fig. A4.04)
- 9. Install the brace ADB 120 (7) to the fourth prop (3). (Fig. A4.05)
- The starting bay is complete.

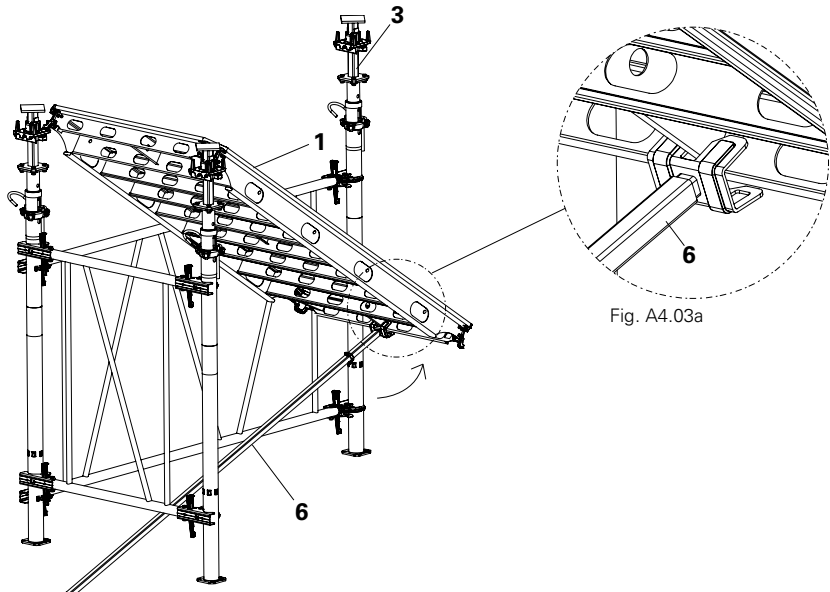

Fig. A4.03

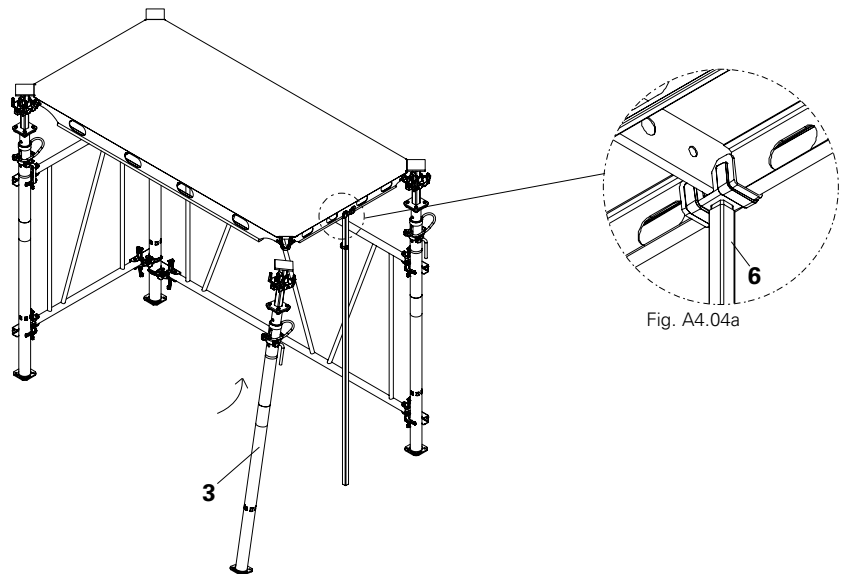

Fig. A4.04

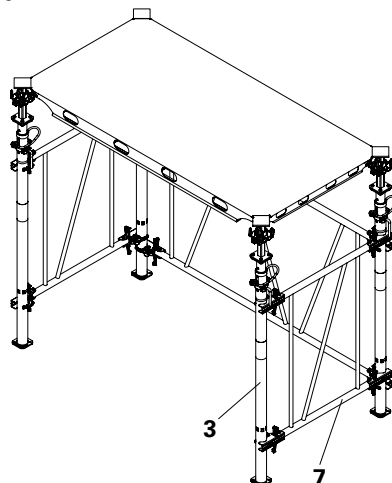

Fig. A4.05

Shorter direction

1. To continue erection in shorter direction, assemble the adjacent panel in the same way.
2. Using the shuttering aid (6), swing the panel up supporting it temporarily until the next two props are installed. (Fig. A4.06)



Ensure that the shuttering aid (6) is supporting the panel edge in the middle to avoid tilting.

3. Attach the next two props to the panel corners in the same manner. (Fig. A4.07)



Ensure that the direction of wedge is parallel to the width of the panel with its nose facing inwards. (Fig. A4.07a)

4. Repeat the process until the first row of the panels have been erected in shorter direction.

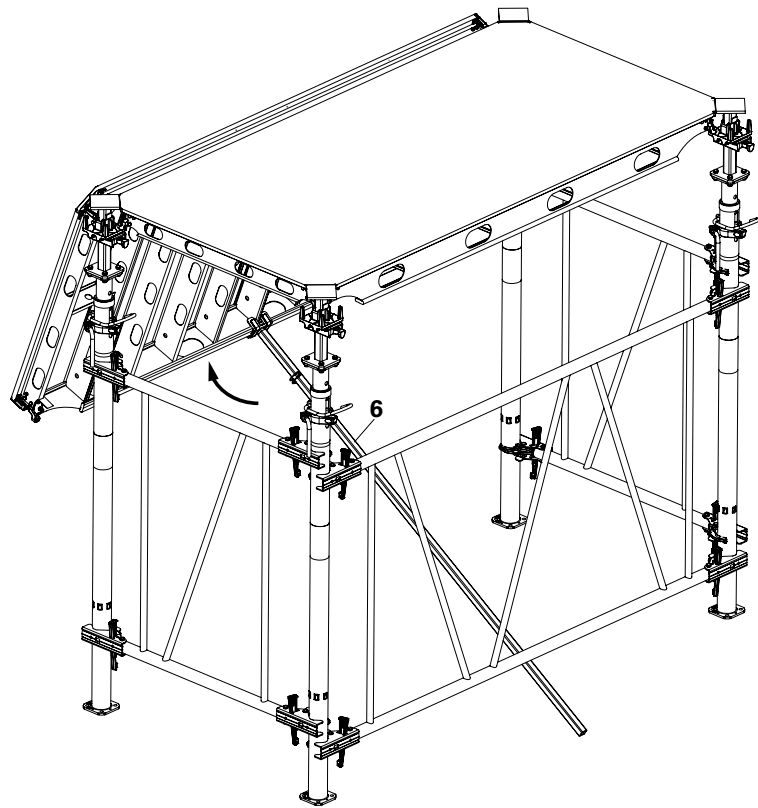

Fig. A4.06

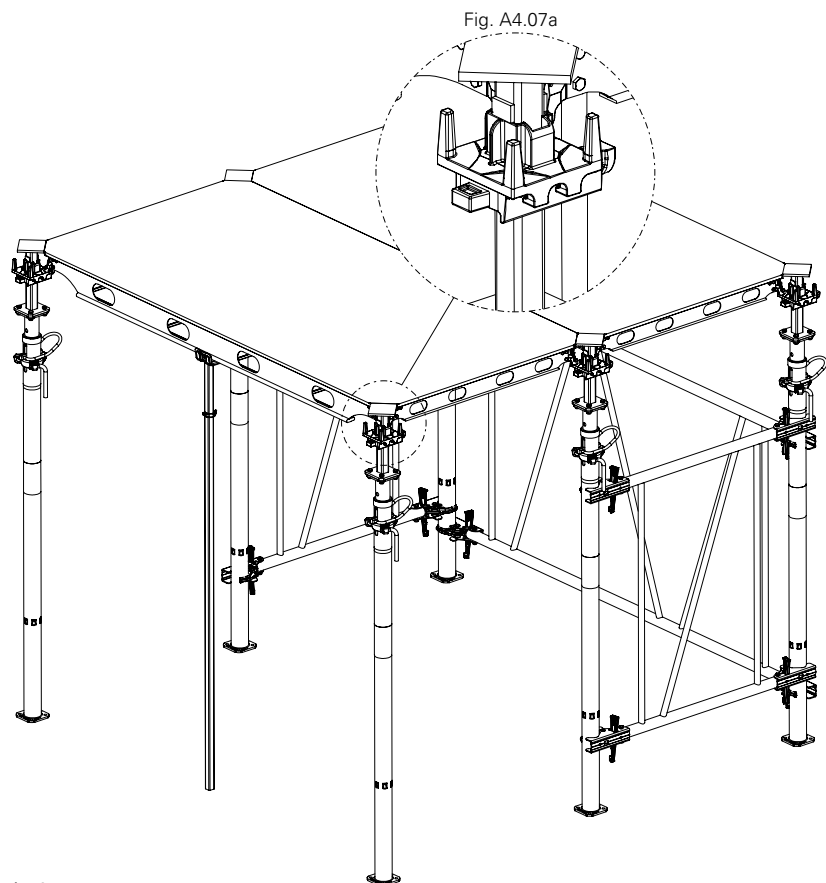

Fig. A4.07

The assembly can be continued simultaneously in any direction.

Longer direction

1. Hang the next panel (1) into the props as done in shorter direction.
2. Using the shuttering aid (6), swing the panel (1) up supporting it temporarily until the next two props are installed. (Fig. A4.08)
3. While keeping the shuttering aid (6) as a temporary support, attach the next prop (3) to the third corner of the panel (1). (Fig. A4.09)
4. Hook and swing the next panel (as shown in step 1 and 2) using an additional shuttering aid (6a). (Fig. A4.10)

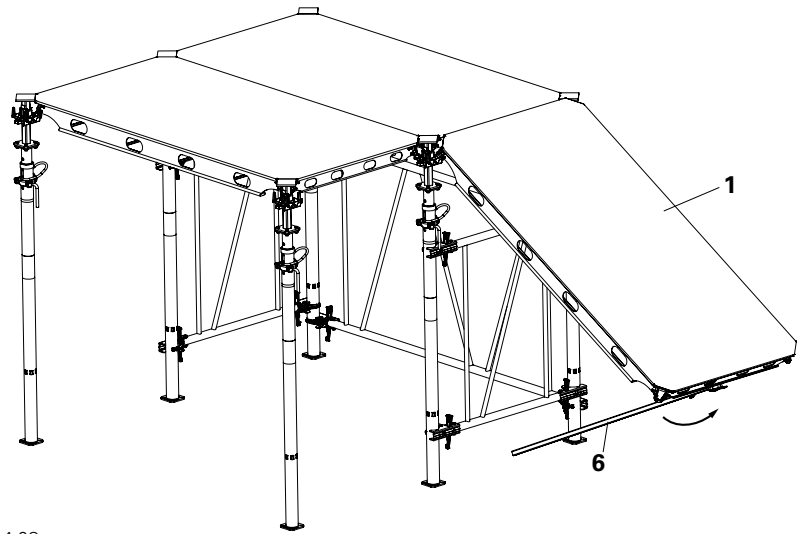

Fig. A4.08

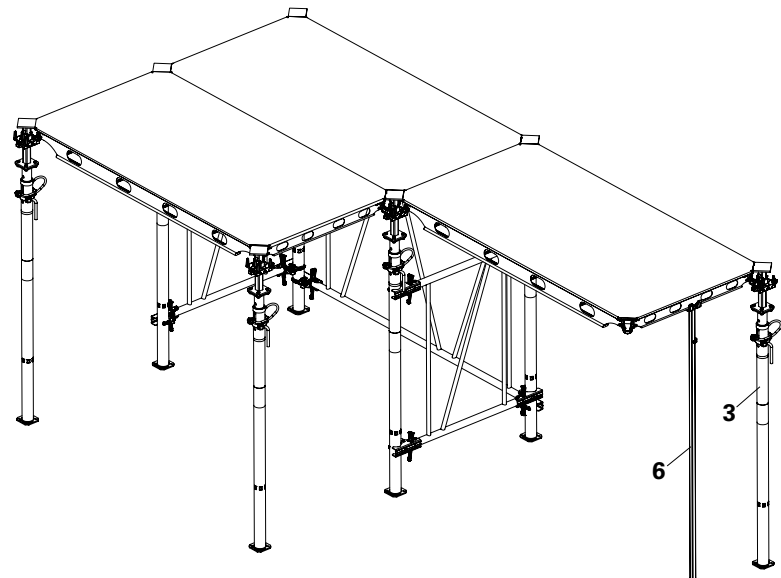

Fig. A4.09

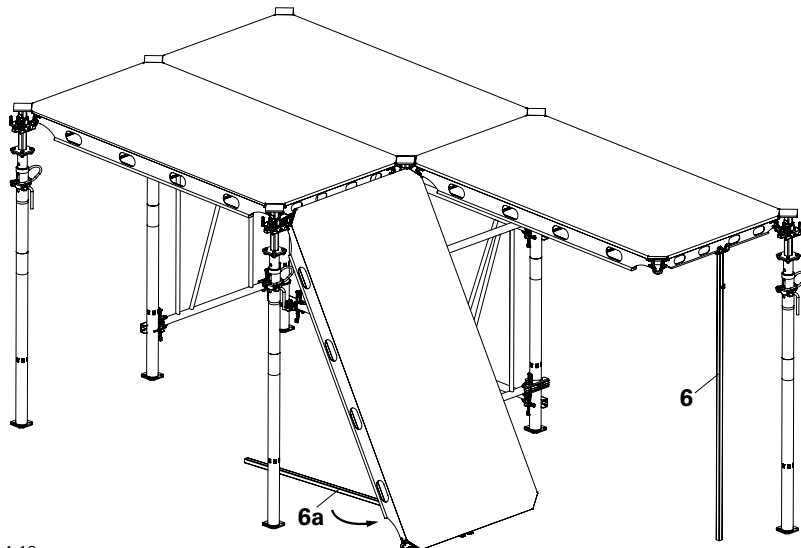

Fig. A4.10

5. Now, both the shuttering aids (**6**) and (**6a**) act as temporary support until the next prop is attached to the panel corner. (Fig. A4.11)



Ensure that the shuttering aid is supporting the panel edge in the middle to avoid tilting.

6. Insert the prop (**3**) into position with the wedge oriented in shorter direction for easy deshuttering. (Fig. A4.12)

7. Once the prop is set into position, the first shuttering aid (**6**) can be removed while the second shuttering aid supports the panel further. (Fig. A4.13)

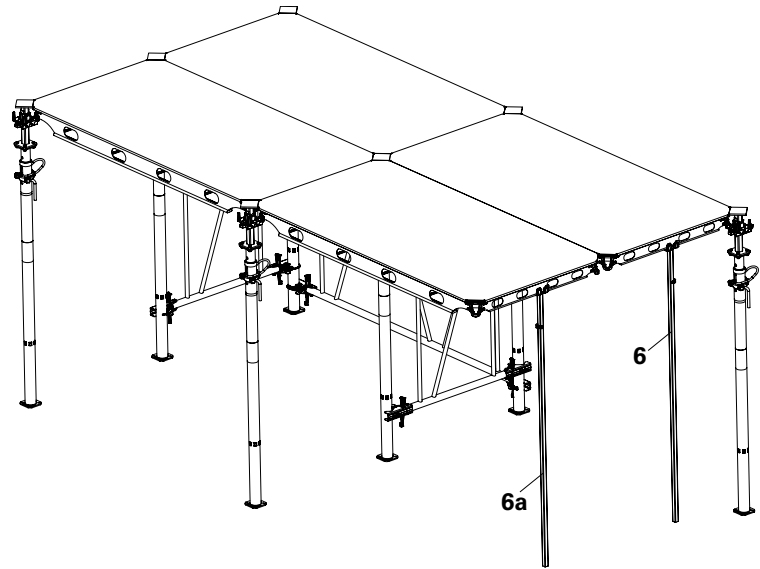

Fig. A4.11

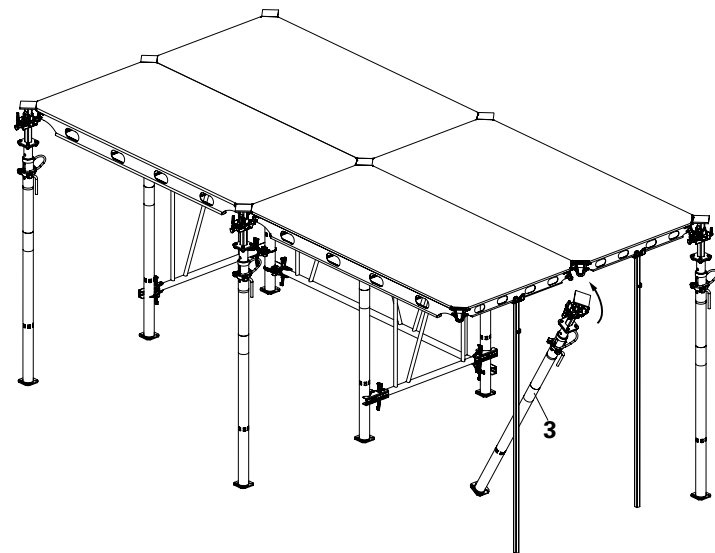

Fig. A4.12

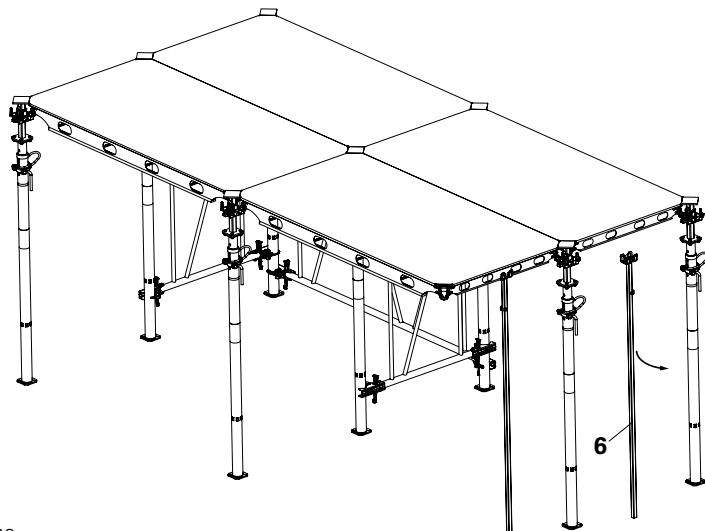

Fig. A4.13

8. Repeat the process until the shuttering is completed in both the directions.
9. Once the last prop is set into position, remove the second shuttering aid (**6a**). (Fig. A4.14)

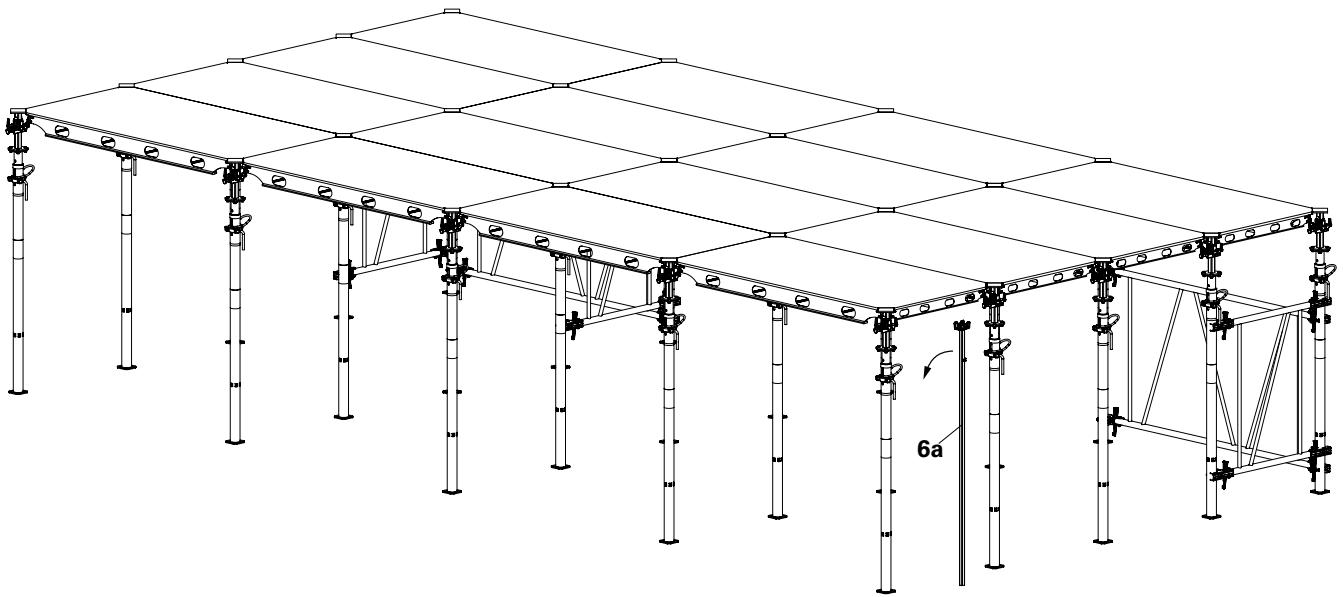

Fig. A4.14

Guidelines for the brace ADB



Warning

Risk of collapse!

A fall can result in serious injuries or even death!

⇒ Bracings must be provided after every third bay in longer direction and every sixth bay in shorter direction. i.e. maximum of 7.2 m spacing between bracings in any direction. (Fig. A4.15)

⇒ Make sure that all drophead ADH wedges are properly tightened before commencement of concreting.

During erection, the ALPHADECK system is stabilized using the brace ADB as per the requirement.

During all subsequent stages, the system requires adequate overall fixity at the soffit. This means that the system is not free standing when loaded.

The stability of the total system relies upon the soffit infill plywood being locked in to the permanent structure such as around column heads or walls.

It is the contractor's responsibility to ensure that the permanent works and the interface with the soffit, as constructed on site, can resist and safely transfer all notional and actual horizontal loads to prevent any collapse.



Fig. A4.15

Company:
 Project:

Checks to be carried out on the construction site before concreting

1. Structure info table

Floor to floor height	=	m
Slab thickness	=	cm
Clear room height	=	m
Extension length for prop load calculation (clear room height - 12 cm)	=	m
Max. panel size	=	cm
Actual prop load (according to Table A4.01)	=	kN
Selected prop	=	
Direction of assembly	Inner bottom	<input type="checkbox"/>	
	Outer bottom	<input type="checkbox"/>	
Perm. prop load (according to PERI Tables)	=	kN
Actual prop load ≤ Perm. prop load	OK	<input type="checkbox"/>	Not OK <input type="checkbox"/>
Pouring method			
Manual	<input type="checkbox"/>	Crane bucket	<input type="checkbox"/>
Pump	<input type="checkbox"/>	Placer boom	<input type="checkbox"/>

3. Ensure that the shuttering/de-shuttering of the system is done as per the job site layout.

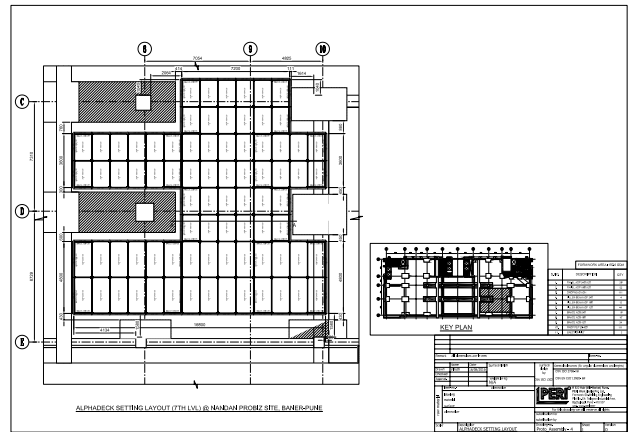

4. For working areas with shuttering height 3 m and above, choose any safe mobile scaffold.

5. It is recommended to use props upright (outer tube at bottom). Drophead fixed to base plate of inner tube.

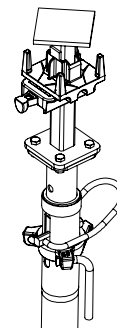

2. Check if all components (panels, dropheads, bracings, props, filler beams) are proper and not damaged.

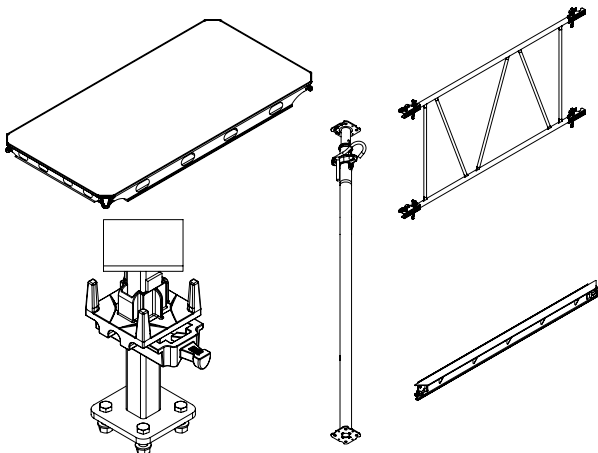

6. Check if all the dropheads are firmly fixed to props using four bolts and nuts.

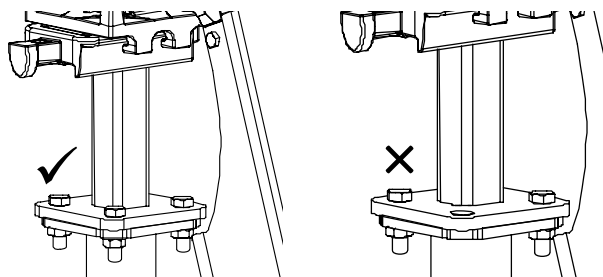

7. Check that the bolt head should be on the drophead side and nut on the prop side.

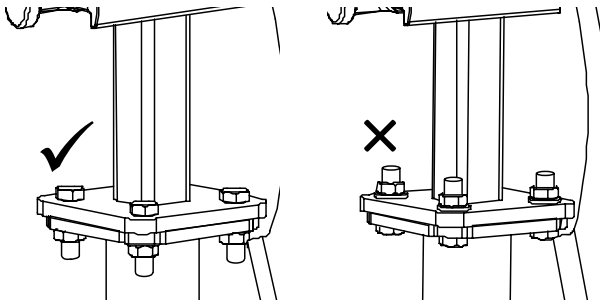

8. Before erection, ensure that all props are set to the same length as required in the project.



9. Check if wedge is tightened fully by using hammer. Check visually if the fly-plate is pressed against the stopper plate.

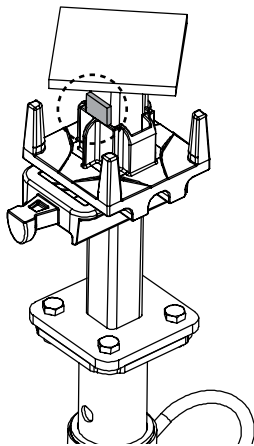

10. During installing the brace ADB, ensure that the bottom wedge has enough clearance 30 cm from the ground for easy removal. Check that all the wedges of the brace ADB are tightened.

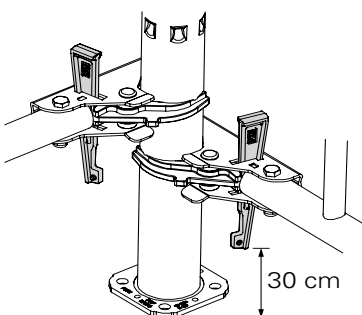
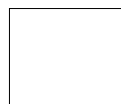

11. The first bay should have three ADB bracings (**2 in shorter direction and 1 in longer direction**).



Bracings must be provided after every third bay in longer direction and every sixth bay in shorter direction. i.e. maximum of 7.2 m spacing between bracings in any direction.

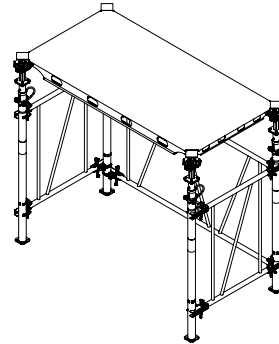

12. For all peripheral props, ensure that the wedge is perpendicular to the panel aout edge.

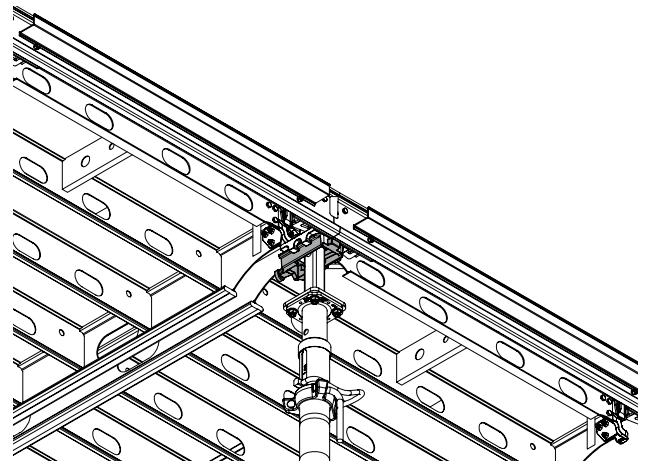

13. For all internal props, ensure that the direction of wedge is parallel to the width of the panel with its nose facing inwards. i.e. opposite to the direction of assembly

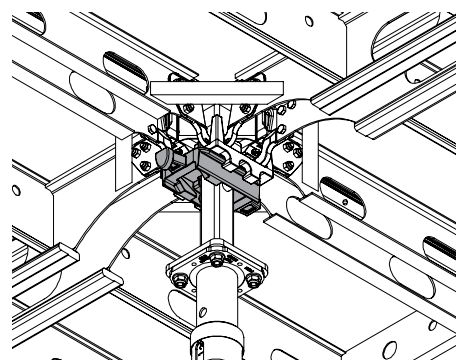

14. Minimum two shuttering aids are required for each assembly.
- Prepare the shuttering aid to the required height before starting the erection. (Prop height + 25 cm)
 - Ensure that the shuttering aid is supporting the panel at the middle edge of the panel.

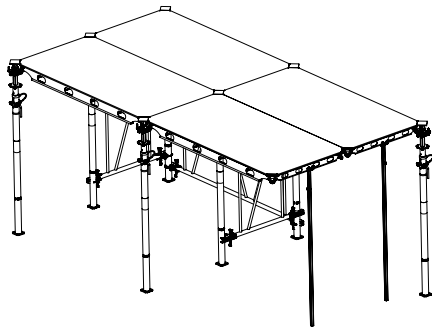

15. Ensure that the filler beam and plywood is installed properly around the ALPHADECK layout.

16. Check if all the props are loaded properly (nut seating on the pin)

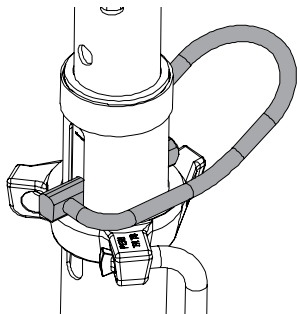

17. Check all props are vertical in both axis by using a magnetic spirit level.
- Check visually if all props are in one line in both panel length and width direction.

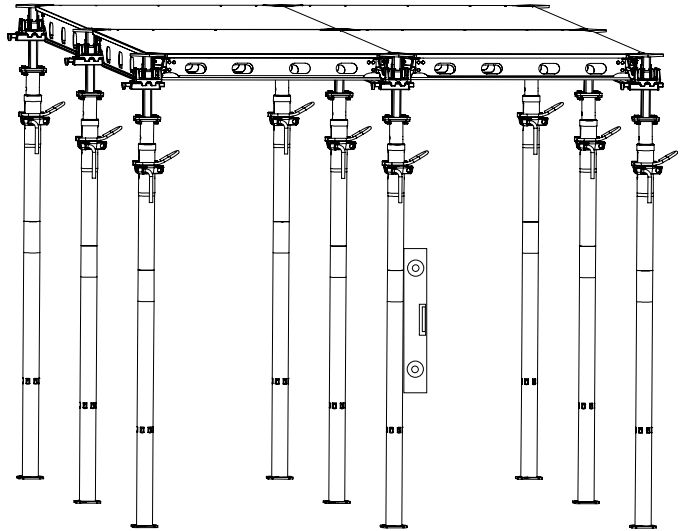

18. After the shuttering is completed, check visually from top if all the panels and drophead top plates are in the same level.

19. Check if additional bracings and chains are required. (e.g. cantilevers, open ends)

20. Do not step on formwork erected at cantilevers until it is firmly secured with Anchor chain 3.0 kN.

Special remarks (if any)

.....

.....

.....

.....

.....

.....

.....

Checked by

Name and Signature:

Date:

Place:

Transverse and longitudinal infills

Max. infills up to 60 cm.



Warning

Risk of falling!

⇒ Personnel could fall down if edges, infills or openings in the slab formwork are not secured!

Forming the infills between 12.5 cm and 60 cm

1. Form the slab with the panel ADP (1) as far as possible, see Section "A4 Shuttering" on page 33.
2. Keep the compensation area as small as possible.
 - The filler beam ADF (8) is compatible for plywood thickness (t) ranging from 12 mm to 18 mm by varying the timber insert (8.3) size. (Fig. A6.02)
 - d = depth of timber insert
 - t = plywood thickness
 - w = width of timber insert



- Infill size up to 60 cm and the no. of supports depend on slab thickness and plywood type (E-modulus and direction of grain). This needs to be checked by contractor.
- Use torx screw 6 x 40 mm (8.1) article no. 024540 to secure the timber insert (8.3) with 12 mm packing (8.2) at every 60 cm c/c. (Fig. A6.02)
- Timber insert (8.3) is not included in the filler beam ADF (8).

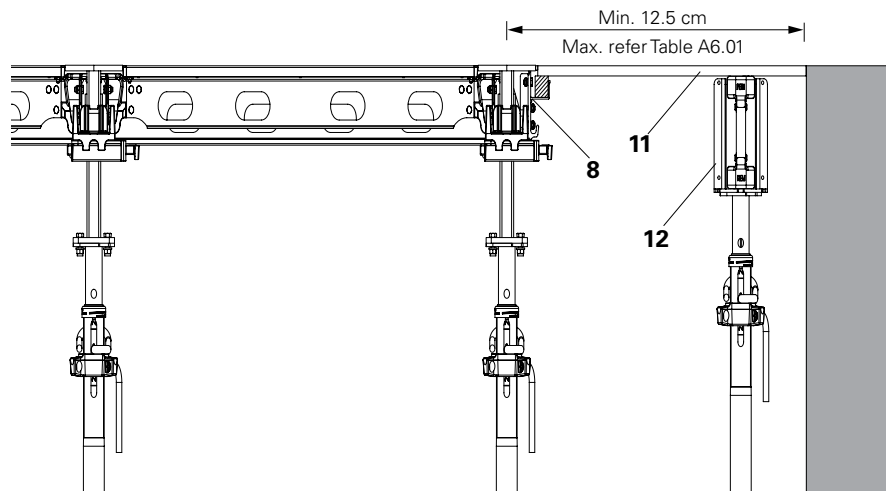

Fig. A6.01

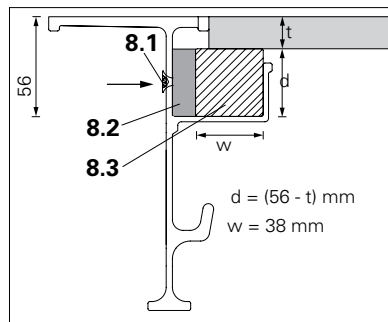

Fig. A6.02

Slab thickness	Max. infill width
Up to 30 cm	60 cm
30 cm - 55 cm	45 cm

Tab. A6.01

Filler beam sizes	Length of timber insert (8.3)
ADF 240	226 cm
ADF 180	166 cm
ADF 120	106 cm

Tab. A6.02

3. Place the filler beam ADF (**8**) on the drophead flyplate pin.
4. Chose correct plywood thickness and cut to size as per the dimension required at site.
5. Erect additional prop (**3**) with MFX crosshead (**12**) and girder VT 20 (**28**).
6. Continuously fill the compensation area with the plywood (**11**). (Fig. A6.03)
7. Secure the plywood (**11**) on top with nails.
→ Do not use more than two nails per the filler beam ADF.

Components

-
- 1** Panel ADP
 - 2** Drophead ADH
 - 3** Prop
 - 8** Filler beam ADF
 - 11** Plywood
 - 12** Multi-flex crosshead
 - 28** Girder VT 20
-

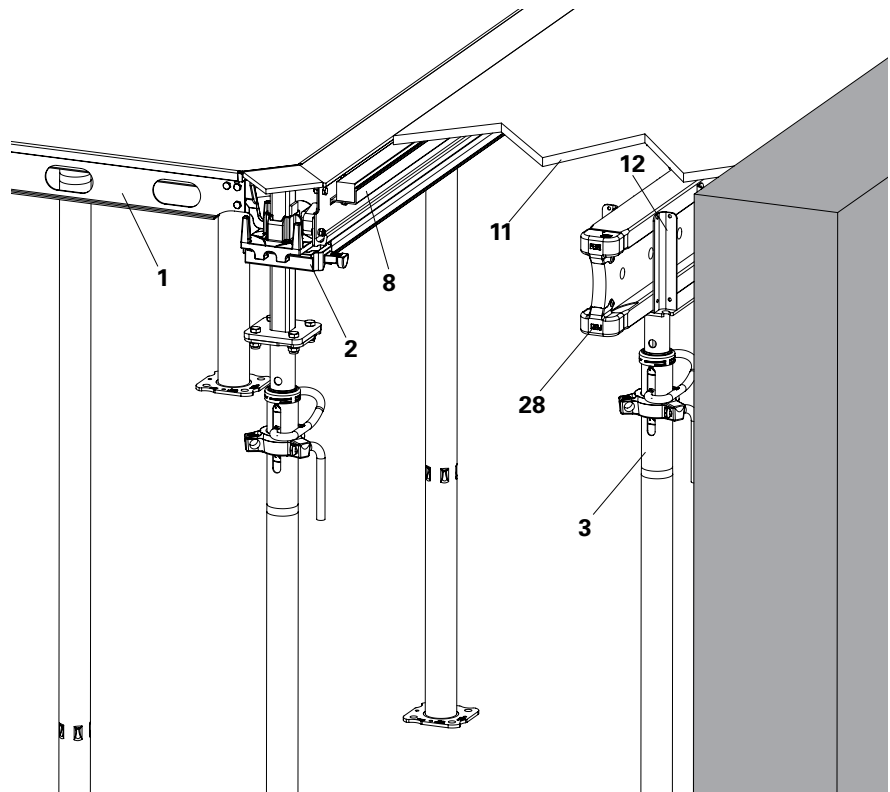

Fig. A6.03

Infill at slab panel corner

Using cross beam head and timber

1. Pre-assembly of the cross beam head (**13**) and timber (**14**) of size 50 x 100 mm should be done on ground.
 - Drill the timber (**14**) and attach the timber to cross beam head (**13**) with 2 no. of bolts and nuts (M10 x 80) (**13.1**) (Article no. 710593 and 710234) on each side. (Fig. A6.04), (Fig. A6.05) and (Tab. A6.02).
2. Always fix the filler beam ADF (**8**) parallel to the longer direction.
3. Fix the cross beam assembly parallel to the shorter direction with one end on the lip of the filler beam ADF (**8**) as shown in (Fig. A6.05a) and other end on the pin of the flyplate (**2.2**) of the drophead ADH (**2**) as shown in (Fig. A6.05b).
4. The assembly is now in position.

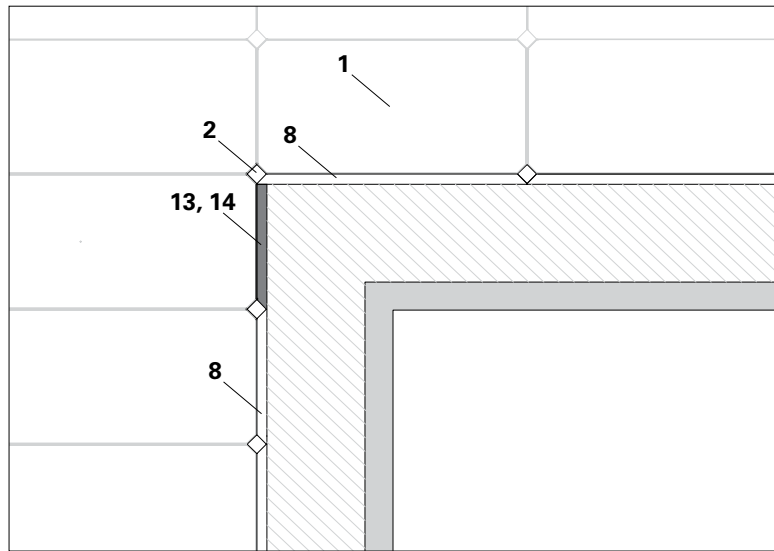

Fig. A6.04

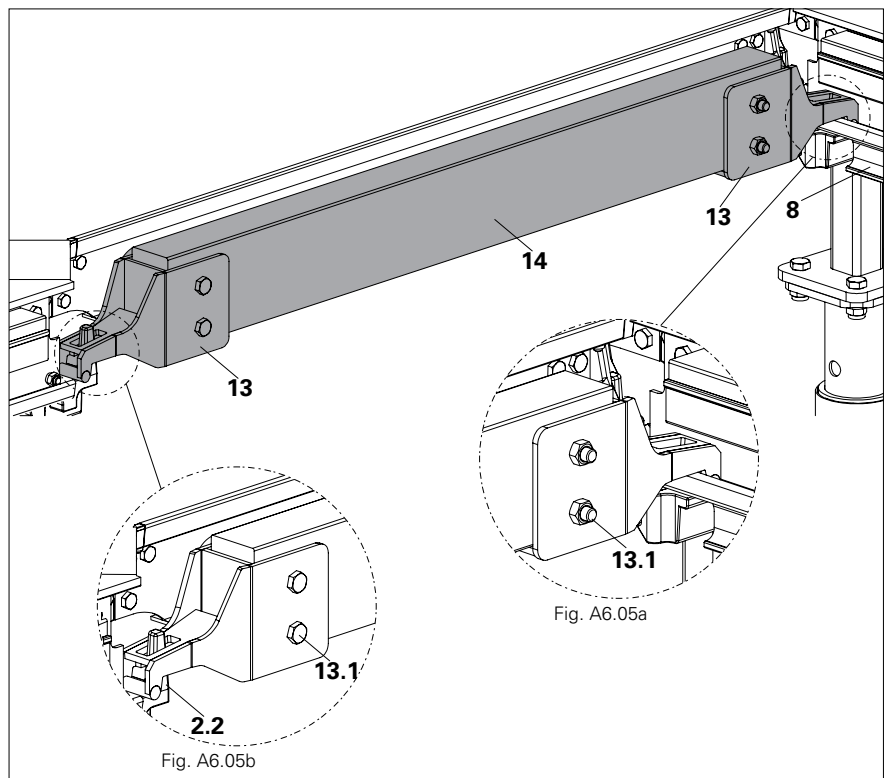

Fig. A6.05



- The maximum slab thickness at the infill location to be in accordance with (Tab. A6.03).

Maximum slab thickness allowed for filler beam	
ADF 180	40 cm
ADF 240	30 cm
Provide extra middle supports beneath the cross beams if slab thickness exceeds mentioned values.	

Tab. A6.03

- The capacity of cross beam head is 3kN.
- The design of the filler area depends on slab thickness, infill width and plywood type (E-modulus and direction of grain). (Tab. A6.04)
- This needs to be checked by the contractor. For any support, consult the PERI design engineer.

t	12 mm	18 mm
a	38 mm	32 mm

Tab. A6.04

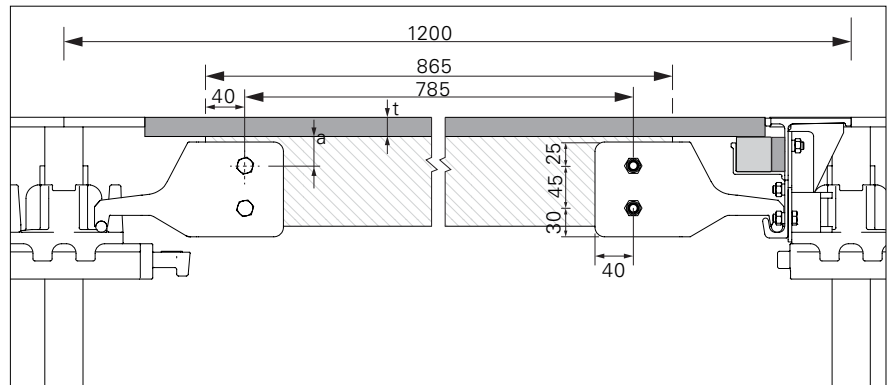

Fig. A6.06

Infill at wall end using corner insert AD

ALPHADECK system can be started from the wall end without the use of a filler beam.

The corner insert AD (**25**) is used to convert a chamfered panel corner into a right-angle corner.

Assembly

1. Shutter the panels 1 to 3, see Section "A4 Shuttering" on page 33. (Fig. A6.07)
2. Hang the panel 4 along with the corner insert (**25**) onto the drophead ADH (**2**) flyplate pin. (Fig. A6.08)
3. Fix the shuttering aid AD (**6**) at the edge rail A (**1.3**) to swing up in shorter direction. (Fig. A6.08)
4. Swing the panel 4 along with corner insert (**25**) upwards using the shuttering aid AD (**6**) and keep it as a temporary support.
5. Support the panel 4 at both ends (shorter direction) with prop (**3**) and crosshead ADC (**16**). (Fig. A6.09)



- The maximum distance between the wall to the center of prop support is 230 mm in shorter direction.
6. Once the prop support is set into position, remove the shuttering aid AD (**6**).

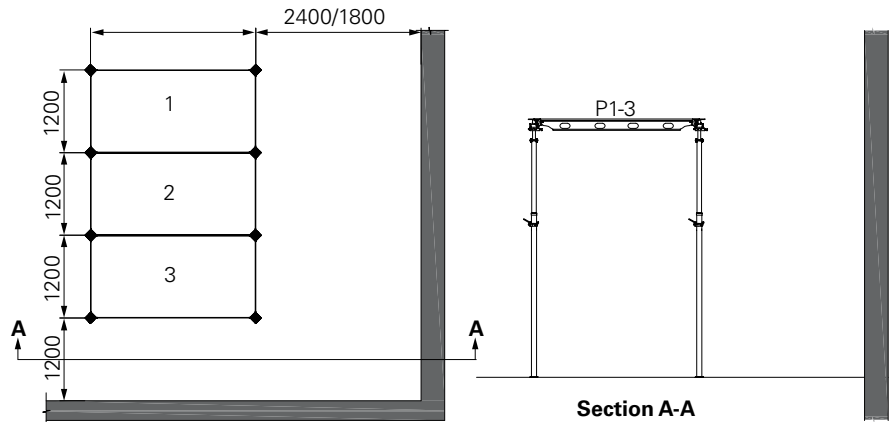

Fig. A6.07

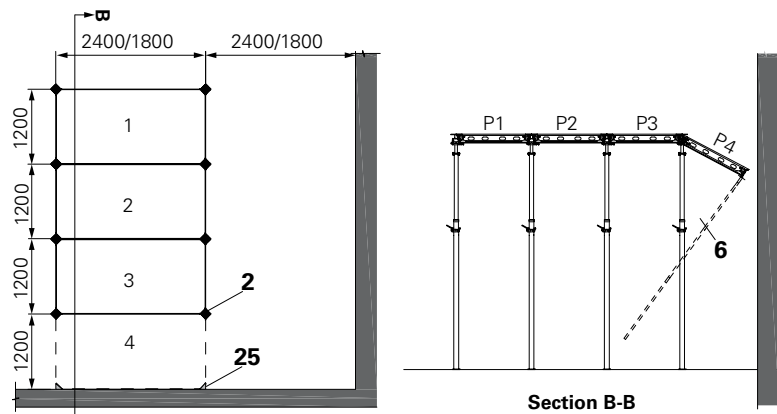

Fig. A6.08

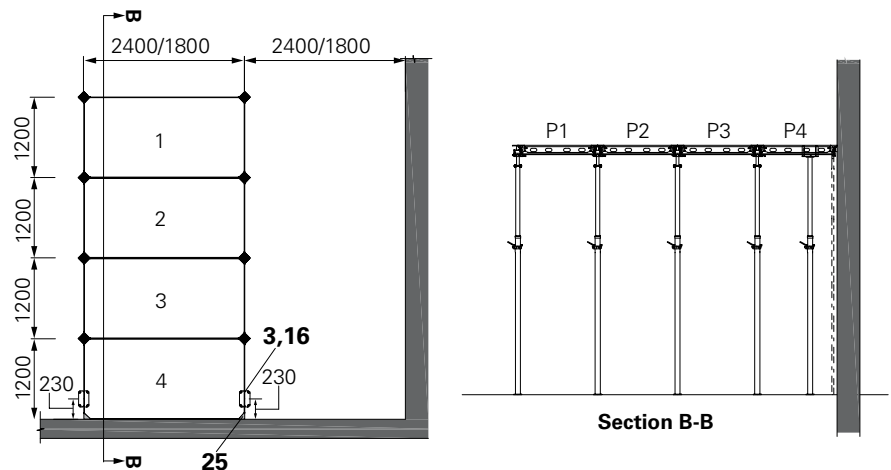

Fig. A6.09

7. Hang the panel 5 along with the corner insert (25) onto the drophead ADH (2) flyplate pin. (Fig. A6.10)
8. Fix the shuttering aid AD (6) at the edge rail B (1.4) to swing up in longer direction. (Fig. A6.10)
9. Swing the panel 5 along with corner insert (25) upwards using the shuttering aid AD (6) and keep it as a temporary support.
10. Support the panel 5 at one end (longer direction) with prop (3) and crosshead ADC (16). (Fig. A6.11)



- The maximum distance between the wall to the center of prop support is 400 mm in longer direction.
11. Once the prop support is set into position, remove the shuttering aid AD (6).
 12. Repeat the steps 7-11 to install the panel 6 and panel 7. (Fig. A6.12)
 13. Place the panel 8 along with corner insert (25) from the top.
 14. Place the girder VT20 (28) with crosshead ADC (16) and prop (3) in the shorter direction of panel 8. (Fig. A6.13)

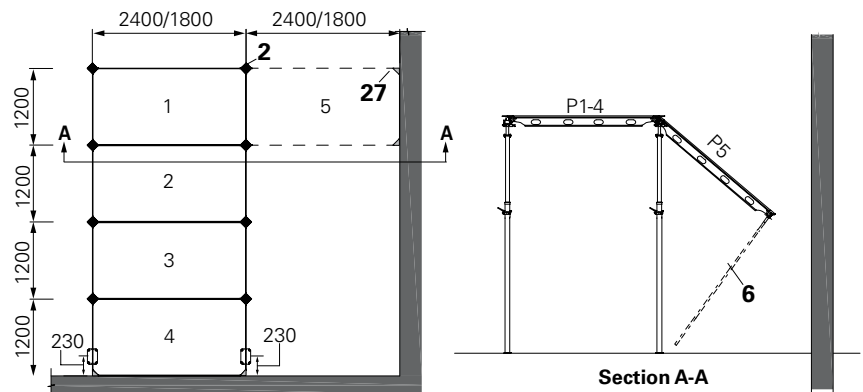

Fig. A6.10

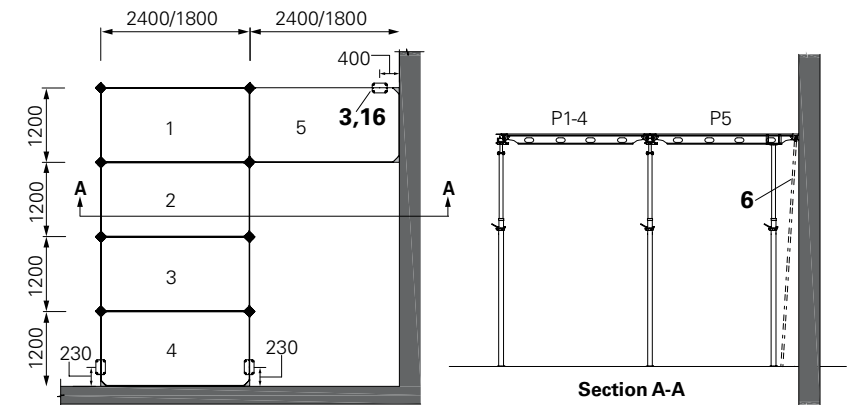

Fig. A6.11

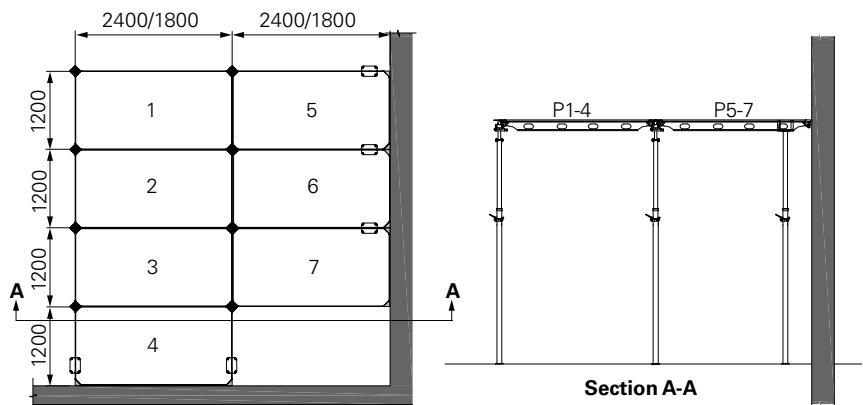

Fig. A6.12

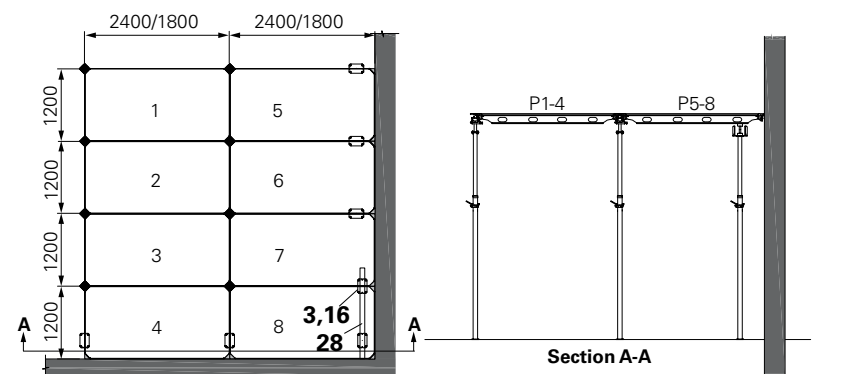

Fig. A6.13

Infill at wall internal corner

Using filler beam ADF and timber

ALPHADECK system can be started at the wall internal corner location using filler beam ADF (8) that touches the wall face in both directions.

Assembly

1. Cut an infill plywood of 36 mm width and length = filler beam length (for e.g. 180 cm for ADF 180) and nail it to the timber infill (8.3) of the filler beam ADF (8). (Fig. A6.14 + Fig. A6.15)
 - Make such similar filler beam assemblies as per project requirements.
2. Prepare a timber block (23) as per dimension shown. Height of timber H (in mm) = 120 - plywood thickness (Fig. A6.16)
3. Assemble the timber block (23) on flyplate pin of the drophead (2) at corner position and lock the wedge.
4. Erect the prop (3) attached with drophead (2) and timber block (23) at the wall corner in such a way that the timber block (23) touches the wall face in both directions. (Fig. A6.15)
5. Erect two other props to complete the L-shaped corner and fix the brace ADB, see Section "A4 Shuttering" on page 33.
6. Install the filler beam assemblies made as per step 1 on the flyplate pins at the same L-shaped corner.
7. Now, install the panel ADP (1) at the L-shaped corner.
8. Similarly, repeat the process along the wall lengths in both directions and complete the ALPHADECK system assembly, see Section "A4 Shuttering" on page 33.

Plywood cutting pattern

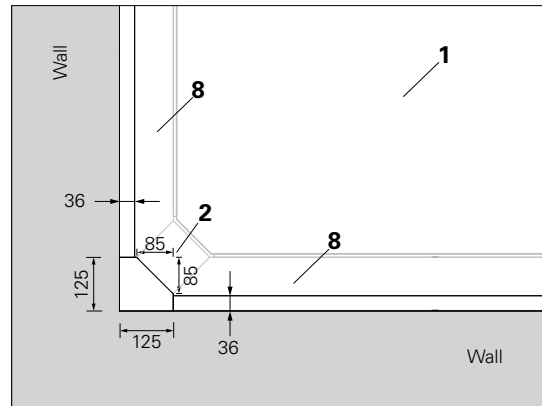

Fig. A6.14

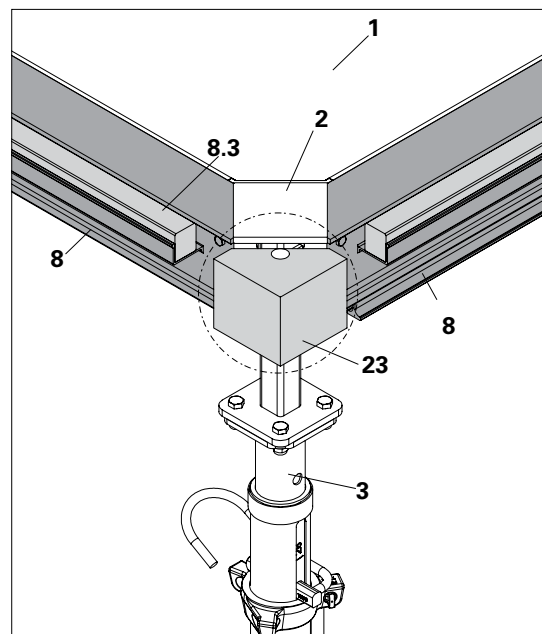

Fig. A6.15

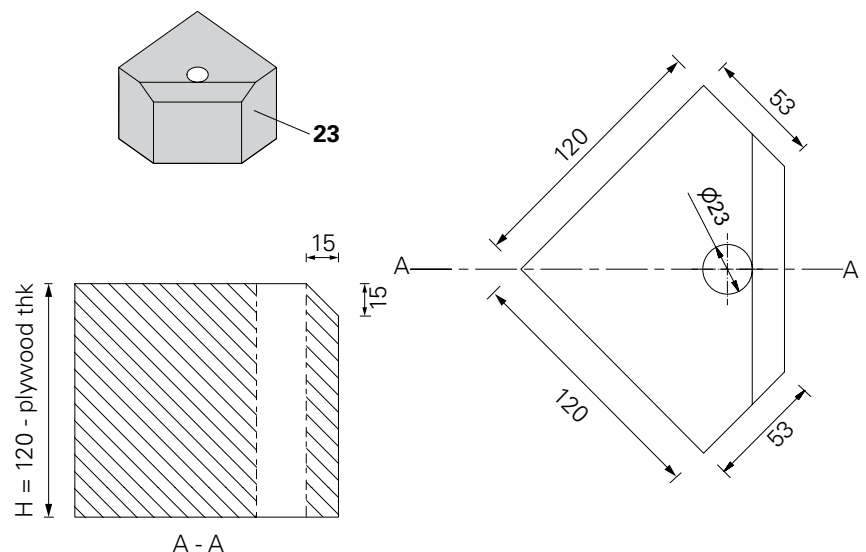

Fig. A6.16

Infill at beam internal corner

Using filler beam ADF and timber

ALPHADECK system can also be started at the beam internal corner location using filler beam ADF (8) on one side.

Assembly

1. Cut infill plywood of suitable sizes as per plywood cutting option 1 or 2. (Fig. A6.17 + Fig. A6.18)
2. Prepare a timber block (23) as per dimension shown where height of timber ($H = 120 - \text{plywood thickness}$). (Fig. A6.16)
3. Assemble the timber block (23) on flyplate pin of the drophead (2) near to beam corner position and lock the wedge. (Fig. A6.15)
4. Erect the prop (3) attached with drophead (2) and timber block (23) near to the beam corner (distance varies according to the infill area. e.g. 300 mm). (Fig. A6.17 + Fig. A6.18) (alternatively timber block (23) can be installed from top)
5. Complete the ALPHADECK panel assembly, see Section "A4 Shuttering" on page 33.
6. Now, hook the filler beam ADF (8) on the flyplate pin and swing it using shuttering aid.
7. Similarly, repeat the process along the beam lengths in both directions near to the infill areas.
8. Complete the compensation areas on both sides as described in transverse and longitudinal infills using plywood made as per Step 1.

Plywood cutting pattern - option 1

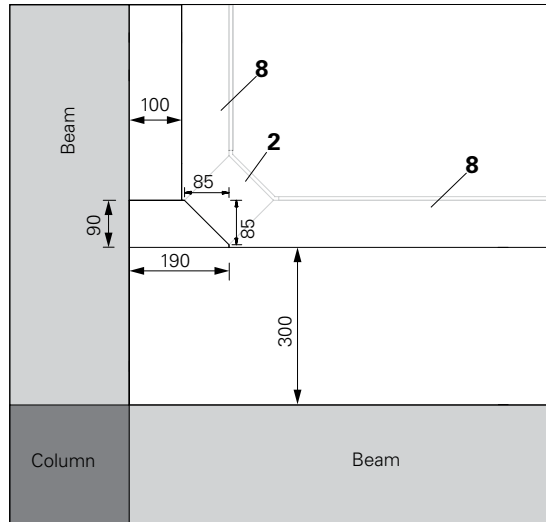

Fig. A6.17

Plywood cutting pattern - option 2

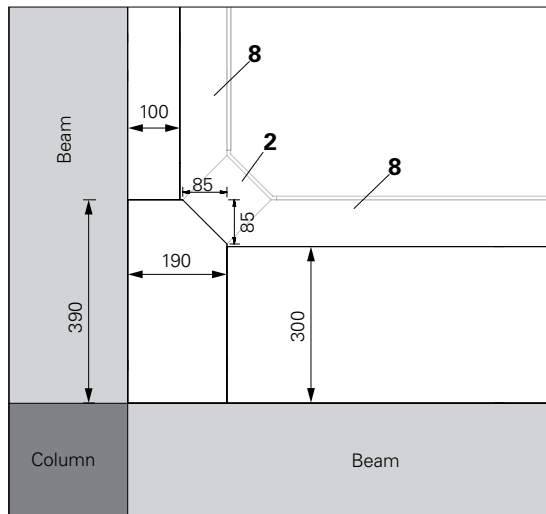

Fig. A6.18



Infill size and the no. of support depends on slab thickness and plywood type (E-modulus and direction of grain). This needs to be checked by contractor.

Columns within the panel grid



Warning

Risk of falling!

⇒ Personnel could fall down if edges, infills or openings in the slab formwork are not secured!

1. Form the slab with panel ADP (1) as close as possible to the column.
2. Place the filler beam ADF (8) on the drophead flyplate pin in the longer direction. (Fig. A7.01)
3. Cut the timber (14) size 50 x 100 mm as per required length.
4. Pre-assembly of cross beam head (13) and timber (14) size 50 x 100 mm should be done on ground. Drill the timber (14) and attach the timber to cross beam head with 2 no. of bolts and nuts (M10 x 80) (13.1) (Article no. 710593 and 710234) on each side. (Fig. A7.02), (Fig. A7.03) and (Tab. A7.02)

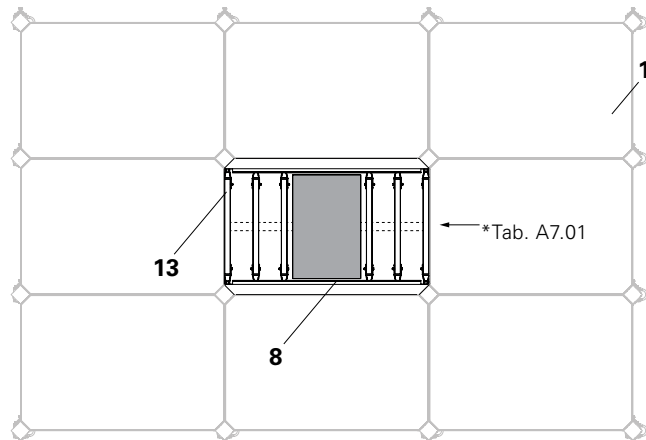

Fig. A7.01

Maximum slab thickness allowed for filler beam		
ADF 180	40 cm	* Provide extra middle supports beneath the cross beams if slab thickness exceeds mentioned values
ADF 240	30 cm	

Tab. A7.01

t	12 mm	18 mm
a	38 mm	32 mm

Tab. A7.02

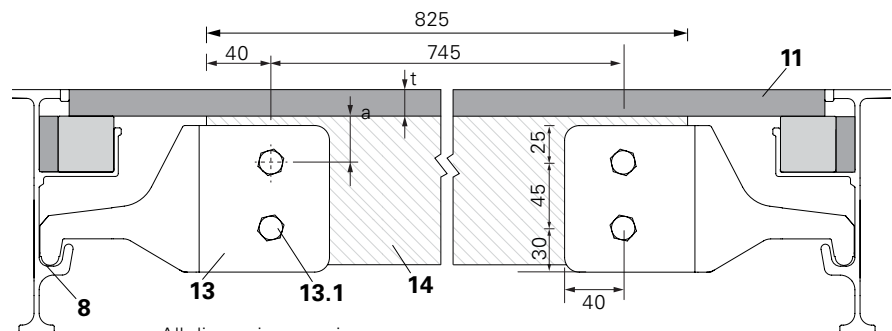

Fig. A7.02



The capacity of cross beam head is 3 kN.

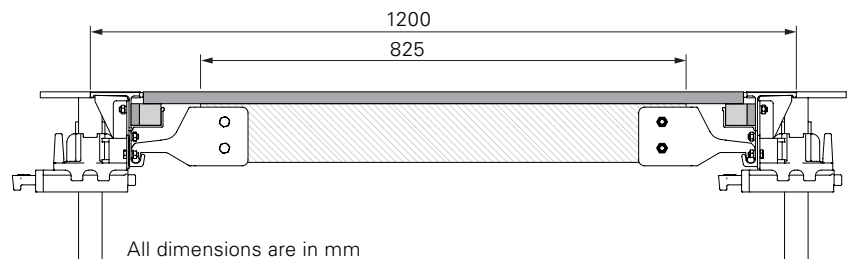

Fig. A7.03

A7 Shuttering around columns

- 5. Place the assembly of cross beam head with timber into lips of the filler beam ADF (8) on both sides. (Fig. A7.04a)
- 6. Place similar assemblies from panel end face up to the column. (Fig. A7.04)



Number of cross beams and any middle supports required depend on slab thickness and plywood type (E-modulus and direction of grain). This needs to be checked by contractor.

- 7. Cut the plywood to required size.
- 8. Fill the column compensation area with the plywood.
- 9. Secure the plywood on top with nails.

Components

- 1 Panel ADP
- 8 Filler beam ADF
- 13 Cross beam head
- 13.1 Bolt and nut (M10 x 80)
Article no. 710593 and 710234
- 14 Timber size 50 x 100 mm

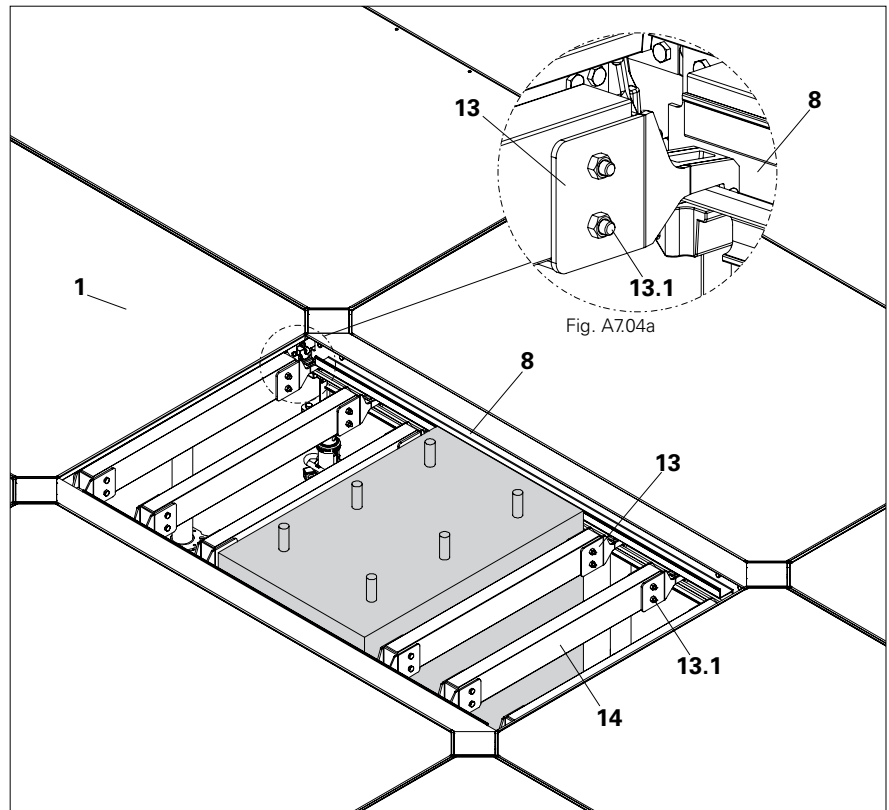

Fig. A7.04

Using corner insert AD

The change of direction is also possible in the ALPHADECK system by using the corner insert AD.

Assembly

1. Shutter the panels 1 to 4, see Section "A4 Shuttering" on page 33.
2. Hang the panel 5 and panel 6 along with corner insert AD (**25**) onto the drophead ADH (**2**) flyplate pin. (Fig. A8.01)
3. Fix the shuttering aid AD (**6**) at the edge rail B (**1.4**) of panel 5 to swing up in longer direction and keep shuttering aid as temporary support.
4. Repeat the Step 3 for the panel 6 and keep additional shuttering aid as a temporary support.
5. Support the joints of panel 5 and 6 at longer direction with prop (**3**) and crosshead ADC (**16**). (Fig. A8.02)



- The maximum distance between the edge rail B to the center of prop support is 400 mm in longer direction.
6. Once the prop support is set into position, remove the temporary supports.
 7. Repeat the Step 2 to 6 for panel 7 and 8.
 8. At the transition to the change of direction (**C**), assemble panel 9 and 10, see Section "A4 Shuttering" on page 33.
- The change of direction is prepared.

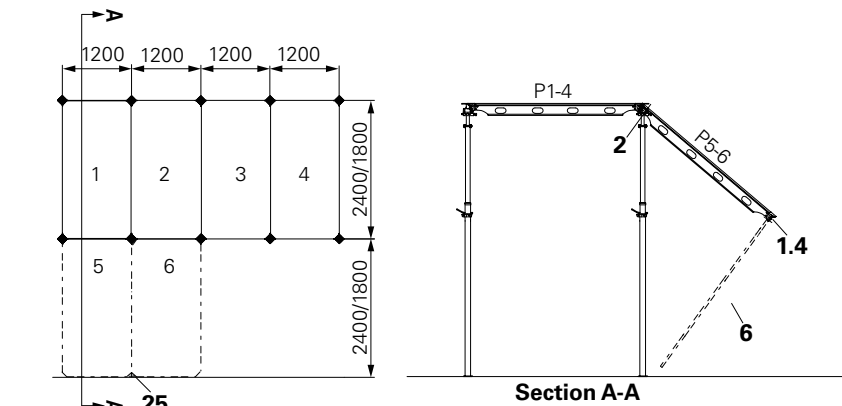

Fig. A8.01

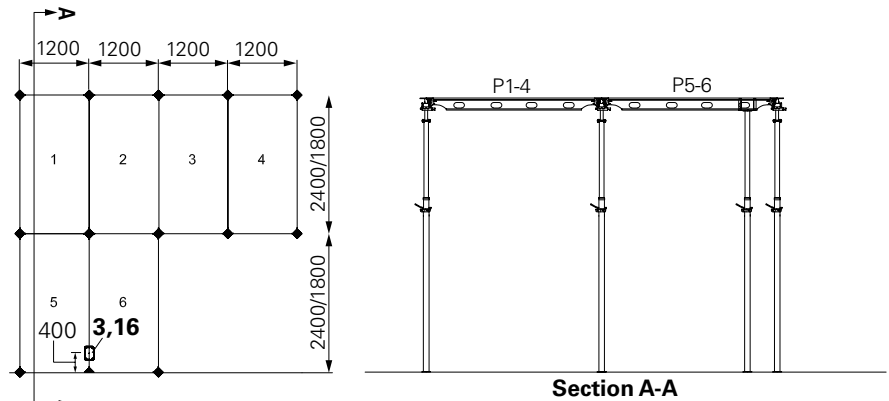

Fig. A8.02

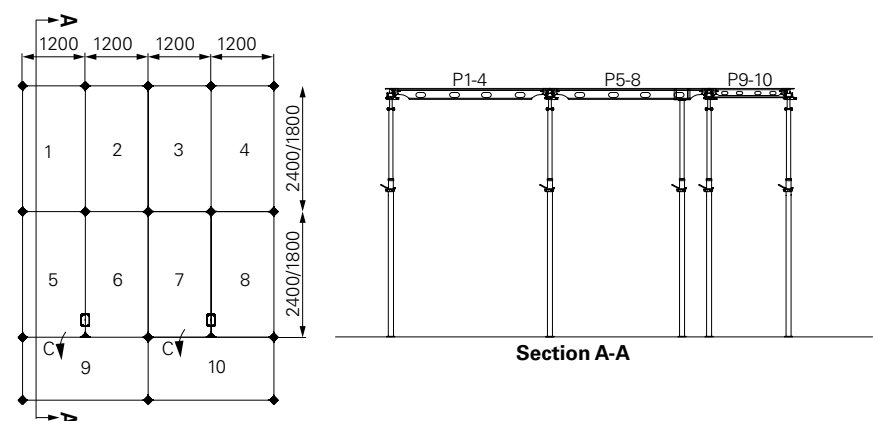
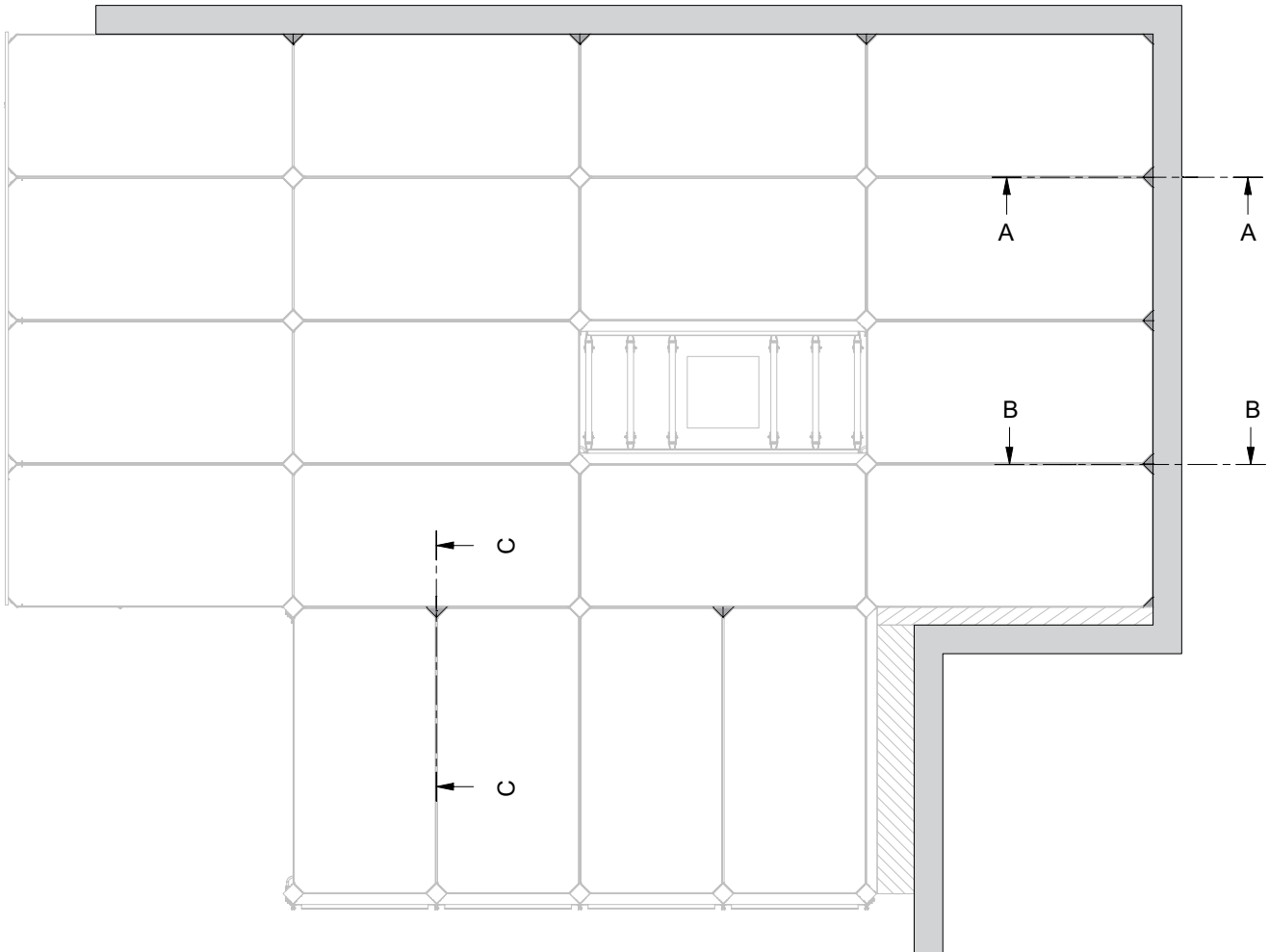

Fig. A8.03

A8 Change of direction

ALPHADECK layout



A - Infil at wall end

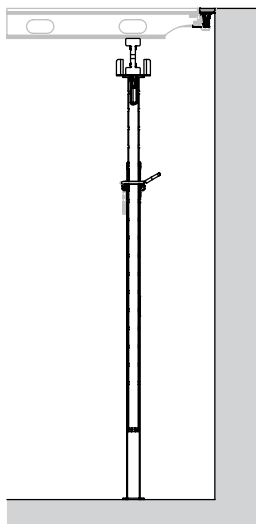

B - Infil at wall end

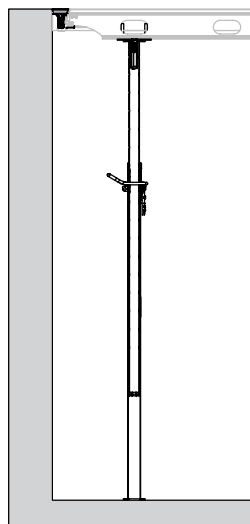

C - Change of direction

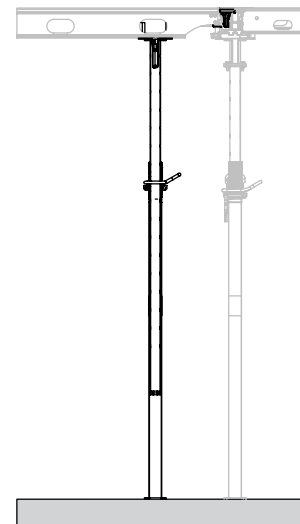

Guardrail holder ADG with guardrail post HSGP-2

The guardrail holder ADG with guardrail post HSGP-2 secures site personnel working on a casting segment against falling in both directions.

The guardrail holder ADG can be installed in longer and shorter direction.

Design width of influence is 1.2 m for guardrail holder ADG.



Warning

Risk of falling!

During assembly of the guardrails, measures must be taken to prevent falling, e.g. PPE!

Assembly

1. For shorter direction:
Place the guardrail holder (9) into the stiffener hole (1.8) of the panel.
Put the pin (9.1) in the same hole and lock it using cotter pin.
(Fig. A9.01 + Fig. A9.02)
2. For longer direction:
Place the guardrail holder (9) into the hole (1.5) provided on the cross strut C of the panel. (Fig. A9.04a)
Put the pin (9.1) in the same hole and lock it using cotter pin.
3. To tighten the guardrail holder, hammer its wedge as shown in arrow mark. (Fig. A9.02)

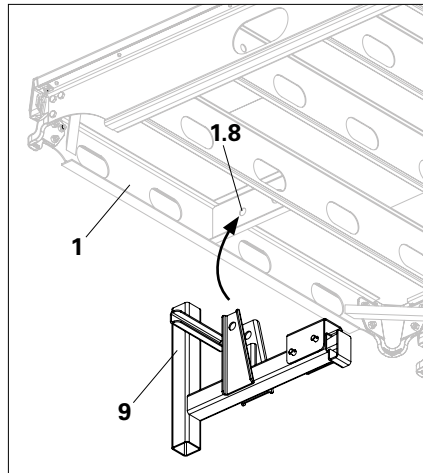

Fig. A9.01

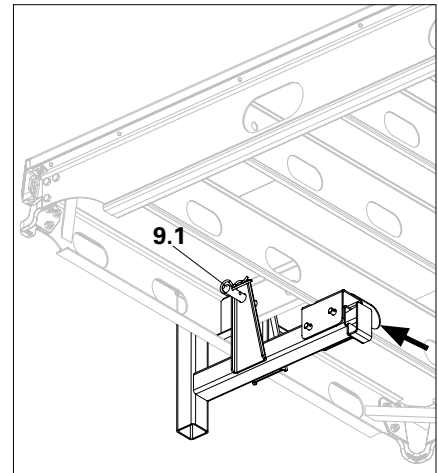

Fig. A9.02

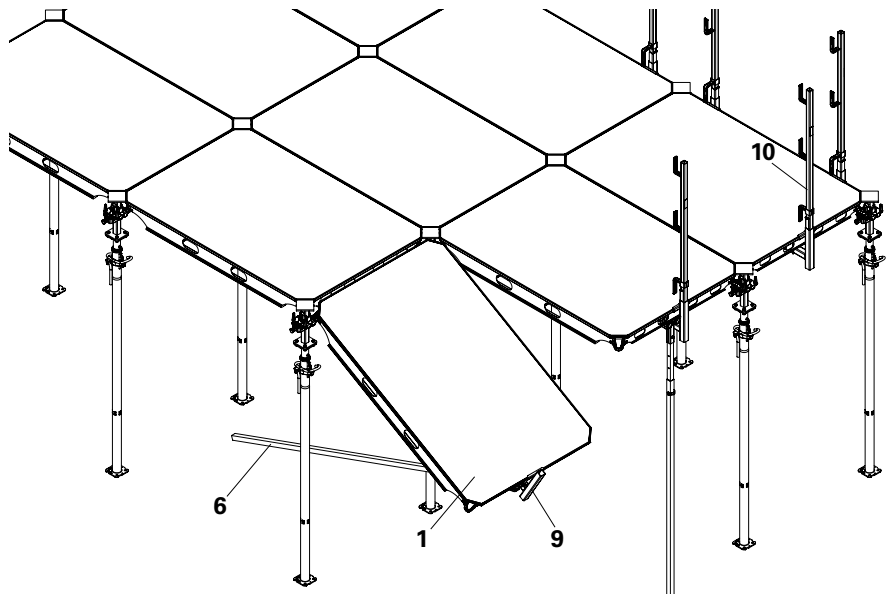

Fig. A9.03

4. Swing the panel ADP (1) along with guardrail holder (9) upwards using the shuttering aid (6). (Fig. A9.03)
5. Insert the guardrail post HSGP-2 (10) into the guardrail holder (9) from top. (Fig. A9.03)
Step on top of formwork to insert guardrail post HSGP-2 (10) only after the system is firmly secured.
6. Insert the guardrail boards (15) and secure with nails. (Fig. A9.04)

Components

-
- 9** Guardrail holder ADG
 - 10** Guardrail post HSGP-2
 - 15** Guardrail boards
-

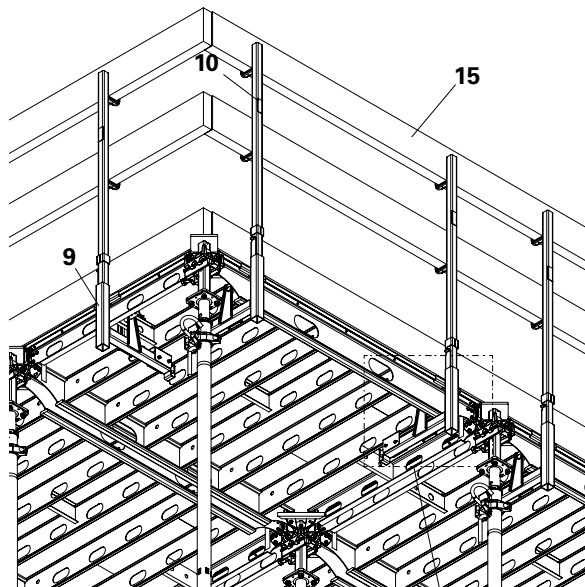

Fig. A9.04

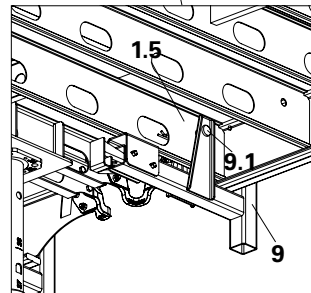

Fig. A9.04a

Cantilever in longer direction of the panel

Permissible load: 150 kg/m² on working area (W)



- Cantilevers are secured against toppling using anchor chain 3.0 kN (17).
- Additional chain bracings (17a) must be installed for transfer of horizontal loads due to open slab edges.
- Project specific planning is to be taken in to account for the number of additional chains required.



Warning

Risk of falling!

- ⇒ Ensure that end-to-end side protection is installed on slabs that have been completed!
- ⇒ Formwork erected at cantilevers must not be stepped on before being firmly secured with anchor chains and Z-bracings!
- ⇒ Work to be carried out by qualified personnel only!

Using the panel ADP 240

Plan the projection of the slab P [20 cm max. from the prop center to the slab edge] and the width of the working area W [75 cm max.] in accordance with illustration. (Fig. A10.01a)

Panel ADP 240

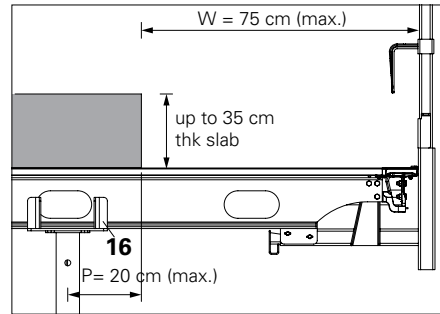

Fig. A10.01a

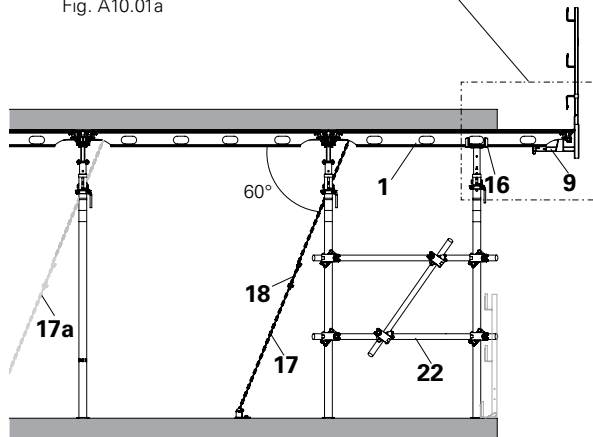

Fig. A10.01

Using the panel ADP 180

Plan the projection of the slab P [15 cm max. from the prop center to the slab edge] and the width of the working area W [60 cm max.] in accordance with illustration. (Fig. A10.02a)

Assembly

1. Install the panel ADP (1) along with guardrail holder ADG (9). (Fig. A10.02)
2. Attach the crosshead ADC (16) with prop to support the panel ADP (1).
3. Secure the cantilever using anchor chain 3.0 kN (17). (Fig. A10.02 + Fig. A10.03)
 - Attach the anchor chain (17) to the hole (1.9) provided on stiffener (1.6) of the panel ADP (1). (Fig. A10.03)
4. Install additional Z-bracings for stability of props at periphery. e.g. bracings using pipes and couplers. (Fig. A10.02)

Panel ADP 180

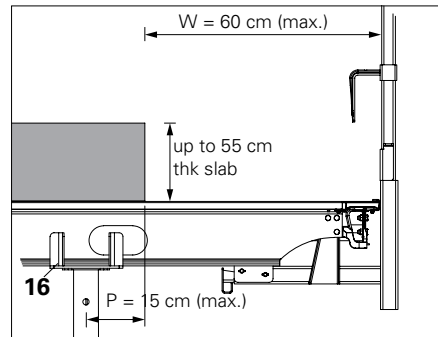

Fig. A10.02a

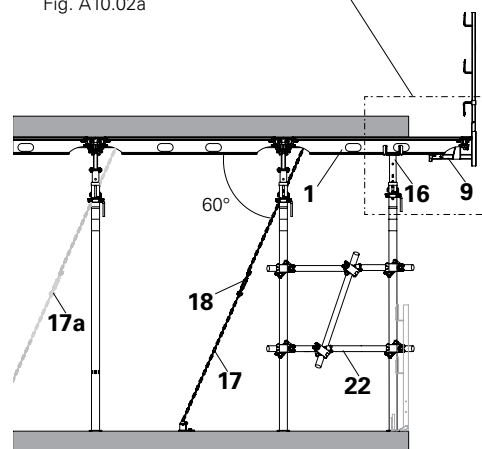

Fig. A10.02

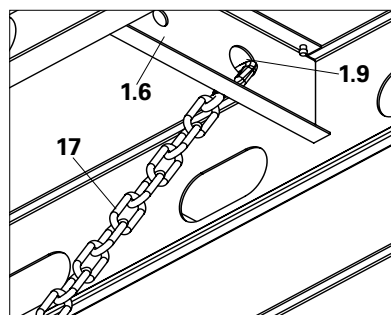

Fig. A10.03

5. Insert the guardrail post HSGP-2 (**10**) into the guardrail holder (**9**) from top only after it is firmly secured with anchor chains. (Fig. A10.04)
6. Insert the guardrail boards (**15**) and secure with nails. (Fig. A10.04)

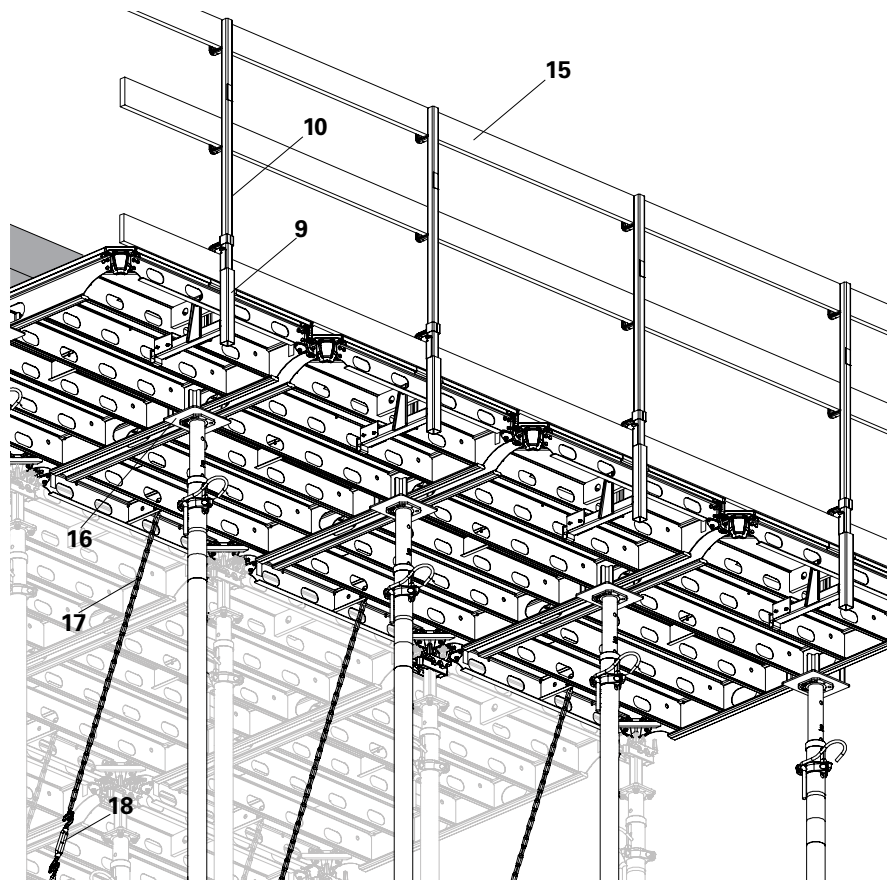

Fig. A10.04

Tensioning using anchor chain 3.0 kN

1. Mount RS base plate (**19**) on the existing construction with the PERI anchor bolt 14/20 x 130 (**21**). Bracing angle 60°. (Fig. A10.05)
2. Attach the 3.0 kN anchor chain (**17**) to the 3.0 kN turnbuckle (**18**) and attach the 3.0 kN turnbuckle (**18**) to the RS base plate. (Fig. A10.05)
In case of longer lengths, use two anchor chains connected with turnbuckle in the middle.
3. Tighten the turnbuckle (**18**) until the anchor chain is taut using pins and cotter pins (**20**). (Fig. A10.05)

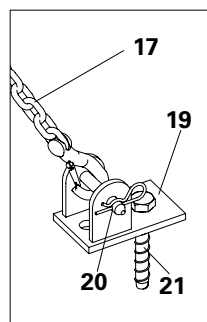

Fig. A10.05

Cantilever in shorter direction of the panel

Permissible load: 150 kg/m² on working area (W)



- Cantilevers are secured against toppling using anchor chain 3.0 kN (17).
- Additional chain bracings (17a) must be installed for transfer of horizontal loads due to open slab edges.
- Project specific planning is to be taken in to account for the number of additional chains required.

Warning

Risk of falling!

- ⇒ Ensure that end-to-end side protection is installed on slabs that have been completed!
- ⇒ Formwork erected at cantilevers must not be stepped on before being firmly secured with anchor chains and Z-bracings!
- ⇒ Work to be carried out by qualified personnel only!

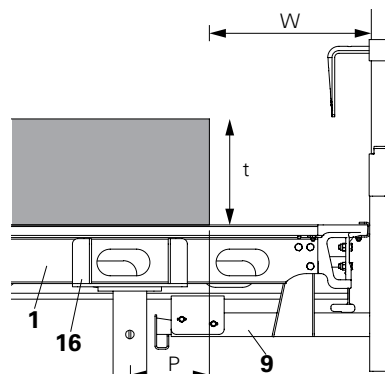

Fig. A10.06a

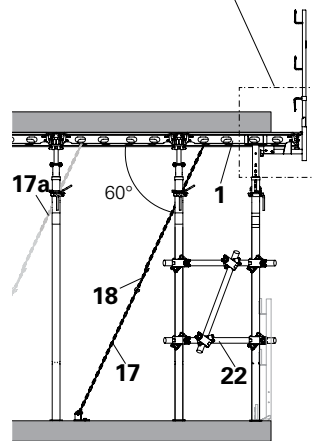

Fig. A10.06

Panel ADP 240		
Slab thickness	W	P
$t \leq 250$	300	100
$250 < t \leq 350$	200	60

Tab. A10.01

Panel ADP 180		
Slab thickness	W	P
$t \leq 400$	300	100
$400 < t \leq 550$	150	100

Tab. A10.02

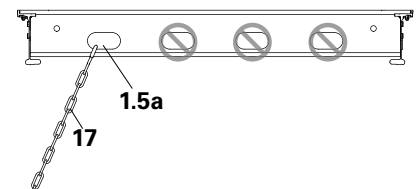

Fig. A10.07

Using Panel ADP 240

Plan the projection of the slab P (from the prop center to the slab edge) and the width of the working area W in accordance with (Fig. A10.06a) and (Tab. A10.01)

Using Panel ADP 180

Plan the projection of the slab P (from the prop center to the slab edge) and the width of the working area W in accordance with (Fig. A10.06a) and (Tab. A10.02)

Assembly

1. Install the panel ADP (1) along with guardrail holder ADG (9). (Fig. A10.06a)
2. Attach crosshead ADC (16) with prop to support the panel ADP (1).
3. Secure the cantilever using anchor chain 3.0 kN (17). (Fig. A10.06a) Attach anchor chain (17) only on the first slot (1.5a) provided on the outermost cross strut C of the panel ADP (1) (Fig. A10.07)
4. Install additional Z-bracings (22) for stability of props at periphery. e.g. bracings using pipes and couplers. (Fig. A10.06)

Panel ADP 240

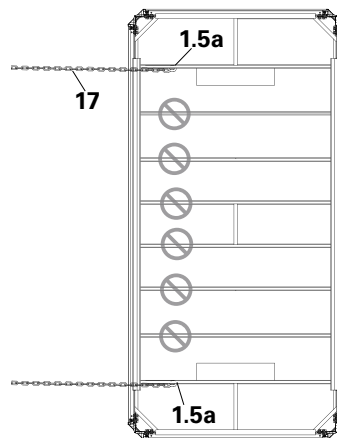

Fig. A10.08

Panel ADP 180

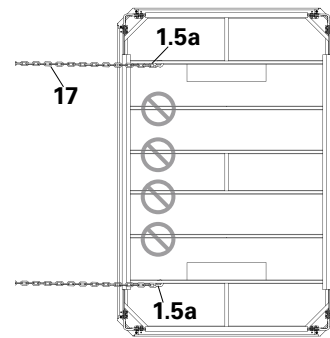

Fig. A10.09



Use two no. of chains per panel as shown in illustration. (Fig. A10.08 + Fig. A10.09)



Do not attach the anchor chain 3.0 kN (17) on any place other than the first slot (1.5a) provided on the outermost cross strut C of the panel. (Fig. A10.06a + Fig. A10.08 + Fig. A10.09),

5. Insert the guardrail post HSGP-2 (**10**) into the guardrail holder (**9**) from top only after it is firmly secured with anchor chains. (Fig. A10.10)
6. Insert guardrail boards (**15**) and secure with nails. (Fig. A10.10)

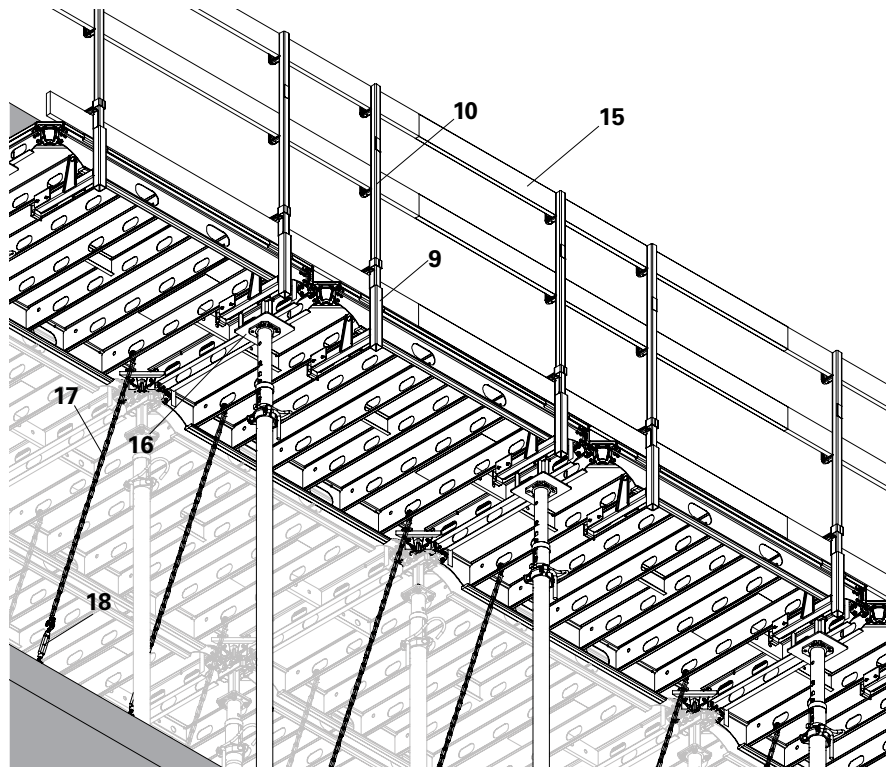

Fig. A10.10

Tensioning using anchor chain 3.0 kN

1. Mount RS base plate (**19**) on the existing construction with the PERI anchor bolt 14/20 x 130 (**21**). Bracing angle 60°. (Fig. A10.11)
2. Attach the 3.0 kN anchor chain (**17**) to the 3.0 kN turnbuckle (**18**) and attach the 3.0 kN turnbuckle (**18**) to the RS base plate.

In case of longer lengths, use two anchor chains connected with turn buckle in the middle.

3. Tighten the turnbuckle (**18**) until the anchor chain is taut using pins and cotter pins (**20**). (Fig. A10.10)

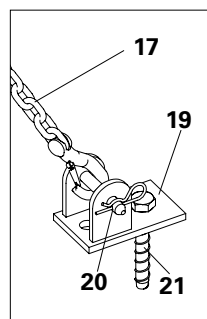

Fig. A10.11

When early striking is required

Warning

Risk of collapse!

Consequences of non-compliance.

⇒ Deshuttering to start only when the concrete has sufficiently hardened and the person in charge has given the go-ahead for striking to take place.



- Deshuttering of the system should start from infill areas.
- Striking is carried out by means of a safe mobile scaffold.
- Before commencement of deshuttering, all bracings should be removed and stacked properly.

Deshuttering the filler beam ADF

1. Get access to the safe infill areas.
2. Strike the drophead wedge with a hammer at infill corner. This causes the filler beam ADF to drop by 12 cm.
3. Remove the filler beam ADF.

Lowering of the panels

1. Strike the drophead wedge with a hammer. (Fig. A11.01)
2. Strike the next drophead wedge on one side row by row as shown by arrow mark. This causes the panels to drop by 12 cm. (Fig. A11.02)
3. Similarly, release all the wedges as shown in step 1 & 2.

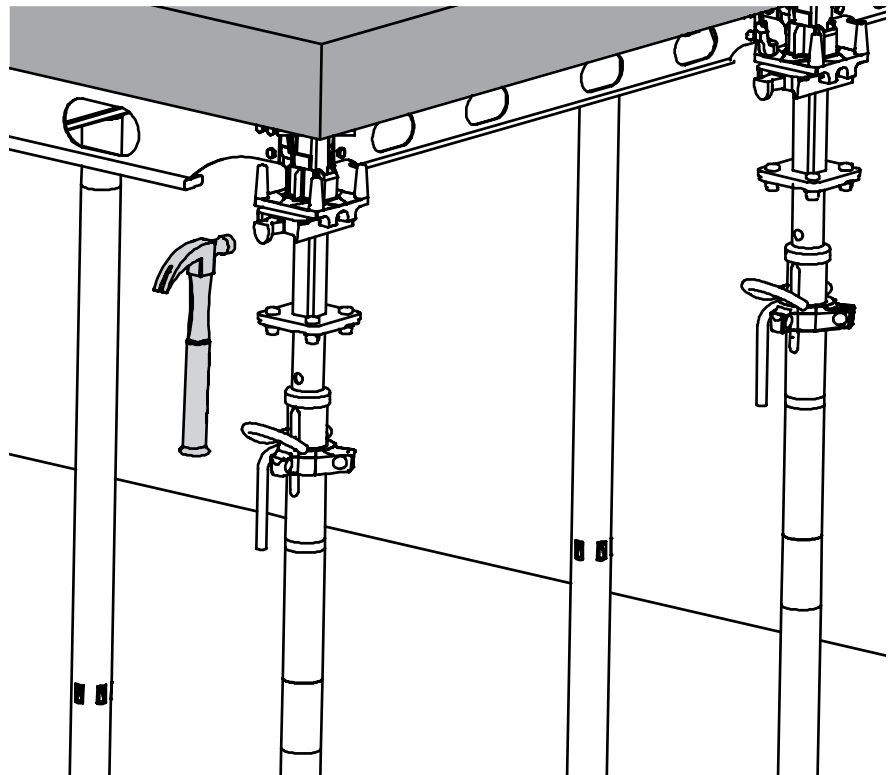

Fig. A11.01

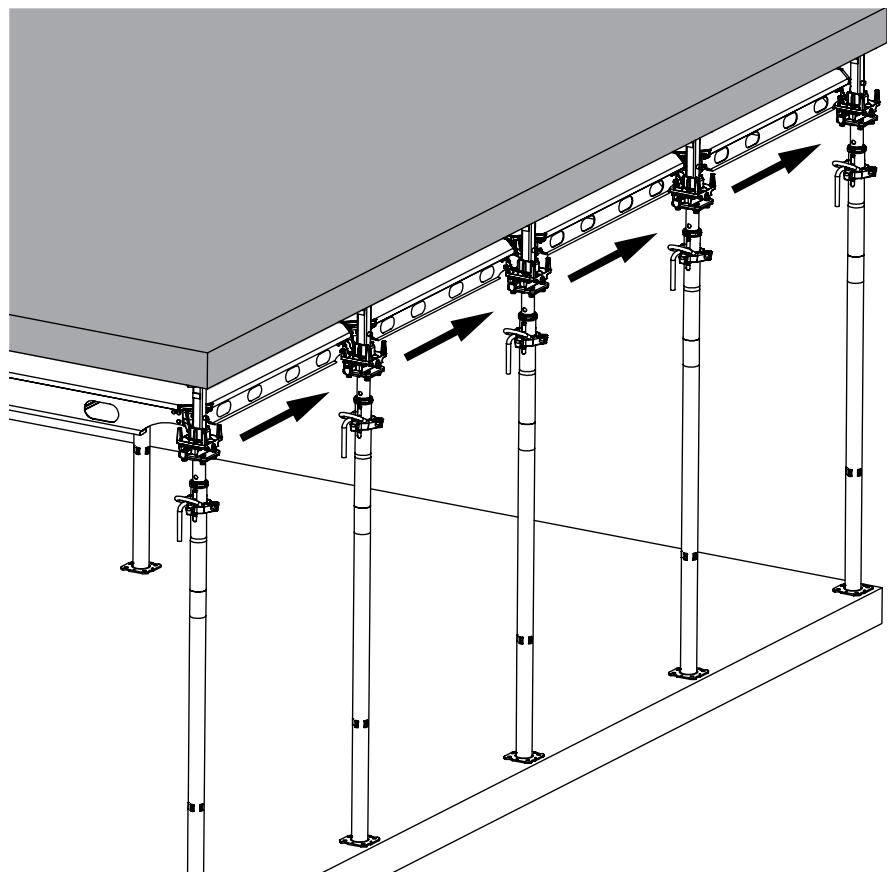

Fig. A11.02

After striking all the wedges by hammer, the panels are now released from the concrete surface. (Fig. A11.03)

This allows easy de-shuttering of panels in both shorter and longer directions.

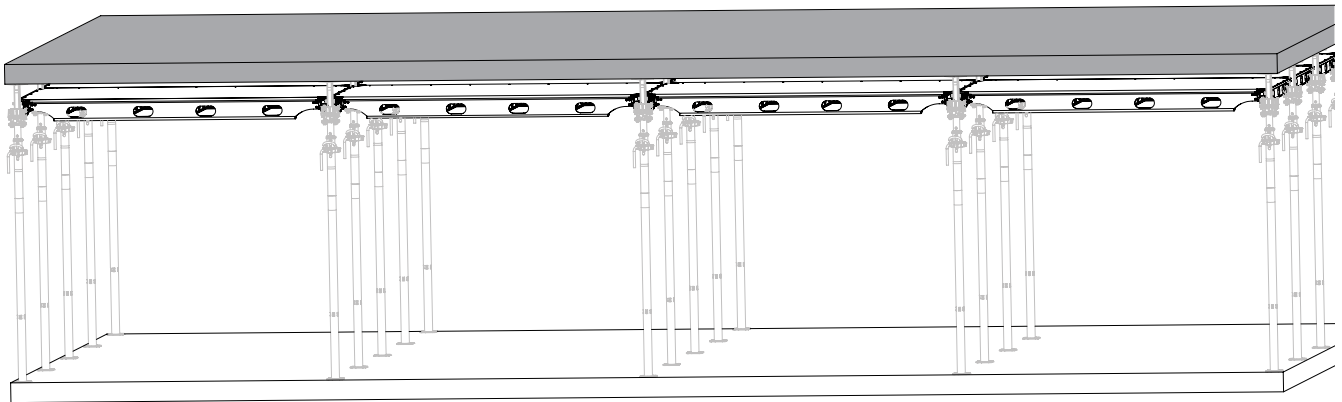

Fig. A11.03

Removing the panels in longer direction



Use safe mobile scaffold while removing the panels.

1. To remove the panel from its position, lift the panel from flyplate pin.
2. Push the panel horizontally till the panel clears the flyplate pin by 30 mm. (Fig. A11.04)
3. Tilt the panel and bring it to the ground.
See sequence shown in Fig. A11.04a

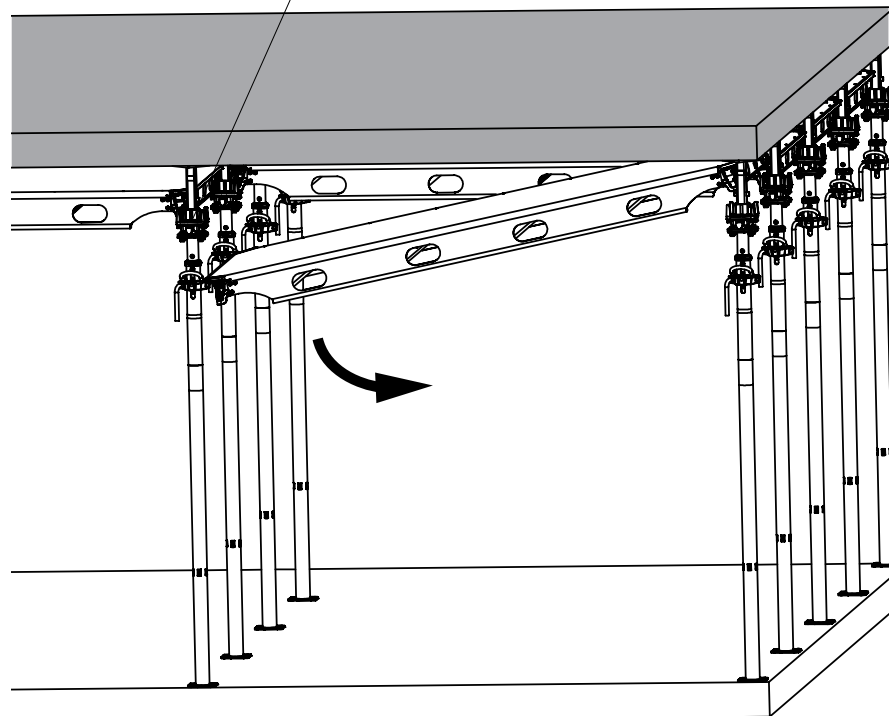
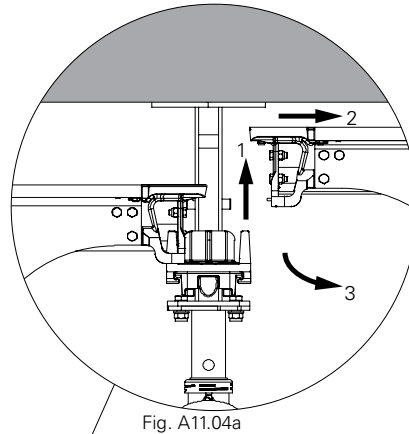

Fig. A11.04

Removing the panels in shorter direction

1. Similarly, to remove the panel in shorter direction, lift the panel from fly-plate pin. (Fig. A11.05)
2. Push the panel aside and then tilt it to lower it to the ground.



Always ensure while tilting and lowering the panel in any direction, it should rotate towards the free end.

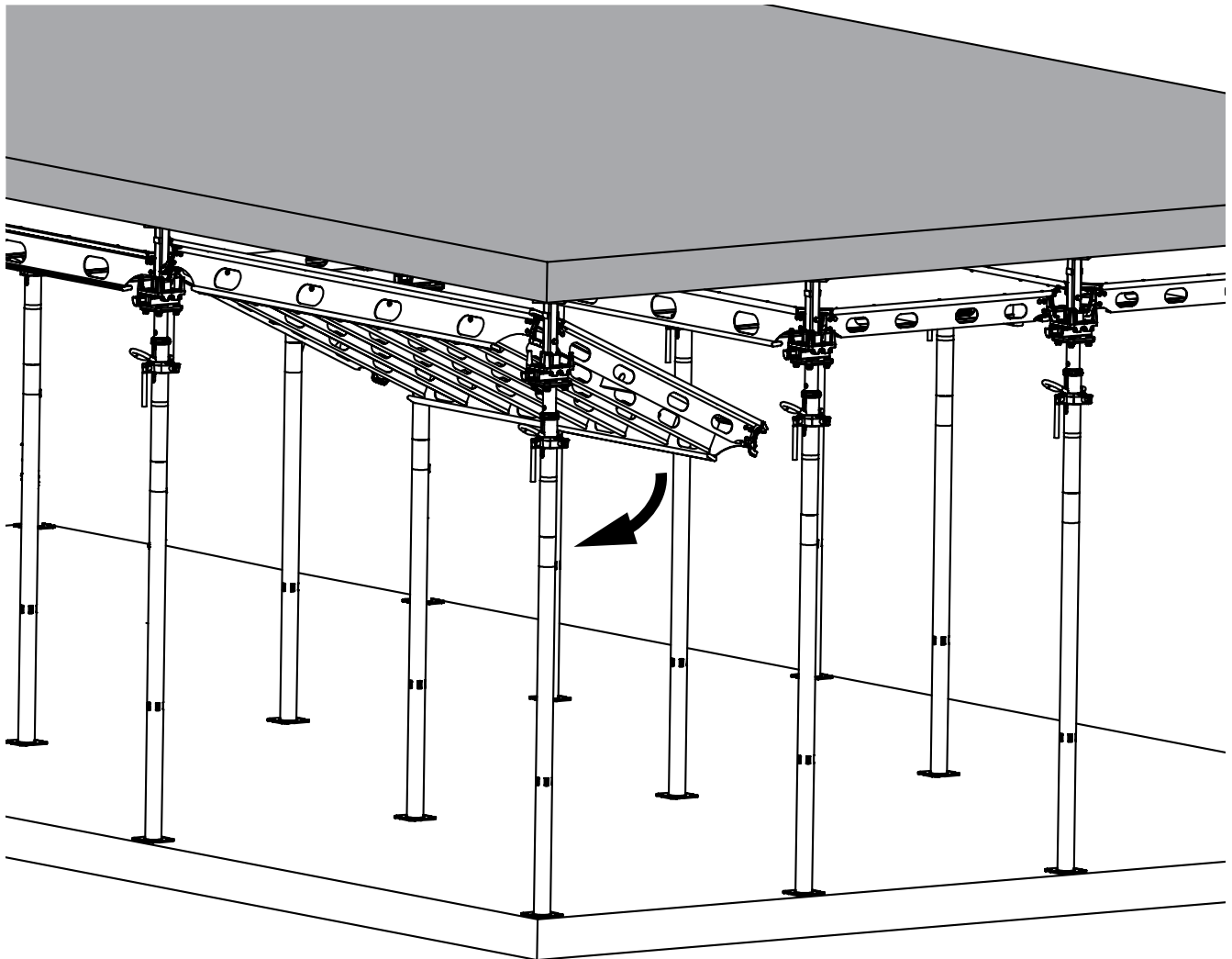

Fig. A11.05

Once all the panels are removed, the prop with dropheads remain undisturbed. (Fig. A11.06)

After reaching the required concrete strength

- Remove the prop with dropheads and store in pallets.

Cleaning

Before next shuttering, clean ALPHADECK components and panel edges and spray once again, e.g. with PERI Bio Clean, see Section "Cleaning and maintenance instructions" on page 8.

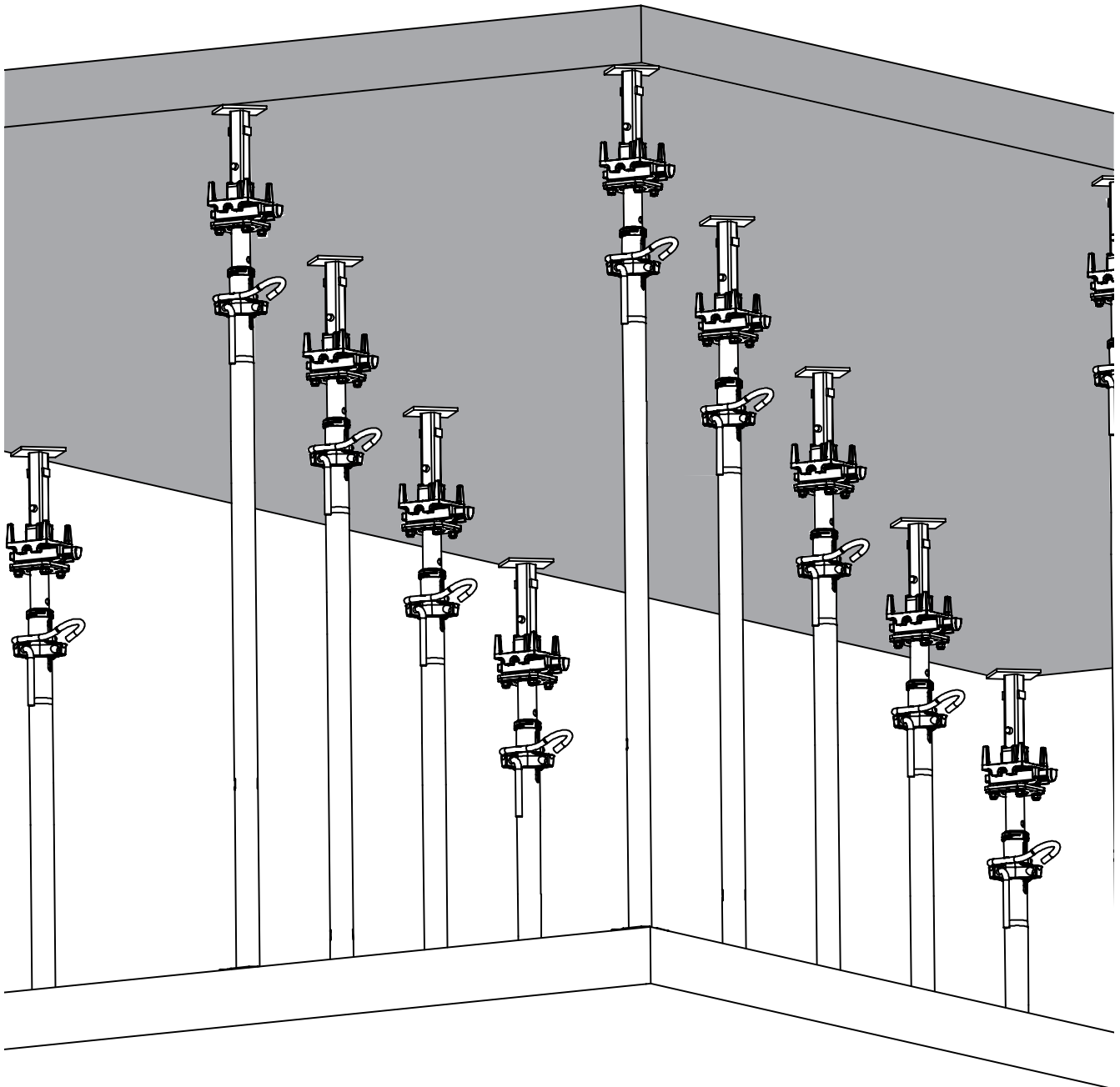

Fig. A11.06

When early striking is not required



Warning

Risk of collapse!

⇒ Deshuttering to start only when the concrete has sufficiently hardened and the person in charge has given the go-ahead for striking to take place.



- As a general rule, the striking process should be carried out by reversing the shuttering process.
- Striking is to be carried out by means of a safe mobile scaffold.
- Deshuttering of the system should start from infill areas.

Deshuttering

1. Support the panel edge at the middle using two shuttering aids (**6**) and (**6a**) in the shorter direction for the first two bays. (Fig. A11.07)
 - Secure shuttering aids so they cannot be knocked over.
2. Lower two props at rear side of the first panel by 2 cm followed by front props.
 - Do not lower slab props too far or the panels will no longer hold them in place and they will become unstable.
3. Remove the outside prop (**3**) keeping the shuttering aid (**6**), (**6a**) in position.
 - Always secure panels that are not held in place by four slab props with a shuttering aid. (Fig. A11.07)
4. Swivel down the first panel using shuttering aid and then remove the panel.
5. Repeat this process to complete the deshuttering.

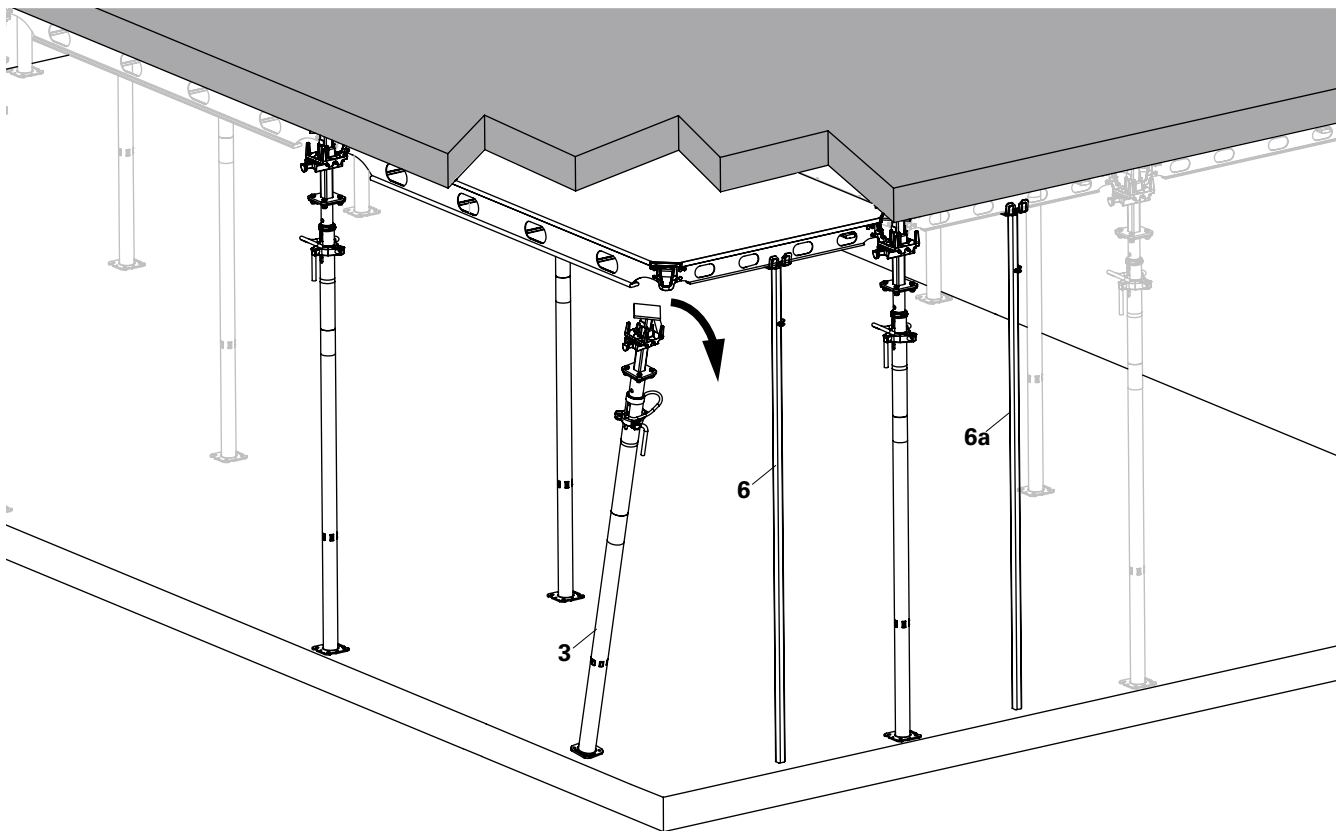

Fig. A11.07

Stripping tool AD

The stripping tool AD (**26**) has been developed to facilitate easy deshuttering of AD panels.

During the striking process, the panels can become stuck to the concreted slab. If the panel cannot be released using its weight force alone, use stripping tool AD (**26**) to release the panel ADP.

It engages with the ADP panel frames (edge rail A or edge rail B), providing a lever that will remove the panel from the concreted slab.

It can also be used to lower flyplate of the drophead ADH and filler beam ADF whenever it gets stuck post concreting.

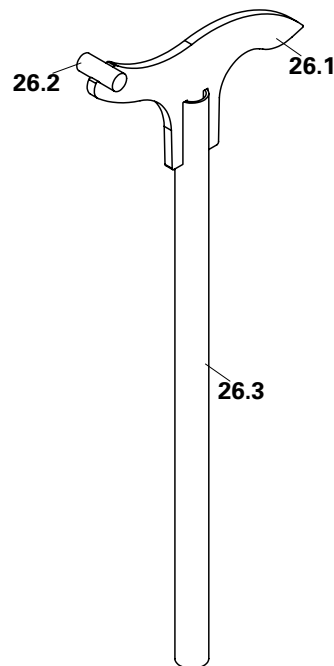

Fig. A11.08

Components

26 Stripping tool

26.1 Head

26.2 Pivot rod

26.3 Handle

Detaching the panel ADP

1. While using the stripping tool for lowering the panels, ensure that the front face (**26a**) of head is placed onto the bottom of the edge rail A or edge rail B profile and the pivot rod (**26.2**) is pressed to the slab surface. (Fig. A11.09a + Fig. A11.10a)
2. Apply upward force using the handle (**26.3**) of stripping tool AD (**26**) such that pivot rod (**26.2**) is pressed against the slab surface. (Fig. A11.09a + Fig. A11.10a)
This helps in detaching the panel from the slab surface.



The stripping tool AD (**26**) should always be used on the bottom of edge rail A or edge rail B profile of the panel. (Fig. A11.09a)



Do not use the stripping tool AD (**26**) on the panel slots.

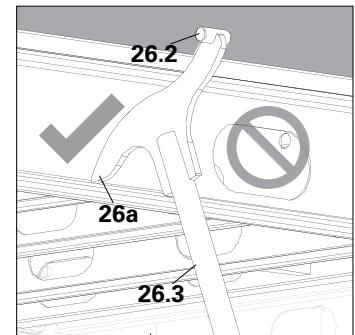

Fig. A11.09a

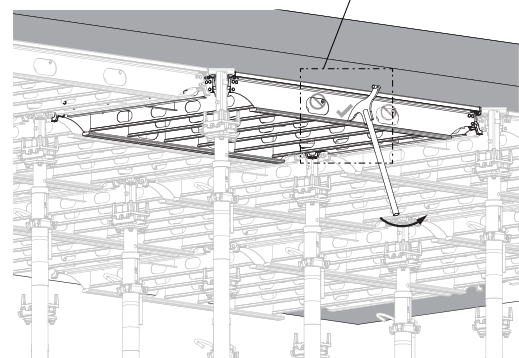

Fig. A11.09

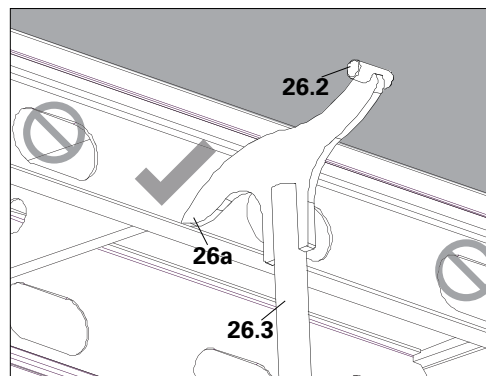

Fig. A11.10a

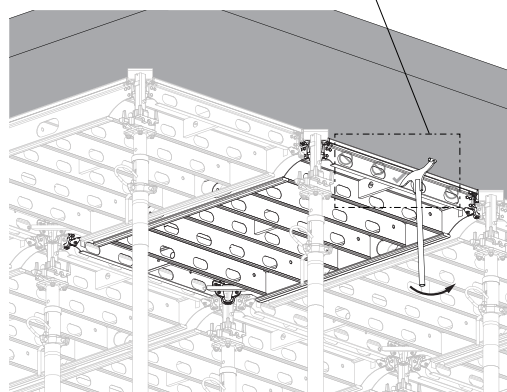

Fig. A11.10

Detaching the filler beam ADF

1. While using the stripping tool AD (26) for lowering the filler beam ADF (8), ensure that the front face (26a) of the head is placed on the lip of the filler beam and the pivot rod (26.2) is pressed against the slab surface. (Fig. A11.11 + Fig. A11.12)
2. Apply upward force using the handle (26.3) of stripping tool AD (26) such that pivot rod (26.2) is pressed against the slab surface. (Fig. A11.12) This helps in detaching the filler beam ADF (8) from the slab surface.

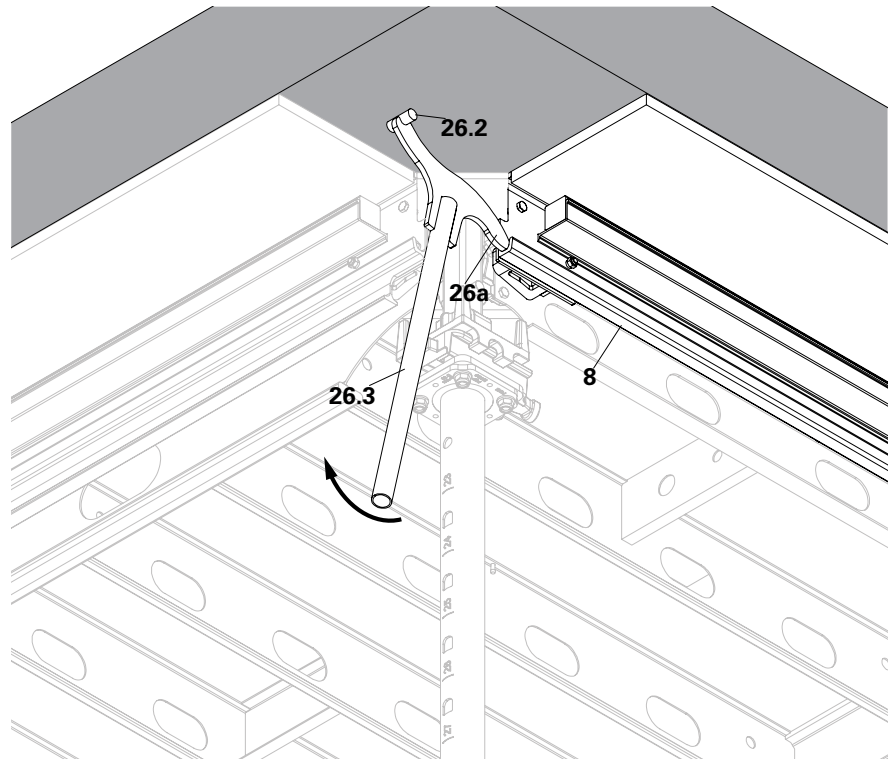

Fig. A11.11

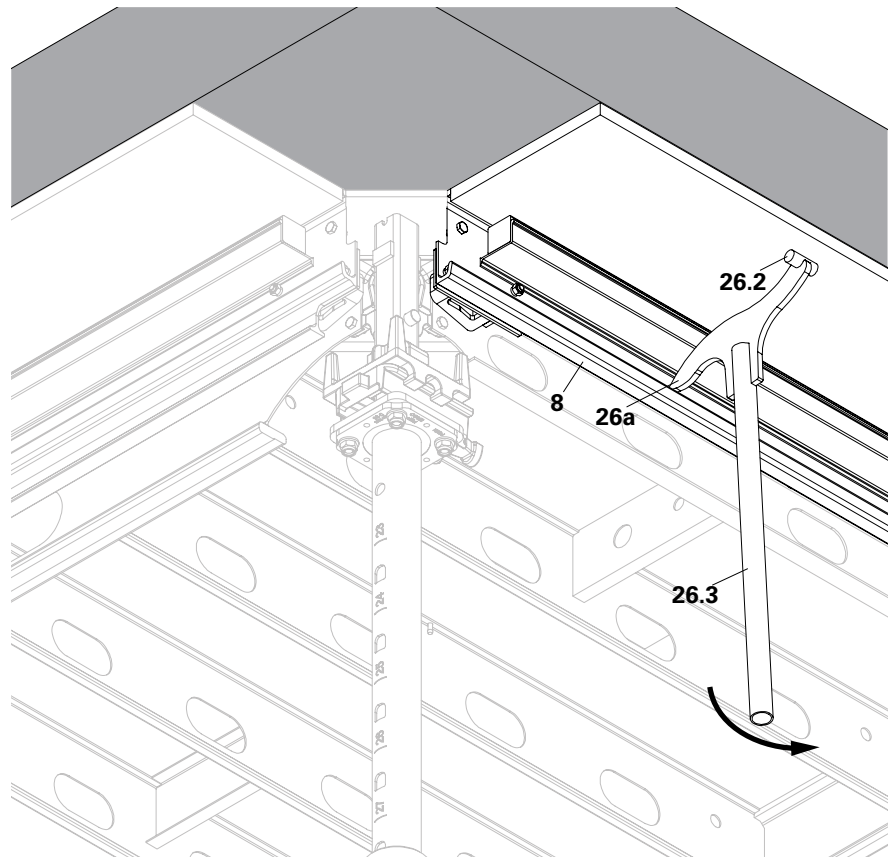

Fig. A11.12

Detaching the flyplate of the drophead ADH

1. While using the stripping tool for lowering the flyplate of the drophead ADH (**2**) ensure that the front face (**26a**) of head is placed in the gap between the flyplate pins and the pivot rod (**26.2**) is pressed at the top against the panel joint. (Fig. A11.13)
2. Apply upward force using the handle (**26.3**) of stripping tool AD (**26**) such that pivot rod (**26.2**) is pressed against the slab surface. (Fig. A11.13a)

This helps in lowering the flyplate of the drophead (**2**) whenever it gets stuck post concreting.

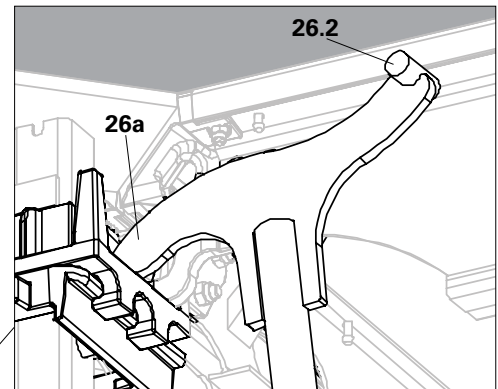

Fig. A11.13a

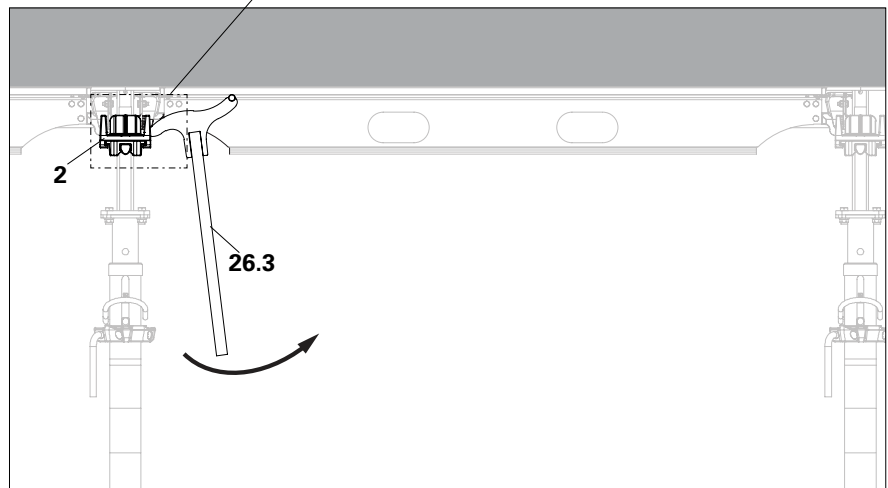

Fig. A11.13

Striking guide values

Panel ADP 240 x 120 Panel ADP 180 x 120	
Upto slab thickness d [mm]	Required concrete strength $f_{ck,cube}$ [N/mm ²]
150	15
175	13
200	9
225	8
250	7
275	7
300	7
350	7
400–550*	7

Tab. A11.01

* Applicable only for the panel ADP 180 x 120



The required concrete strength at the time of striking is decisive. This is to be calculated using suitable methods.

- The required class of reinforced concrete is minimum C20/25.
- At least 1.88 cm²/m in both direction (e.g. Q 188) is necessary for the bottom reinforcement layer.
- A live load of 1.50 kN/m² is factored in for the early-struck slab.
- It is necessary to consider the loads from concreting of upper slabs into account while selecting the props.

B1 Load charts for slab props

PEP 20



Permissible prop load [kN]

Extension length [m]	PEP 20 N 260*		PEP 20-300		PEP 20-350		PEP 20-400		PEP 20-500	
	L = 1.51 – 2.60 m		L = 1.71 – 3.00 m		L = 1.96 – 3.50 m		L = 2.21 – 4.00 m		L = 2.71 – 5.00 m	
	Outer tube bottom	Inner tube bottom	Outer tube bottom	Inner tube bottom	Outer tube bottom	Inner tube bottom	Outer tube bottom	Inner tube bottom	Outer tube bottom	Inner tube bottom
1.60	35.0	35.0								
1.70	35.0	35.0								
1.80	35.0	35.0	36.4	36.4						
1.90	35.0	35.0	36.4	36.4						
2.00	33.5	35.0	36.1	36.4	36.4	36.4				
2.10	31.9	35.0	33.2	36.4	36.4	36.4				
2.20	30.9	35.0	31.4	36.4	36.4	36.4				
2.30	29.8	35.0	29.9	36.4	36.4	36.4	36.4	36.4		
2.40	28.6	35.0	28.7	36.4	36.4	36.4	36.4	36.4		
2.50	27.1	32.1	27.7	36.4	36.4	36.4	36.4	36.4		
2.60	24.8	29.4	26.9	34.7	34.8	36.4	36.4	36.4		
2.70			25.7	31.7	33.4	36.4	36.4	36.4		
2.80			24.0	28.9	32.1	36.4	36.4	36.4	36.4	36.4
2.90			22.3	26.5	31.1	36.4	36.4	36.4	36.4	36.4
3.00			20.5	23.9	30.1	36.4	36.4	36.4	36.4	36.4
3.10					28.3	35.7	34.6	36.4	36.4	36.4
3.20					26.5	32.5	33.5	36.4	36.4	36.4
3.30					24.8	29.7	32.1	36.4	36.4	36.4
3.40					23.1	27.2	30.5	36.4	36.4	36.4
3.50					21.3	24.4	28.7	34.9	36.4	36.4
3.60							26.9	32.1	36.4	36.4
3.70							25.3	29.8	36.4	36.4
3.80							23.7	27.6	36.4	36.4
3.90							22.3	25.5	36.4	36.4
4.00							20.7	23.5	35.3	36.4
4.10									33.3	36.4
4.20									31.5	36.4
4.30									29.8	35.0
4.40									28.2	32.9
4.50									26.8	30.8
4.60									25.3	28.9
4.70									24.1	27.2
4.80									22.8	25.7
4.90									21.5	24.1
5.00									20.3	22.1

All PEP 20 Props correspond to Class D of DIN EN 1065, i. e. the permissible prop load for all extension lengths is a minimum of 20 kN.

*For the N Props, use of the inner tube at the bottom is only possible in connection with PERI Slab Tables

B1 Load charts for slab props

PEP 30



Permissible prop load [kN]

Extension length [m]	PEP 30-150 L = 0.96 – 1.50 m		PEP 30-250 L = 1.46 – 2.50 m		PEP 30-300 L = 1.71 – 3.00 m		PEP 30-350 L = 1.96 – 3.50 m		PEP 30-400 L = 2.21 – 4.00 m	
	Outer tube bottom	Inner tube bottom	Outer tube bottom	Inner tube bottom	Outer tube bottom	Inner tube bottom	Outer tube bottom	Inner tube bottom	Outer tube bottom	Inner tube bottom
1.00	36.4	36.4								
1.10	36.4	36.4								
1.20	36.4	36.4								
1.30	35.9	36.4								
1.40	35.3	36.4								
1.50	34.5	36.4	42.9	42.9						
1.60			42.9	42.9						
1.70			42.9	42.9						
1.80			42.1	42.9	42.9	42.9				
1.90			39.7	42.9	42.9	42.9				
2.00			37.9	42.9	42.9	42.9	45.5	45.5		
2.10			36.4	42.9	42.9	42.9	45.5	45.5		
2.20			35.5	42.9	42.9	42.9	45.5	45.5		
2.30			34.3	41.5	42.9	42.9	45.5	45.5	41.5	41.5
2.40			33.1	38.7	42.7	42.9	45.5	45.5	41.5	41.5
2.50			31.0	35.9	41.1	42.9	45.5	45.5	41.5	41.5
2.60					40.0	42.9	45.5	45.5	41.5	41.5
2.70					38.5	42.9	45.5	45.5	41.5	41.5
2.80					36.9	41.6	45.5	45.5	41.5	41.5
2.90					34.2	38.3	45.0	45.5	41.5	41.5
3.00					31.3	34.8	43.6	45.5	41.5	41.5
3.10							41.4	44.2	41.5	41.5
3.20							38.7	42.1	41.5	41.5
3.30							36.1	38.7	41.5	41.5
3.40							33.3	35.7	41.5	41.5
3.50							30.7	32.5	41.5	41.5
3.60									41.5	41.5
3.70									41.3	41.5
3.80									38.5	41.3
3.90									35.9	38.1
4.00									33.2	34.7

All PEP 30 Props correspond to Class E of DIN EN 1065, i. e. the permissible prop load for all extension lengths is a minimum of 30 kN.

B1 Load charts for slab props

PEP Ergo B



Permissible prop load [kN]

Extension length [m]	PEP Ergo B-300		PEP Ergo B-350	
	L = 1.97 – 3.00 m		L = 2.25 – 3.50 m	
	Outer tube bottom	Inner tube bottom	Outer tube bottom	Inner tube bottom
2.00	30.8	30.8		
2.10	29.8	30.8		
2.20	27.0	30.8		
2.30	24.6	30.8	30.8	28.6
2.40	23.0	30.8	28.6	28.6
2.50	21.5	30.8	25.5	28.6
2.60	20.3	29.5	23.1	28.4
2.70	19.3	27.5	21.3	28.0
2.80	18.3	24.4	19.8	27.4
2.90	16.9	22.3	18.6	26.1
3.00	15.6	19.9	17.5	24.4
3.10			16.3	22.8
3.20			15.2	20.8
3.30			14.3	19.0
3.40			13.2	17.4
3.50			12.4	15.7



- PERI PEP Ergo B-300 and PEP Ergo B-350 Props meet the load-bearing capacity requirements of Prop Class B as stipulated in DIN EN 1065.
- General Building Inspectorate Approval Z-8.311-934 issued by the German Institute for Building Technology.

B1 Load charts for slab props

PEP Ergo D

Permissible prop load [kN]

Extension length [m]	PEP Ergo D-150 L = 0.98 – 1.50 m		PEP Ergo D-250 L = 1.47 – 2.50 m		PEP Ergo D-300 + L = 1.79 – 3.00 m	
	Outer tube bottom	Inner tube bottom	Outer tube bottom	Inner tube bottom	Outer tube bottom	Inner tube bottom
	1.00	30.8	30.8			
1.10	30.8	30.8				
1.20	30.8	30.8				
1.30	30.8	30.8				
1.40	28.5	30.8				
1.50	26.4	30.8	35.0	35.0		
1.60			35.0	35.0		
1.70			32.9	35.0		
1.80			30.7	35.0	35.0	35.0
1.90			29.1	35.0	35.0	35.0
2.00			28.1	35.0	35.0	35.0
2.10			27.3	35.0	35.0	35.0
2.20			26.5	34.1	35.0	35.0
2.30			25.7	31.7	33.4	35.0
2.40			24.3	28.5	31.7	34.0
2.50			22.4	26.3	30.1	32.7
2.60					28.3	31.3
2.70					26.2	29.1
2.80					24.3	26.9
2.90					22.4	24.9
3.00					20.6	22.8



- PERI PEP Ergo D-150, PEP Ergo D-250, PEP Ergo D-300 + Props fulfil Prop Class D load-bearing capacity requirements of DIN EN 1065.
- In addition, Prop PEP Ergo D-250 fulfils the Prop Class B requirements as stipulated in DIN EN 1065.
- General Building Inspectorate Approval Z-8.311-934 for PERI PEP Ergo D-150, PEP Ergo D-250 and PEP Ergo D-300 +.

B1 Load charts for slab props

PEP Ergo D



Permissible prop load [kN]

Extension length [m]	PEP Ergo D-350 + L = 2.08 – 3.50 m		PEP Ergo D-400 L = 2.51 – 4.00 m		PEP Ergo D-500 L = 3.26 – 5.00 m	
	Outer tube bottom	Inner tube bottom	Outer tube bottom	Inner tube bottom	Outer tube bottom	Inner tube bottom
2.10	40.0	40.0				
2.20	40.0	40.0				
2.30	40.0	40.0				
2.40	39.7	40.0				
2.50	36.9	40.0				
2.60	34.7	40.0				
2.70	32.9	40.0	40.0	40.0		
2.80	31.6	40.0	40.0	40.0		
2.90	30.3	40.0	40.0	40.0		
3.00	29.2	39.1	40.0	40.0		
3.10	27.2	35.4	37.7	40.0		
3.20	25.4	32.1	35.7	40.0		
3.30	23.7	29.4	33.9	40.0	40.0	40.0
3.40	22.1	27.0	32.5	40.0	40.0	40.0
3.50	20.7	24.4	31.0	39.7	40.0	40.0
3.60			29.0	36.4	40.0	40.0
3.70			27.0	33.3	40.0	40.0
3.80			25.2	30.7	40.0	40.0
3.90			23.5	28.2	40.0	40.0
4.00			21.8	26.0	40.0	40.0
4.10					39.3	40.0
4.20					36.5	40.0
4.30					34.0	39.2
4.40					31.8	37.0
4.50					29.9	34.6
4.60					28.1	32.4
4.70					26.4	30.4
4.80					24.8	28.5
4.90					23.4	26.8
5.00					21.8	25.3



- PERI PEP Ergo D-350 +, PEP Ergo D-400 and PEP Ergo D-500 Props fulfil Prop Class D load-bearing capacity requirements of DIN EN 1065.
- General Building Inspectorate Approval Z-8.311-941 for PERI PEP Ergo D-350 +, PEP Ergo D-400 and PEP Ergo D-500.

B1 Load charts for slab props

PEP Ergo D

Permissible prop load [kN]

Extension length [m]	PEP Ergo E-300 + L = 1.79 – 3.00 m		PEP Ergo E-350 + L = 2.08 – 3.50 m		PEP Ergo E-400 L = 2.51 – 4.00 m	
	Outer tube bottom	Inner tube bottom	Outer tube bottom	Inner tube bottom	Outer tube bottom	Inner tube bottom
1.80	50.4	50.4				
1.90	50.4	50.4				
2.00	50.4	50.4				
2.10	50.4	50.4	50.4	50.4		
2.20	50.4	50.4	50.4	50.4		
2.30	50.4	50.4	50.4	50.4		
2.40	47.3	50.4	50.4	50.4		
2.50	45.6	50.4	50.4	50.4		
2.60	44.5	50.4	50.4	50.4	50.4	50.4
2.70	43.3	50.4	48.5	50.4	50.4	50.4
2.80	41.8	50.4	46.4	50.4	50.4	50.4
2.90	40.3	48.0	44.5	50.4	50.4	50.4
3.00	37.5	43.0	43.0	50.4	50.4	50.4
3.10			41.5	50.4	50.4	50.4
3.20			38.7	46.1	50.4	50.4
3.30			36.0	41.9	50.4	50.4
3.40			33.3	38.2	50.4	50.4
3.50			30.9	34.7	48.5	50.4
3.60					46.0	50.4
3.70					42.7	48.4
3.80					39.7	44.7
3.90					36.9	41.1
4.00					34.1	37.7



- PERI Props PEP Ergo E-300 +, PEP Ergo E-350 + and PEP Ergo E-400 fulfil the Prop Class E load-bearing capacity requirements of DIN EN 1065.
- General Building Inspectorate Approval Z-8.311-941 of the German Institute for Building Technology.

B1 Load charts for slab props

MULTIPROP 250, 350, 480, 625



Permissible prop load [kN]

Extension length [m]	MP 250 L = 1.45 – 2.50 m		MP 350 L = 1.95 – 3.50 m		MP 480 L = 2.60 – 4.80 m		MP 625 L = 4.30 – 6.25 m	
	Outer tube bottom	Inner tube bottom	Outer tube bottom	Inner tube bottom	Outer tube bottom	Inner tube bottom	Outer tube bottom	Inner tube bottom
1.45	75.5	78.5						
1.50	75.5	78.5						
1.60	75.5	78.5						
1.70	75.5	78.5						
1.80	73.8	78.5						
1.90	70.6	78.5						
1.95	68.0	78.5	91.0	90.1				
2.00	67.3	78.5	91.0	90.1				
2.10	65.7	76.8	86.0	90.1				
2.20	64.1	75.1	80.6	90.1				
2.30	62.5	72.6	75.1	89.8				
2.40	60.8	69.1	70.7	87.9				
2.50	59.2	65.6	66.4	86.1				
2.60			63.7	83.1	88.5	73.6		
2.70			61.1	80.1	83.7	73.3		
2.80			59.2	77.1	78.8	72.9		
2.90			57.4	74.1	74.0	72.6		
3.00			56.0	70.3	69.1	72.2		
3.10			54.5	66.6	64.9	71.4		
3.20			52.9	61.8	60.7	70.7		
3.30			51.3	57.1	56.5	70.0		
3.40			47.7	51.7	54.1	68.2		
3.50			44.2	46.4	51.8	66.5		
3.60					49.4	64.7		
3.70					47.5	60.4		
3.80					45.7	56.1		
3.90					43.8	51.8		
4.00					41.8	48.4		
4.10					39.7	45.0		
4.20					37.7	41.6		
4.30					35.8	39.3	57.9	45.7
4.40					33.9	37.0	56.3	45.7
4.50					32.0	34.8	54.7	45.7
4.60					30.2	32.5	52.5	45.1
4.70					28.3	30.2	50.3	44.4
4.80					26.4	27.9	47.9	43.5
4.90							45.2	42.4
5.00							42.5	41.3
5.10							39.9	39.9
5.20							37.2	38.5
5.30							34.9	37.1
5.40							32.8	35.6
5.50							30.8	34.1
5.60							29.3	32.6
5.70							27.8	31.2
5.80							26.4	29.6
5.90							25.1	27.9
6.00							23.8	26.2
6.10							22.7	24.8
6.20							21.6	23.4
6.25							21.0	22.7

MULTIPROP Props are classified according to official approval as follows:

MP 250 Class T 25	MP 480 Class D 45
MP 350 Class R 35	MP 625 Class D 60

B1 Load charts for slab props

PEP Alpha, PEP Alpha-2

Permissible prop load [kN]

Extension length [m]	PEP Alpha		PEP Alpha-2			
	B-300	B-350	B-300		B-350	
	Outer tube or inner tube bottom	Outer tube or inner tube bottom	Outer tube bottom	Inner tube bottom	Outer tube bottom	Inner tube bottom
1.70						
1.80	30.0		32.4	32.4		
1.90	30.0		31.7	32.4		
2.00	30.0		30.4	32.4	34.9	34.9
2.10	27.2	30.0	27.9	32.4	33.2	34.9
2.20	24.9	28.9	25.5	32.4	30.1	34.9
2.30	22.6	26.4	23.4	32.4	27.3	34.9
2.40	20.8	24.3	22.6	32.4	25.0	34.9
2.50	19.2	22.4	21.7	30.5	23.3	34.9
2.60	17.7	20.7	20.4	27.2	22.1	34.7
2.70	16.4	19.2	19.0	24.6	21.1	31.5
2.80	15.3	17.8	17.8	22.4	19.7	28.1
2.90	14.2	16.6	16.7	20.7	18.5	25.3
3.00	13.3	15.5	15.5	18.9	17.4	23.1
3.10		14.5			16.5	21.3
3.20		13.6			15.5	19.6
3.30		12.8			14.6	17.7
3.40		12.1			13.3	15.8
3.50		11.4			12.1	14.3

Extension length [m]	PEP Alpha				PEP Alpha-2			
	D-300		D-350		D-300		D-350	
	Outer tube bottom	Inner tube bottom	Outer tube bottom	Inner tube bottom	Outer tube bottom	Inner tube bottom	Outer tube bottom	Inner tube bottom
1.70	36.1	36.1						
1.80	36.1	36.1			36.1	36.1		
1.90	36.1	36.1			36.1	36.1		
2.00	36.1	36.1	36.1	36.1	36.1	36.1	36.1	36.1
2.10	35.6	36.1	36.1	36.1	36.0	36.1	36.1	36.1
2.20	33.8	36.1	36.1	36.1	33.8	36.1	36.1	36.1
2.30	32.1	36.1	36.1	36.1	32.1	36.1	36.1	36.1
2.40	30.9	36.1	36.1	36.1	30.9	36.1	36.1	36.1
2.50	29.7	35.2	36.1	36.1	29.7	36.1	36.1	36.1
2.60	27.5	33.2	35.6	36.1	27.5	34.3	35.7	36.1
2.70	25.5	30.6	33.9	36.1	25.5	30.9	34.3	36.1
2.80	23.6	28.1	32.7	36.1	23.6	28.1	32.9	36.1
2.90	21.9	25.8	31.2	36.1	21.9	25.8	31.8	36.1
3.00	20.6	23.5	29.1	36.1	20.6	23.5	29.8	36.1
3.10			27.3	34.2			27.9	34.3
3.20			25.5	31.4			26.1	31.7
3.30			23.7	28.7			24.4	28.8
3.40			22.1	26.3			22.7	26.5
3.50			20.6	24.2			21.1	24.3



- The props fulfil the load-bearing capacity requirements of DIN EN 1065.

ALPHADECK Panel Slab Formwork



Article no. Weight kg

135243	49.00
135178	38.10

Panel ADP

Panel ADP 240 x 120

Panel ADP 180 x 120

powder coated aluminium frame with 9 mm thick birch ply as formlining.

L	B
2400	1200
1800	1200

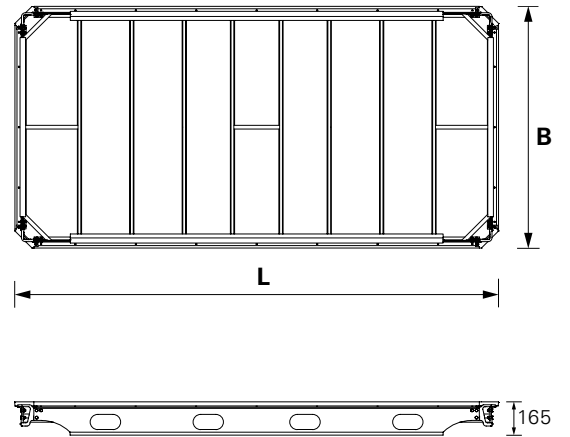
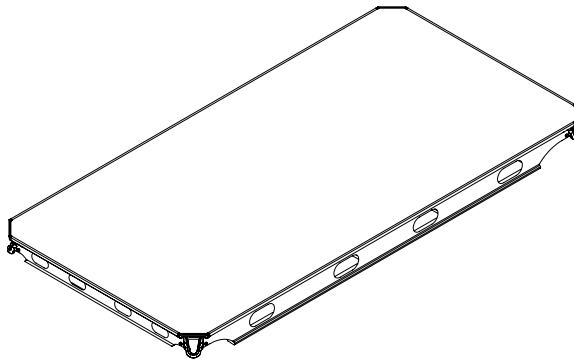

134689	7.02
--------	------

Drophead ADH

Lowering height 12 cm. Only one type of head serves all requirements.

Complete with

- 4 pc. 710224 Bolt M12 x 40, grade 8.8 (ISO 4017)
- 4 pc. 710330 Nut M12, grade 8 (ISO 4032)
- 4 pc. 780702 Washer M12, 200HV (ISO 7089)

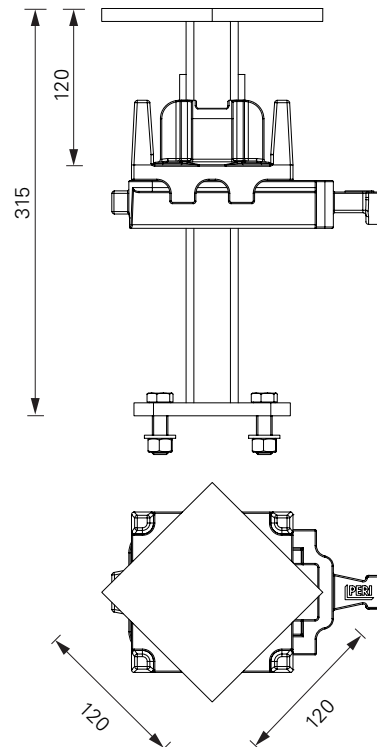
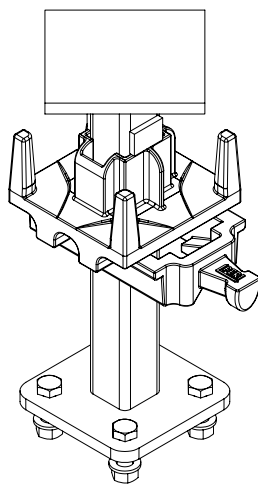

Article no. Weight kg

135675	13.30
135671	10.40

Filler Beam ADF
Filler Beam ADF 240
Filler Beam ADF 180

For filler areas.
 'Timber insert' not included.

L
2400
1800

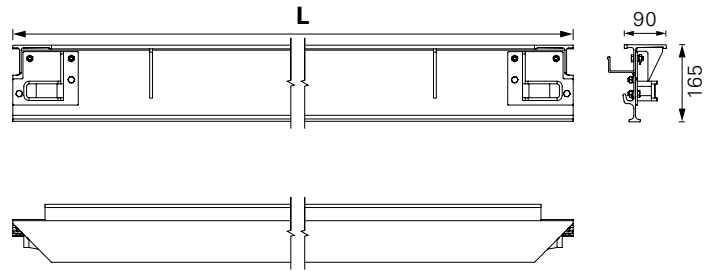
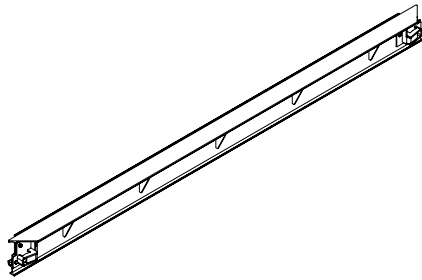

135667	6.60
--------	------

Filler Beam ADF 120

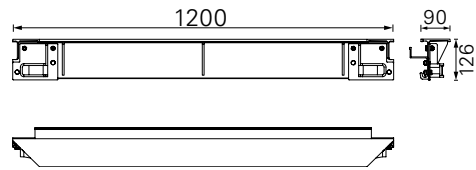
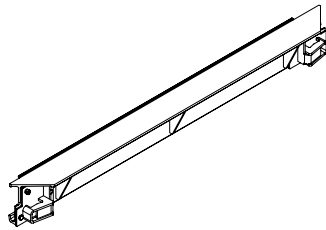

138548	19.10
138547	14.80

Filler beam ADF with ADF-P nailing insert

Filler beam ADF-P 240
Filler beam ADF-P 180

For filler areas.

L	Complete with
2400	4 pc. 138545 ADF-P nailing insert (56 cm) 8 pc. 024540 TSS-Torx 6 x 40, galv.
L	Complete with
1800	3 pc. 138545 ADF-P nailing insert (56 cm) 6 pc. 024540 TSS-Torx 6 x 40, galv.

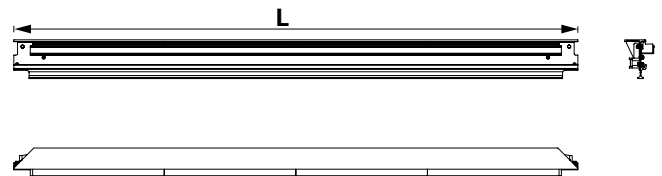
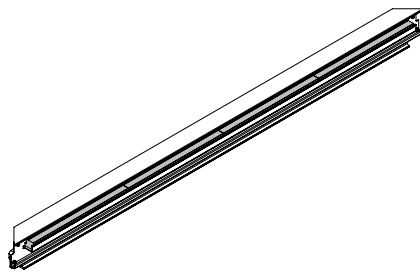

138546	9.36
--------	------

Filler beam ADF-P 120

Complete with

2 pc. 138544 ADF-P nailing insert (53 cm)
 2 pc. 024540 TSS-Torx 6 x 40, galv.

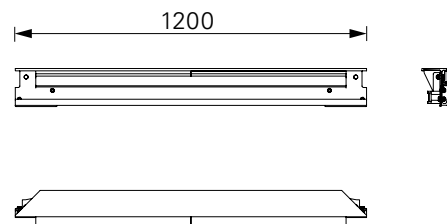
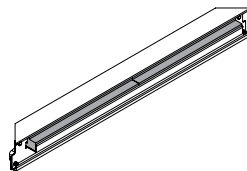

Article no. Weight kg

138544	1.37	ADF-P Nailing Insert L=53
138545	1.45	ADF-P Nailing Insert L=56

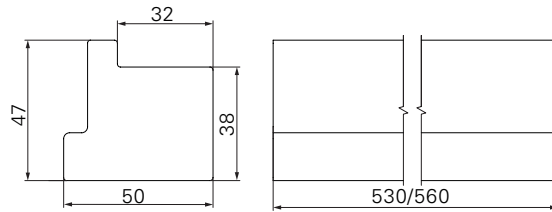
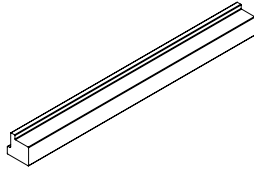

137292 0.18 **Corner Insert AD**

Made of polymer and is used to convert a chamfered corner of ALPHADECK corner into a right-angle corner.

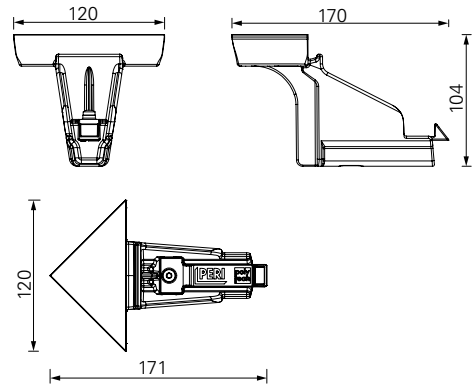
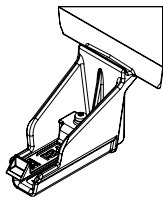

135685 1.59 **Cross Beam Head ADI**
For infill areas

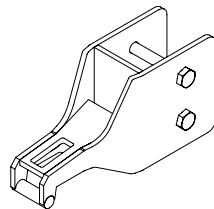

Complete with
2 pc.710593 Bolt M10 x 80
2 pc.710234 Nut M10

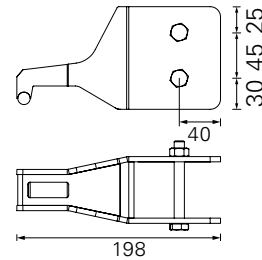

135246 31.30 **Brace ADB**
135245 25.50 **Brace ADB 240**
135244 19.70 **Brace ADB 180**
Brace ADB 120
For stability during erection.

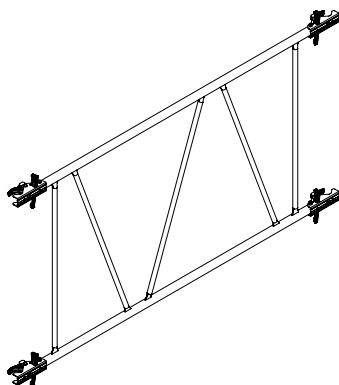

L	B
2400	1200
1800	1200
1200	1200

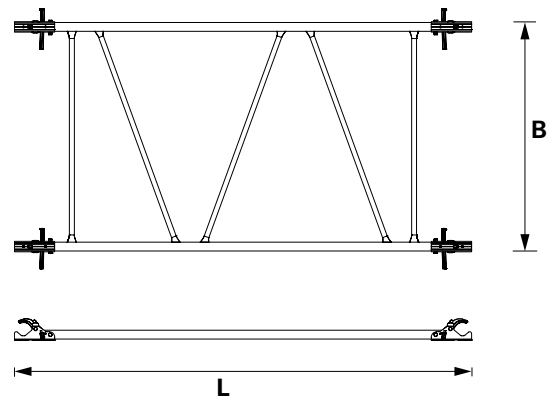

ALPHADECK Panel Slab Formwork



Article no. Weight kg

135605 4.71

Guardrail Post Holder ADG

Guardrail for safe working after shuttering.
Use in combination with Guardrail Post HSGP-2

Complete with

- 1 pc. 018050 Pin \varnothing 16 x 65/86, galv.
- 1 pc. 018060 Cotter Pin 4/1, galv.

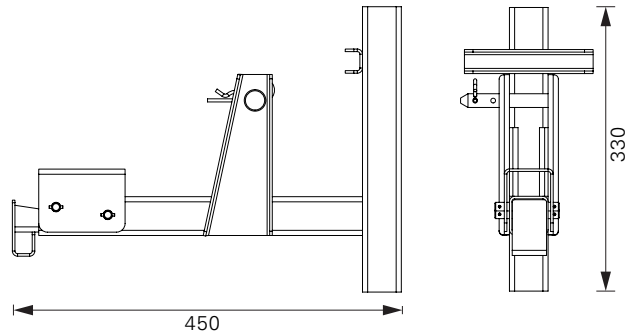
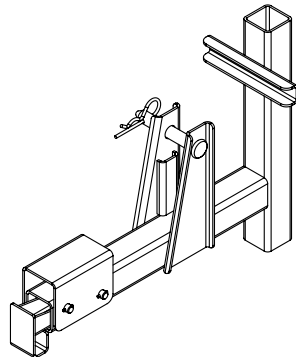

116292 4.72

Guardrail Post HSGP-2

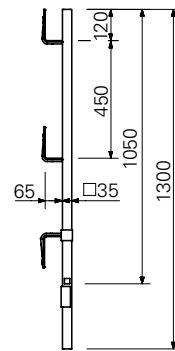

135966 1.45

Stripping tool AD

To facilitate easy deshuttering of AD panels, filler beam ADF and flyplate of the drophead ADH

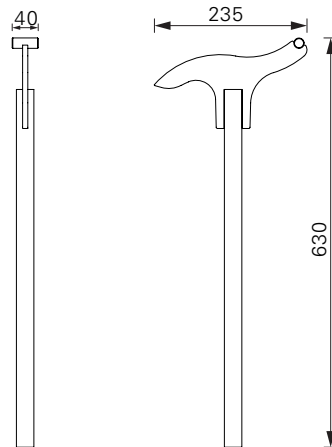
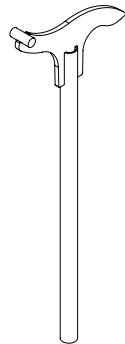

135615 4.16

Shuttering Aid AD

For comfortable and safe shuttering.

Complete with

- 1 pc. 780814 Linch Pin
- 1 pc. 710335 Bolt M10 x 50
- 1 pc. 710234 Nut M10

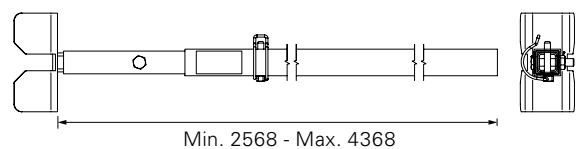
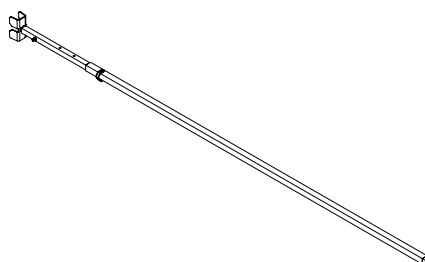

ALPHADECK Panel Slab Formwork



Article no. Weight kg

135713	78.20
135719	70.20

Pallet AD
Pallet AD 240
Pallet AD 180
 For stacking and transportation of
 Panels ADP

Complete with
 4 pc. 710594 Belt Spanner Unit L = 1400 mm
 2 pc. 710595 Belt Lose End L = 4200 mm
 2 pc. 710596 Belt Lose End L = 5000 mm

Note
 Follow Instructions for Use!

Technical Data
 Permissible load-bearing capacity 600 kg.

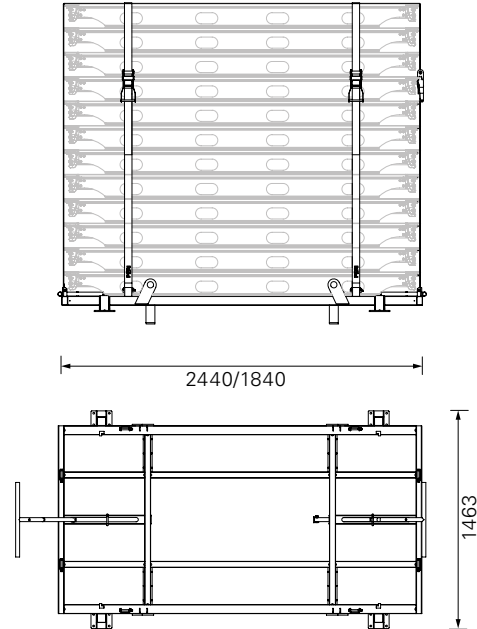
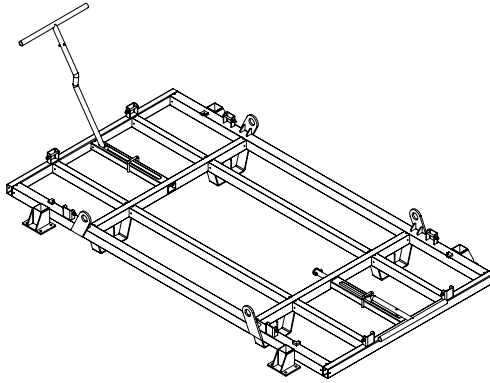

111690 4.14 **Swivel Castor Wheel with Brake**

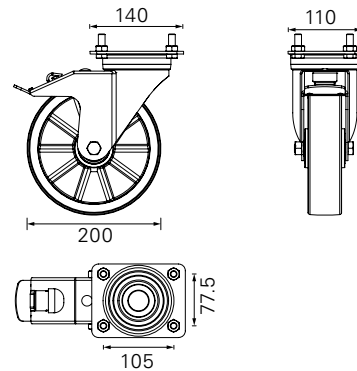
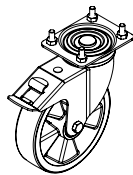

Accessories
Bolt M10 x 30, galv.
Nut M10, galv.

116436	0.03
710234	0.01

136598 0.016 **Stacking Aid AD**
 For stacking the AD panels

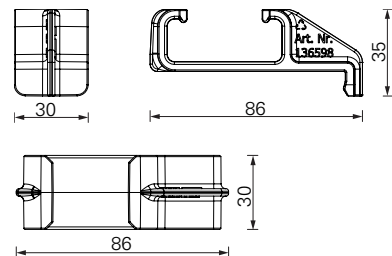
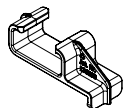

ALPHADECK Panel Slab Formwork



Article no. Weight kg

065016

88.20

Crate Pallet 80 x 120-K, painted

For stacking and transportation of formwork components.

Note

Follow Instructions for Use!

Technical Data

Permissible load-bearing capacity 1.5 t.
Capacity approx. 0.75 m³.

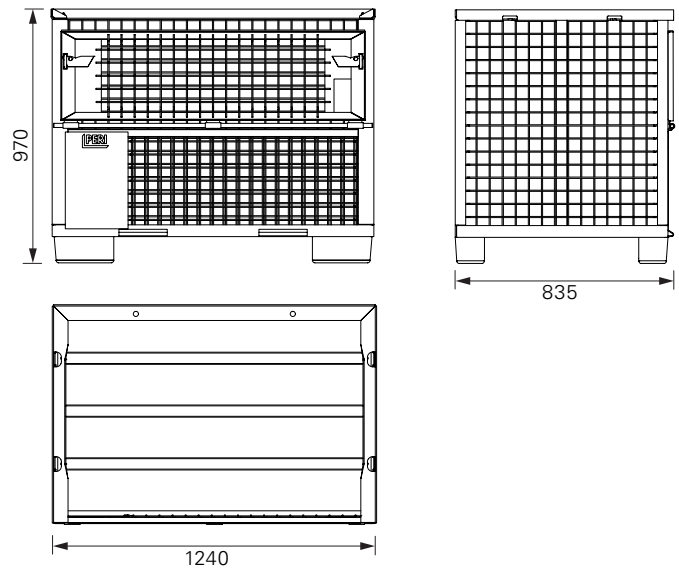
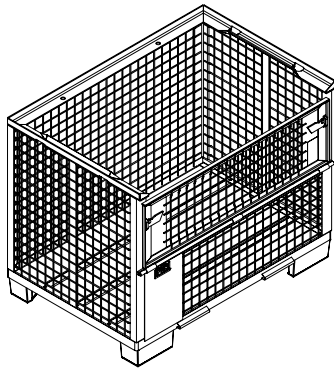

135653

3.29

Crosshead ADC

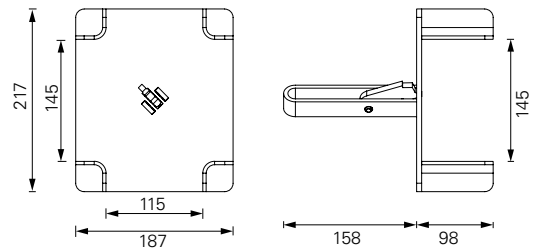
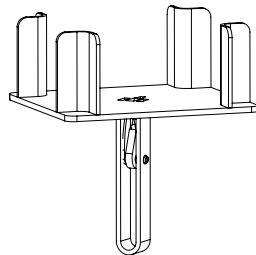

124777

0.21

Anchor Bolt PERI 14/20 x 130

For temporary fixation to reinforced concrete structures.

Note

See PERI data sheet!
Drilling \varnothing 14 mm.

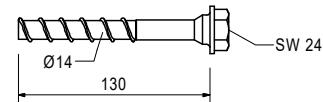
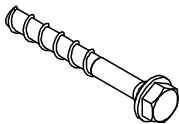

065073

1.37

Anchor Chain 3.0 kN, l = 2.5 m

Technical Data

Permissible tension force 3.0 kN.

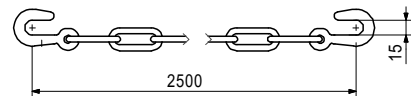
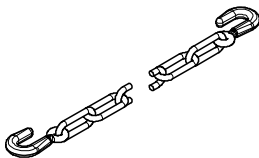

Article no. Weight kg

065074

0.45

Turnbuckle 3.0 kN, M12

Technical Data

Permissible tension force 3.0 kN.

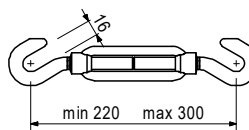
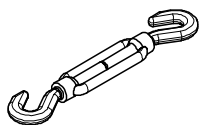

028100

1.83

Base Plate for RS

For securing anchor chains.

Complete with

1 pc. 018050 Pin \varnothing 16 x 65/86, galv.

1 pc. 018060 Cotter Pin 4/1, galv.

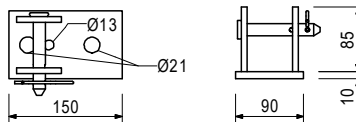
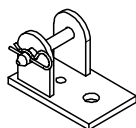

The optimal system for
all projects and every
requirement



Wall formwork



Column formwork



Slab formwork



Climbing systems



Bridge formwork



Tunnel formwork



Shoring



Working scaffolds construction



Working scaffolds facade



Working scaffolds industry



Means of access



Safety scaffolds



Safety systems



System-independent accessories



Services



PERI SE
Formwork Scaffolding Engineering
Rudolf-Diesel-Strasse 19
89264 Weissenhorn
Germany
Telephone +49 (0)7309.950-0
Fax +49 (0)7309.951-0
info@peri.de
www.peri.com

