

VBC Balanced Cantilever Hydraulic System Hydraulic System and Standard Cycle

Assembly Instructions – Version 2.1

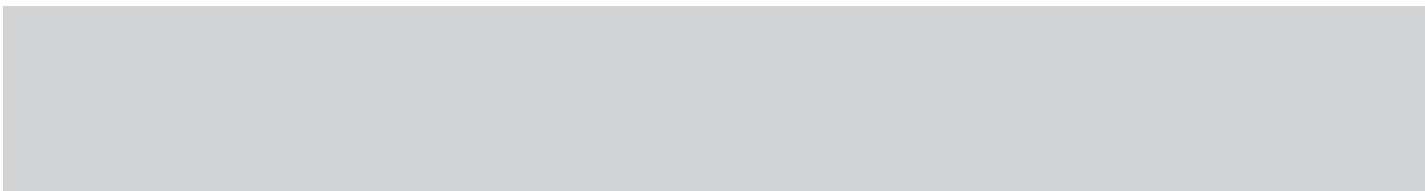
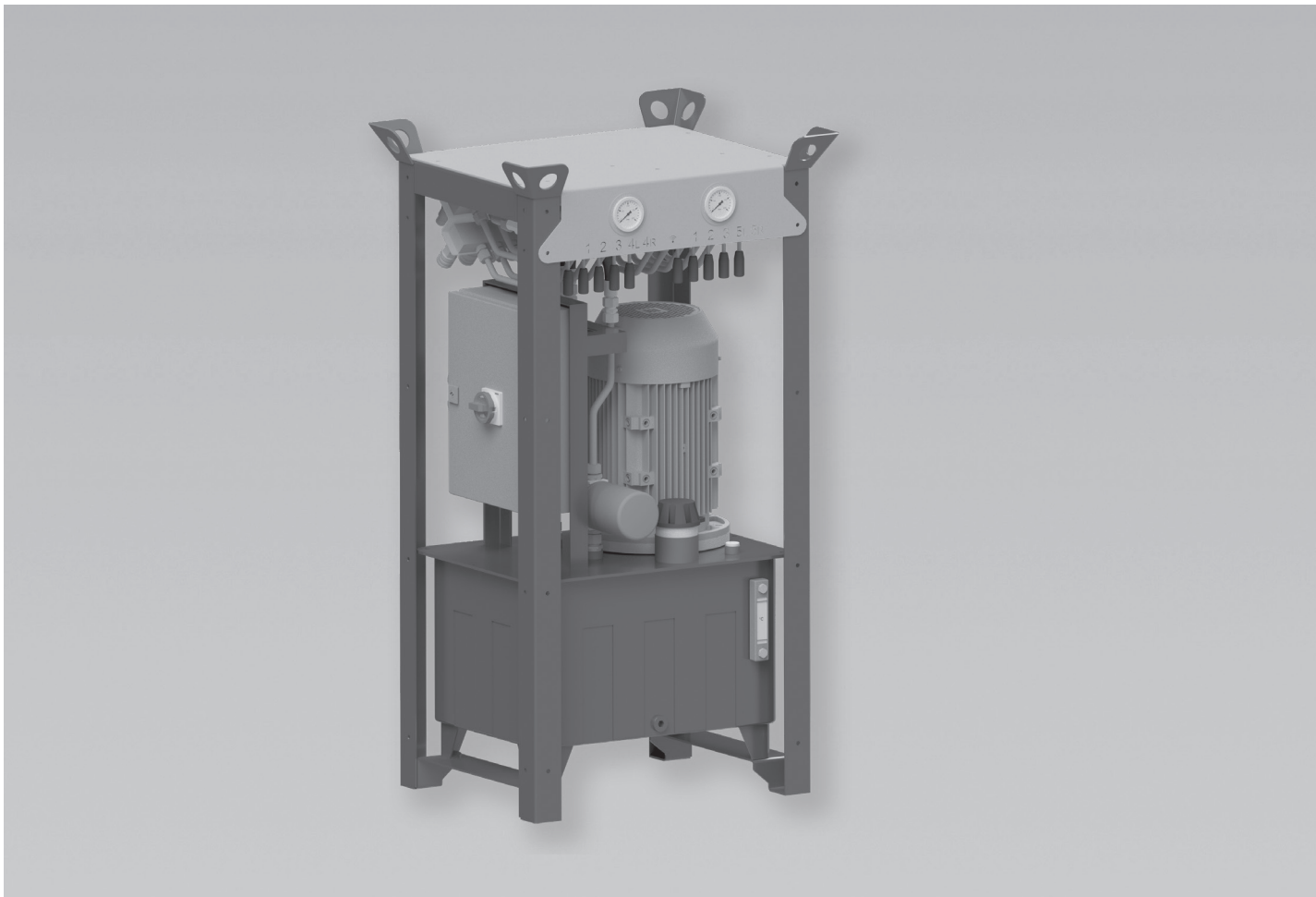

Overview

Main components	4
Key	5

Introduction

Target groups	6
Product description	7
Cleaning and maintenance instructions	8
Disposal	8
Additional technical documentation	9
Instructions for Use	9

Safety instructions

Cross-system	10
System-specific	12
Storage and transportation	15

Component overview and tool list

Component overview	16
--------------------	----

Hydraulics

A1 Storage and transportation	18
A2 Hydraulic unit	19
Overview	19
A3 Hydraulic system	20
Hydraulic connection diagram	20
Components used	21
A4 Commissioning	22
Before initial commissioning	22
Electrical connection	22
Initial commissioning	22
Further commissioning	22
During operation	22
Re-commissioning after a long downtime	22
A5 Maintenance	24
Maintenance plan	24
Reduced interval times	24
Hydraulic oil	25
Replacing oil filter	26
Venting the system	27
Bleeding the cylinder	28
A6 Remedial measures for malfunctions	30

Preparation

B1 Overview of the operating sequence	32
General	32
Standard cycle sequence	32
B2 Anchoring/height adjustment	33
General	33
Lowering the anchoring	34
Raising the anchoring	35
B3 Bottom slab formwork	36
General information	36
Lowering the bottom slab formwork	36
Raising the bottom slab formwork	38
B4 Front carriage	40
General	40
Activating front carriage	41
Deactivating front carriage	42

B5 Rear carriage	44
General	44
Activating rear carriage	45
Deactivating the rear carriage	49

Operation

C1 Drive mode	52
Moving the balanced cantilever equipment forward	53
C2 Pushing the rail forward	56
General	56
Preparations	56
Pushing the rail forward	58
Subsequent work	60

Appendix

Declaration of incorporation	62
------------------------------	----

Product Catalogue

Hydraulics VBC	64
----------------	----



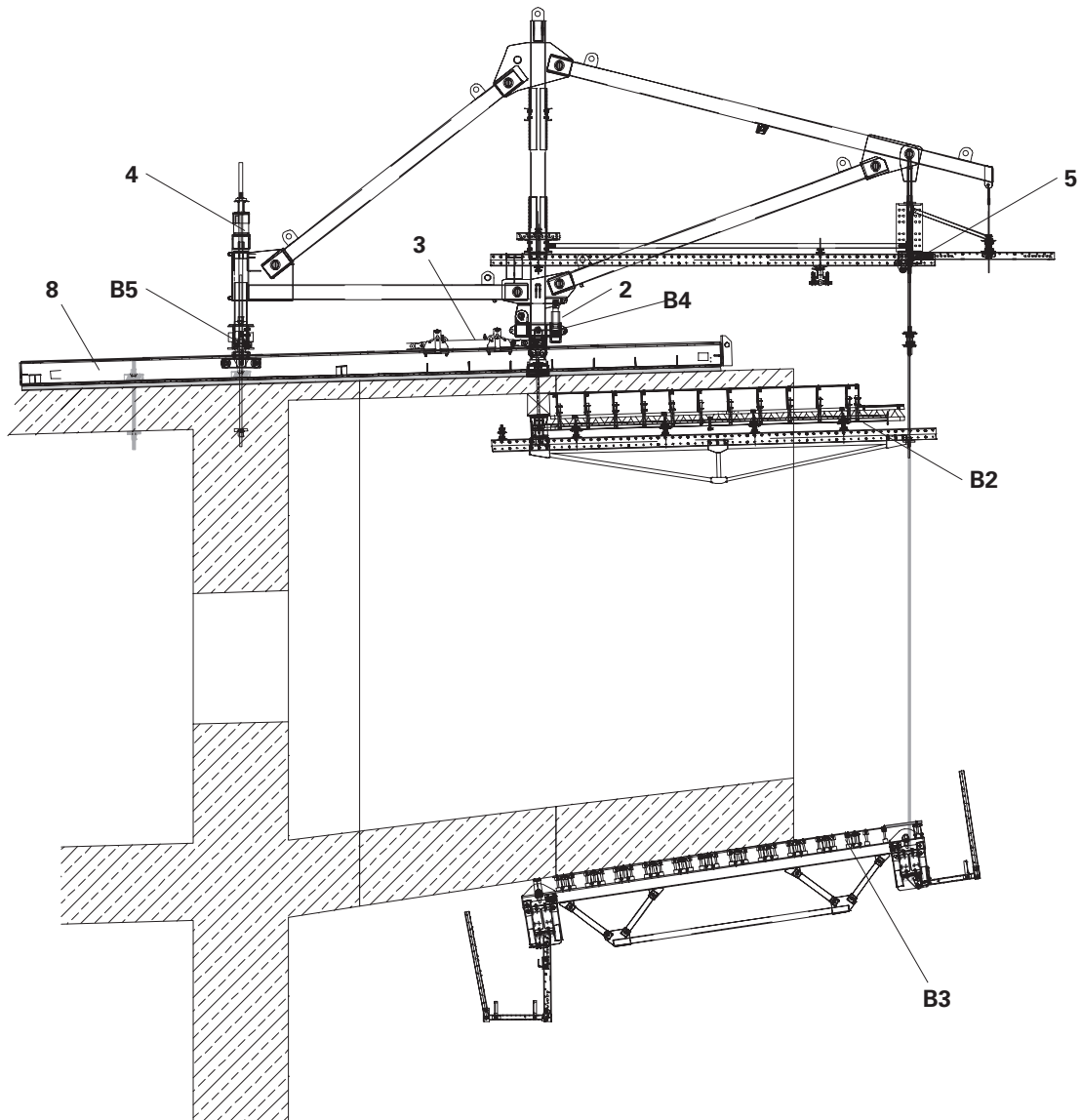









Main components





- B2** Top slab formwork
- B3** Bottom slab formwork
- B4** Front carriage
- B5** Rear carriage
- 2** Front Main Cylinder VBC 280
- 3** Driving Cylinder VBC 280
- 4** Rear Main Cylinder VBC 280
- 5** Lifting and Lowering Cylinder VBC 280
- 6** Pre-Tensioning Jack-2 VBC (not shown)
- 7** Hand Pump-2 VBC (not shown)
- 8** Rail VBC

Key

Pictogram | Definition

	Danger/Warning/Caution
	Note
	To be complied with
	Load-bearing point
	Visual inspection
	Tip
	Incorrect use
	Safety helmet
	Safety shoes
	Safety gloves
	Safety goggles
	Personal protective equipment to prevent falling from a height (PPE)
	Observe additional documentation

Arrows

-  Arrow representing an action
-  Arrow representing a reaction of an action*
-  Arrow representing forces

* If not identical to the action arrow.

Safety instruction categories

The safety instructions alert site personnel to the risks involved and provide information on how to avoid these risks. Safety instructions can be found at the beginning of the section or before instructions for action and are highlighted as follows:

Danger

This sign indicates an extremely hazardous situation that could result in death or serious, irreversible injury if the safety instructions are not followed.

Warning

This sign indicates a hazardous situation that could result in death or serious, irreversible injury if the safety instructions are not followed.

Caution

This sign indicates a hazardous situation that could result in minor or moderate injury if the safety instructions are not followed.

Note

This sign indicates situations in which failure to observe the information can result in material damage.

Format of the safety instructions

Signal word

Type and source of hazard!
Consequences of non-compliance.
⇒ Preventative measures.

Dimensions

Dimensions are usually given in cm. Other measurement units, e.g. m, are shown in the illustrations.

Conventions

- Instructions are numbered with: 1., 2., 3.
- The result of an instruction is shown by: →
- Position numbers are clearly provided for the individual components and are given in the drawing, for example **1**, in the text in brackets, for example **(1)**.
- Multiple position numbers, i.e. alternative components, are represented with a slash: e.g. **1/2**.

Notes on illustrations

The illustration on the front cover of these instructions is understood to be a system representation only. The assembly steps presented in these Instructions for Assembly and Use are shown in the form of examples with only one component size. They are valid for all component sizes contained in the standard configuration.

To facilitate understanding, illustrations are sometimes incomplete. Safety equipment not shown must still be present.

Terminology

Components are not always named in full so that they are easier to read. All components deemed valid according to the program overview may be used. Exceptions are specified.

Target groups

Contractors

These Instructions for Assembly and Use are designed for contractors who either

- assemble, modify and dismantle PERI systems, or
- use them, e.g. for concreting, or
- allow them to be used for other operations, e.g. carpentry or electrical work.

Safety and Health Protection Coordinator*

- is appointed by the client,
- must identify potential hazards during the planning phase,
- determines measures that provide protection against risks,
- creates a safety and health protection plan,
- coordinates the protective measures for the contractor and site personnel so that they do not endanger each other,
- monitors compliance with the protective measures.

Competent person

- is appointed by the contractor,
- must be on site for all system operations,
- prepares and updates the plan for assembly, modification and dismantling,
- prepares and updates the plan for use of the system by the user,
- supervises the assembly, modification and dismantling work (supervisor).

Competent persons qualified to carry out inspections

Due to the specialist knowledge gained from professional training, professional experience and recent professional activity, the competent person qualified to carry out inspections has a reliable understanding of safety-related issues and can carry out inspections correctly. Depending on the complexity of the inspection to be undertaken, e.g. scope of testing, type of testing or the use of certain measuring devices, a range of specialist knowledge is necessary.

Qualified personnel

PERI systems may only be assembled, modified or dismantled by personnel who are suitably qualified to do so. Qualified personnel must have completed a course of training** in the work to be performed, covering the following points at least:

- Explanation of the plan for the assembly, modification or dismantling of the system in an understandable form and language.
- Description of the measures for safely assembling, modifying or dismantling the system.
- Naming of the preventive measures to be taken to avoid the risk of persons and objects falling.

- Designation of the safety precautions in the event of changing weather conditions that could adversely affect the safety of the system, as well as the personnel concerned.
- Details regarding permissible loads.
- Description of all other risks and dangers associated with assembly, modification or dismantling operations.



- **Ensure that relevant national guidelines and regulations in the respective current version are complied with!**
- **If no country-specific regulations are available, it is recommended to proceed according to German guidelines and regulations.**

* Valid in Germany: Regulations for Occupational Health and Safety on Construction Sites 30 (RAB 30).

** Instructions are given by the contractor themselves or a competent person selected by them.

Product description

Intended use

PERI products have been designed for exclusive use in the industrial and commercial sectors only by suitably trained personnel.

The hydraulic system of the VBC Balanced Cantilever Equipment is used to transport the balanced cantilever equipment from one concreting section to the next.

Functionality

The balanced cantilever equipment is lifted onto the chassis by means of hydraulic cylinders and is moved with hydraulic cylinders.

The constructional systems presented in these Assembly Instructions are shown in the form of examples with only one component size. They are valid for all component sizes contained in the standard configuration.

Any deviations are described in the project-specific planning.

These Assembly Instructions describe:

- Lowering and raising the top and bottom slab formwork
- Activation of the front and rear carriages
- Hydraulic moving procedure of the balanced cantilever equipment
- Deactivation of the carriages
- Advancing the rail to the next moving section.

Not part of these Assembly Instructions:

- Transport and pre-assembly on the construction site.
- Installation on site (bridge pier).
- Assembly of the rafters and formwork.
- Return journey to the bridge pier or bridge bearing.
- Dismantling of the formwork and rafters.
- Dismantling and removal.

This work is to be determined on a project-specific basis and monitored by a coordinator on the construction site.

Cleaning and maintenance instructions

In order to maintain the value and operational readiness of the formwork materials over the long term, clean the panels after each use.

Some repair work may also be inevitable due to the tough working conditions.



The contractor must ensure that the personal protective equipment required for cleaning, maintenance and repair work such as

- Safety helmet,
- Safety shoes,
- Safety gloves,
- Safety goggles,

is available and used as intended.

The following instructions should help to keep cleaning and maintenance costs as low as possible.

Cleaning tools must be adapted to the respective surfaces of the components so that they are not damaged.

Spray the formwork on both sides with concrete release agent before each use; this makes the formwork easier and faster to clean. Spray the concrete release agent very thinly and evenly!

Do not spray work platforms and access routes with concrete release agent.

Slip hazard.

Spray the rear side of the formwork with water immediately after concreting; this avoids any time-consuming and costly cleaning operations.

When used continuously, spray the formlining elements with concrete release agent immediately after deshuttering; then clean by means of a scraper, brush or rubber lip scraper. Important: do not clean formlining made of plywood with high-pressure equipment. This could result in the formlining being damaged.

Fix recesses and built-in parts with double-headed nails; as a result, the nails can easily be removed later, and damage to the formlining is largely avoided.

Close all unused tie holes with plugs; this eliminates any subsequent cleaning or repair work.

Tie holes accidentally blocked with concrete are cleared by means of a steel pin from the formlining side.

When placing bundles of reinforcement bars or other heavy objects on horizontally stored formwork elements, suitable support, e.g. squared timbers, is to be used: this prevents impressions and damage to the formlining to a large extent.

Internal concrete vibrators should be fitted with rubber caps if possible; as a result, any damage to the formlining is reduced if the internal vibrator is accidentally inserted between the reinforcement and formlining.

Never clean powder-coated components, e.g. elements and accessories, with steel brushes or hard metal scrapers; this preserves the powder coating. Use spacers for reinforcements with large or flat support brackets; this largely prevents indentations in the formlining when under load.

Mechanical components, e.g. spindles or gear mechanisms, must be cleaned of dirt or concrete residue before and after use, and then greased with a suitable lubricant.

Provide suitable support for the components during cleaning so that no unintentional change in their position is possible.

Do not clean components suspended on crane lifting gear.

Disposal

Carry out disposal in accordance with the relevant national regulations.

Additional technical documentation

- Project-specific documentation
- Documentation provided by the hydraulic manufacturer for
 - Hydraulic Unit VBC 280
 - Front main cylinder
 - Drive cylinder
 - Rear main cylinder
 - Lifting and lowering cylinder
 - Pre-tensioning jack
 - Hydraulic hand pump
- Safety Data Sheet of the hydraulic oil manufacturer

Instructions for Use

Use in a way that is not intended according to the Instructions for Use or deviations from the standard configuration or intended use constitute incorrect use with a safety risk, e.g. risk of falling.

Only PERI original components may be used. The use of other products and spare parts is not allowed and represents a misapplication with associated safety risks.

Changes to PERI components are not permitted.

Only ever use approved and calculated components.

Operation with damaged or incomplete load-carrying equipment is not permissible.

The system described in these Instructions for Assembly and Use may contain patent-protected components.



- The description of the assembly and operation of the assemblies and components in these Instructions for Assembly and Use is intended as an example.
- For use on the construction site, a project-specific assembly plan is required.
- The project-related assembly plan from PERI is binding for assembly operations.

Cross-system



Safety instructions apply to all service life phases of the system.

General information

The contractor must ensure that the Instructions for Assembly and Use supplied by PERI are available at all times and understood by the site personnel.

These Instructions for Assembly and Use can be used as the basis for creating a risk assessment. The risk assessment is compiled by the contractor. The Instructions for Assembly and Use are not a substitute for a risk assessment!

Observe and comply with the safety instructions and permissible loads.

For the application and inspection of PERI products, the current safety regulations and guidelines valid in the respective countries must be observed.

Materials and working areas are to be inspected before each use and assembly for:

- damage,
- stability and
- functional correctness.

Damaged components must be exchanged immediately on site and may no longer be used.

Safety components are to be removed only when they are no longer required.

When on slab formwork, scaffolds and working platforms:

- do not jump,
- do not run,
- do not drop anything from or onto it.

Components provided by the contractor must comply with the characteristics stipulated in these Instructions for Assembly and Use and all applicable laws and standards. Unless otherwise indicated, the following applies in particular:

- Timber components:
Strength class C24 for solid wood according to DIN EN 338:2016-07.
- Scaffolding tubes:
Galvanised steel tubes with minimum dimension \varnothing 48.3 mm x 3.2 mm according to DIN EN 12811-1:2004-03 4.2.1.2.
- Scaffolding tube couplings:
according to DIN EN 74-1:2022-09 and DIN EN 74-2:2022-09.

Deviations from the standard configuration are only permitted after a further risk assessment has been carried out by the contractor.

Appropriate measures for working and operational safety, as well as stability, are defined on the basis of this risk assessment.

Corresponding proof of stability can be provided by PERI on request if the risk assessment and resulting measures to be implemented are made available.

Nails and wood screws must not protrude. Only allow other connecting components to protrude to the extent that is necessary.

If necessary, mark protruding components or fit them with protective material.

Secure all bolts with cotter pins and all screws with nuts

Before and after extraordinary events that may have damaging effects on the safety of the system, the contractor must immediately

- produce another risk assessment, the results of which must be used to implement suitable measures to ensure the stability of the system,
- arrange for an extraordinary inspection to be carried out by a competent person qualified to do so. The aim of this inspection is to detect and repair damage in good time in order to ensure safe use of the system.

Exceptional events could be:

- accidents, fire, explosions, collisions,
- long periods of non-use,
- natural events, e.g. heavy rainfall, heavy snowfall, significant icing, storms or earthquakes.

Suitable measures could be:

- removing nets/tarpaulin,
- clearing snow and ice,
- reducing live loads,
- securing loose materials.

Assembly, modification and dismantling work

PERI systems may only be assembled, modified or dismantled under the supervision of a person qualified to do so and by technically suitable employees. The qualified personnel must have received appropriate training for the work to be carried out with regard to specific risks and dangers.

On the basis of the risk assessment and Instructions for Assembly and Use, the contractor must create installation instructions in order to guarantee safe assembly, modification and dismantling of the climbing unit.



The contractor must ensure that the personal protective equipment required for the assembly, modification or dismantling of the scaffolding system, e.g.

- Safety helmet,
- Safety shoes,
- Safety gloves,
- Safety goggles

is available and used as intended.

For work at a higher level, use an approved ladder or platform system, or an assembly scaffold.



If personal protective equipment against falling from a height (PPE) is required or specified in local regulations, the contractor must determine appropriate attachment points on the basis of the risk assessment.

The PPE to be used to prevent falling is determined by the contractor.

The contractor must

- provide safe working areas for site personnel, which are to be reached through the provision of safe access ways. cordon off and clearly mark danger zones.
- guarantee stability during all stages of construction, in particular during assembly, modification and dismantling operations.
- ensure and demonstrate that all loads that occur are safely transferred.

Use

Every contractor who uses or allows the PERI systems to be used is responsible for ensuring that the equipment is in good condition.

If the system is used successively or at the same time by several contractors, the health and safety coordinator must point out any possible mutual hazards and all work must be then coordinated.

When systems are used in publicly accessible areas

- measures to prevent unauthorised use, e.g. enclosure of access areas, must be taken.
- Measures are taken against injuries caused by bumping against protruding components, e.g. assembly of protective components.

Always keep the contact surfaces of the system free of dirt, objects, snow and ice.

Close off the system in extreme weather conditions.

System-specific



Safety instructions apply to all service life phases of the system.

Make sure that the guardrails and/or edge covers at building openings and projections are fully installed before accessing the system.

Before entering the system, check for completeness of the platform deck and for danger spots and use PPE if necessary.

Deshutter the concreting sections only when the concrete has sufficiently hardened and the person in charge has given the go-ahead for deshuttering to take place.

Anchoring is to take place only if the anchorage has sufficient concrete strength.

The anchoring of the balanced cantilever equipment can only be released or fixed on the instructions of the person in charge.

The moving procedure must be monitored by the person in charge at all times.

Inspection of the anchoring and associated components must be carried out by the party responsible.

As a result of the relocation procedure, falling edges are formed between the platforms. Such affected areas are to be cordoned off.

Building materials or tools must not be transported as part of the relocation operation. Exceptions to this can be determined through the operational working and assembly instructions.

The transport of persons during the relocation process is strictly prohibited. This does not apply to the operating personnel required for relocation operations.

Working areas at great heights are to be secured by means of appropriate measures to prevent objects from falling down.

The enclosure of the platform or mounting of additional surfaces exposed to the wind changes the degree of stability and must be rechecked. If necessary, additional measures must be implemented.

Use a guide rope to ensure that assembly units suspended from the crane are fully under control when being moved.

Welding or abrasive cutting work is prohibited on the platform due to the associated fire hazard.

Reliable lightning conduction must be ensured by the contractor.

Assembly work

The contractor must ensure that the user has an appropriate and sufficient number of tools, lifting equipment and slings, suitable and sufficient space for assembly and storage as well as adequate crane capacity at his disposal.

During the transportation procedure, only use the specified attachment points for components.

Avoid standing under suspended loads. If work under suspended loads cannot be avoided, come up with suitable safety measures and apply them. Avoid standing between a fixed object and an object that is drawing near.

Secure interim assembly states by means of temporary supports in order to prevent any items from toppling over.

The contractor must make a level assembly area with sufficient load-bearing capacity available.

Unexpected hazards can always arise when assembly work is carried out. Assess the degree of risk in each individual case and, if necessary, take measures to prevent or minimise the risk.

If guardrails cannot be used or have to be removed due to operational reasons, safety equipment must be installed in its place in order to prevent falls from any height.

If the use of anti-fall equipment is deemed to be inappropriate, personal protection equipment (PPE) can be used if suitable fixing points are available.

Site personnel are forbidden to remain in areas below where assembly work is being carried out, unless the danger zone has been provided with sufficient protection against falling, overturned, sliding or rolling objects and masses. Cordon off and clearly mark any danger zones and check that these are in place and complete every time work is commenced.

Do not walk on components and assembly units.

Find a secure standing position next to the components or assembly units. Use assembly scaffolds.

Always keep components and assembly units free of dirt, ice and snow.

Access

Safe access to all working areas must be guaranteed at all times.

Hatches and openings to accessible working areas must be kept closed during working operations.

Use walkways, stairs, stair towers or site lifts as access routes. Ladders are suitable for use as access routes in exceptional cases only.

Ladders must not be connected to each other for more than two levels and should be offset against one another.

Ladders must be secured on the outer side by means of appropriate anti-fall equipment such as ladder cages or safety nets.

Building edges at passages and openings in accessible areas must be secured.

In case of danger, it must be ensured that working areas can be vacated via emergency escape routes or rescue equipment.

It must also be ensured that at least one emergency escape route or piece of rescue equipment can still be used if the power supply fails.

Determine and apply all appropriate measures.

Throughout the entire relocation procedure, ensure that site personnel can still use the emergency escape route.

In case the access hatches are blocked when retracting the formwork, ensure that site personnel can still use the emergency escape route.

Protection against falling components

Work activities may not be carried out simultaneously on areas positioned on top of each other if the lower working areas are not protected against falling objects.

Avoid installing working areas and access routes in danger zones. If this is not possible due to work procedures, suitable protective measures must be available to provide protection against falling objects. This also applies to work that only takes a short period of time.

Safety nets (mesh size ≤ 2 cm) and platform planking are considered to be suitable means and are to be installed very close to the structure (distance ≤ 5 cm).

Secure tools and material to prevent them from falling down. Remove concrete residue and other dirt as soon as possible, at the latest before the next climbing cycle. The platforms are to be kept clean at all times.

Operational working areas at great heights are to be secured by means of appropriate structural measures to prevent objects from falling down.

Components at risk of structural collapse

Secure components that are likely to become unstable with suitable means, e.g. using push-pull props, or leave them attached to the crane until the tipping hazard has been eliminated.

Loitering in the tipping range is prohibited. Draw attention to and clearly mark any danger zones.

If necessary, cordon off the danger zones with suitable means. Check that safety signs and barriers are in place before commencing work.

Drive mode

Take into consideration the permissible wind speed limit for drive mode.

In drive mode, clamping and crushing hazards are created by moving components.

The individuals carrying out the climbing procedure must be fully informed about all possible hazards.

All persons who are not required to carry out the moving procedure must leave the danger zones.



Note

Moving the balanced cantilever equipment is only permitted if the brakes are actuated.

The equipment must always be fitted with brakes.

Maintenance and repairs

The components of the system are to be inspected before every use to ensure that they are in flawless condition. Only flawless materials may be used. Have the system checked monthly for signs of damage by competent persons who are authorised to give instructions.

Remove any loose concrete residue.

Immediately remove any dirt that impairs functionality. Remove and replace damaged components.

In case of overload or damage, stop work on and under the platforms, determine the cause, set down and replace damaged components.

If the maximum permissible wind speed has been exceeded, temperatures are outside the area of application or after any extraordinary event has taken place such as a fire or earthquake, the functionality and load-bearing capacity of all safety components as well as the supporting structure must be checked.

Supporting structure:

- A visual inspection is to be carried out by authorised personnel before initial use.
- Only PERI original components are to be used for repairs or replacement.
- In the case of overloading or recurrent damage, stop work operations on and under the platforms, determine the cause and rectify.

Other components:

- Repairs are carried out by authorised personnel and the person authorised to give instructions is to be informed.
- In the event of frequently recurring damage, determine the cause and remedy it.
- Route hydraulic lines and power cables in such a way that they cannot be disconnected or sheared off, and that they do not pose a tripping hazard.

Hydraulic components

Visual inspections are to be carried out by authorised personnel at regular intervals.

Qualified personnel are to carry out a functionality check before every working cycle or before assembly takes place.

If any defects are discovered, repairs are only allowed to be carried out by qualified personnel.

Hydraulic hoses have an expiry date. Observe the manufacturer-specific information.

Do not suspend any objects from the hydraulic hoses.

Observe the manufacturer-specific information regarding inspection and maintenance of the hydraulic unit.

For correct use and disposal of the hydraulic oil, observe the manufacturer-specific instructions.

Thicken spilled hydraulic oil immediately with oil binder and mop it up.



- Wear safety goggles and suitable protective gloves when working on the hydraulic system.
- Avoid contact with hydraulic fluid.



PERI recommends the use of an oil pan to collect hydraulic oil from the hydraulic unit.



For safe and professional handling of hydraulic components, observe the documentation of the respective manufacturer.

Note

Always switch off the power to the hydraulic unit and prevent it from being switched on again as soon as the moving procedure involving the climbing system has been completed.

This safety measure also applies to the following:

- Assembly.
- Maintenance.
- Repairs.
- Inspections.
- Dismantling.

Approval for use is the responsibility of the operating personnel.

Electrical components

Danger

High electric voltage at the hydraulic unit!

Death or serious injury can result from an electric shock.

- ⇒ Connection only by qualified personnel.
- ⇒ Only qualified personnel may carry out work and repairs on the electrical components of the systems.
- ⇒ Only approved, undamaged and tested connecting cables should be used.

Only operate the hydraulic unit with the type of current and voltage specified on the type plate.

Do not suspend any objects from the electrical lines.

Storage and transportation

Store and transport components in such a way that no unintentional change in their position is possible. Detach lifting accessories and lifting gear from the lowered components only if they are in a stable position and no unintentional change is possible.

Do not drop the components.

Use PERI lifting accessories and lifting gear and only those load-bearing points provided on the component.

During the relocation procedure

- ensure that components are picked up and set down in such a way that unintentional falling over, falling apart, sliding, falling down or rolling is avoided.
- no one is allowed to remain under the suspended load.

Pre-assembled assemblies should always be guided with ropes when moving them by crane.

The access areas on the construction site must be free of obstacles and tripping hazards, as well as being slip-resistant.

For transportation, the substrate must have sufficient load-bearing capacity.

Use original PERI storage and transport systems, e.g. crate pallets, pallets or stacking devices.

Component overview

Pos. no.	Component name	Article no.
1	Hydraulic Unit VBC 280	132242
2	Front Main Cylinder VBC 280	132243
3	Drive Cylinder VBC 280	132244
4	Rear Main Cylinder VBC 280	132245
5	Lifting and Lowering Cylinder VBC 280	132246
6	Pre-Tensioning Jack-2 VBC	132249
7	Hand Pump-2 VBC	132250
8	Rail VBC	128997
9	Chuck VBC	129660
10	Cylinder Table VBC	
21	Drive Catch Head-2 VBC	134596
23	Main Frame Chord VBC	129108
24	Main Frame Post VBC	129100
25	Rear Carriage Tube VBC	129068
26	Rear Carriage Rocker VBC	129078
27	Rear Cylinder Head VBC	129091
28	Hold-down Bracket VBC	129641
29	Sliding Plate VBC	129642
30	Post Base VBC	129083
31	Front Carriage VBC	129077
32	Head Pawl Pin VBC	129003
33	Lifting Shim VBC 20	129612
34	Lifting Jack Bracket VBC	129609
35	Lifting Counterplate VBC	129614
36	Roller Block VBC	129009
51	Auxiliary tie rod	
52	Anchor tie rod	
53	Main tie rod	
61	Tie nut straight	130598
62	Domed nut	
63	Main tie nut	
64	Hexagonal coupler	

Moving on the construction site

- Keep bushing and nipples of all quick-couplers clean and fitted with protective caps or coupled together during transport.
- Transport the hydraulic cylinder only with the piston rod in a retracted position.
- Transport the hydraulic hoses rolled up and do not drag them along the ground.

Temporary storage on the construction site

- Clean the bushings and nipples of all quick-couplers and fit with protective caps, or connect together.
- Store the hydraulic cylinder only with the piston rod in a retracted position.
- Store the hydraulic hoses rolled up.
- When storing, place the hydraulic cylinder in its designated transport box.
- Do not store hydraulic units horizontally, as oil can escape through the vent valve.

Transport from and to the construction site

- Clean dirt off the hydraulic cylinders and hydraulic units, and dry them.
- Fit bushing and nipples of all quick-couplers with protection caps or couple them together.
- Transport the hydraulic hoses rolled up.
- Fill the hydraulic cylinder and hydraulic hoses with oil.
- Transport the hydraulic cylinder only with the piston rod in a retracted position.
- For transport, place the hydraulic cylinders and hydraulic units in the transport boxes provided and fix them in place.
- Do not transport hydraulic units lying down, as oil can escape through the vent valve.
- When moving transport crates with the crane, use only suitable lifting slings that are wrapped around the underside.

Longer storage periods

- Do not drain the hydraulic oil during downtime.
- Protect connections against corrosion using a suitable preserving agent. Close all openings so they are airtight.
- If stored in regions characterised by high humidity, also fill the hydraulic oil tank to the brim with hydraulic oil and ensure that the unit is firmly closed.

Overview

Components

- 1 Hydraulic Unit VBC 280
- 1.1 Pressure gauge
- 1.2 Hand valve
- 1.3 Filling opening for hydraulic oil
- 1.4 Level and temperature display
- 1.5 Oil tank
- 1.6 Oil drain plug
- 1.7 Oil filter
- 1.8 Switches with emergency stop function
- 1.9 Rotary field display
- 1.10 Mounting frame with attachment points for transportation by crane
- 1.11 Inflow for piston head side
- 1.12 Return flow for piston rod side
- 1.13 Bushing for power supply

2-circuit hydraulic system

The Hydraulic Unit VBC 280, e.g. Weber, type LO 17028/1, is equipped with a separate pump for each of the two "right" and "left" valve groups. This ensures load-independent synchronisation of the cylinder.

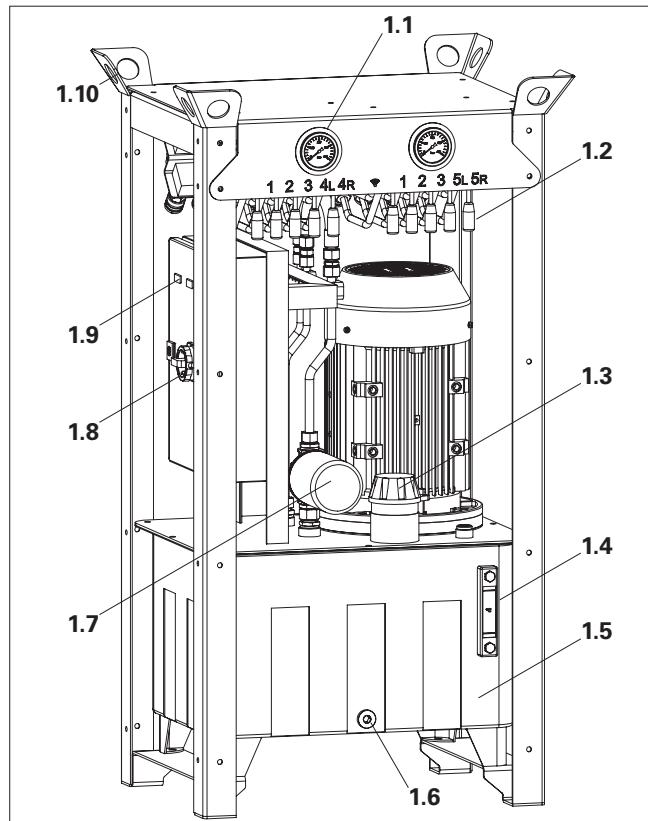

Fig. A.01

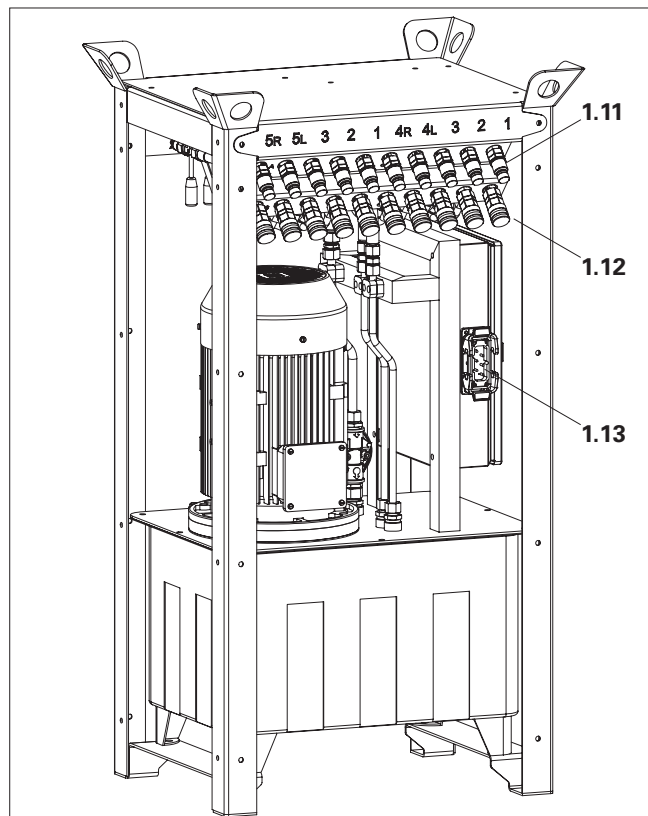

Fig. A.02

Hydraulic connection diagram

The hydraulic system is divided into 5 lines as well as "right" and "left" valve groups.

PERI recommends assigning the control valves in the viewing direction as shown in the illustration.

Exception

The control valves for cylinders 4R and 4L are assigned to the left valve group while cylinders 5R and 5L are assigned to the right valve group.

This allows both lines to be controlled simultaneously and uniformly. If connected differently, the heavier part of the platform would run ahead or trail.

1R/1L Front main cylinder

2R/2L Drive cylinder

3R/3L Rear main cylinder

4R/4L Rear lifting and lowering cylinder

5R/5L Front lifting and lowering cylinder

Connecting the hydraulic lines

Only use hydraulic hoses DN08. Other nominal sizes do **not** have the required pressure resistance.

Hose lengths must be determined on a project-specific basis.

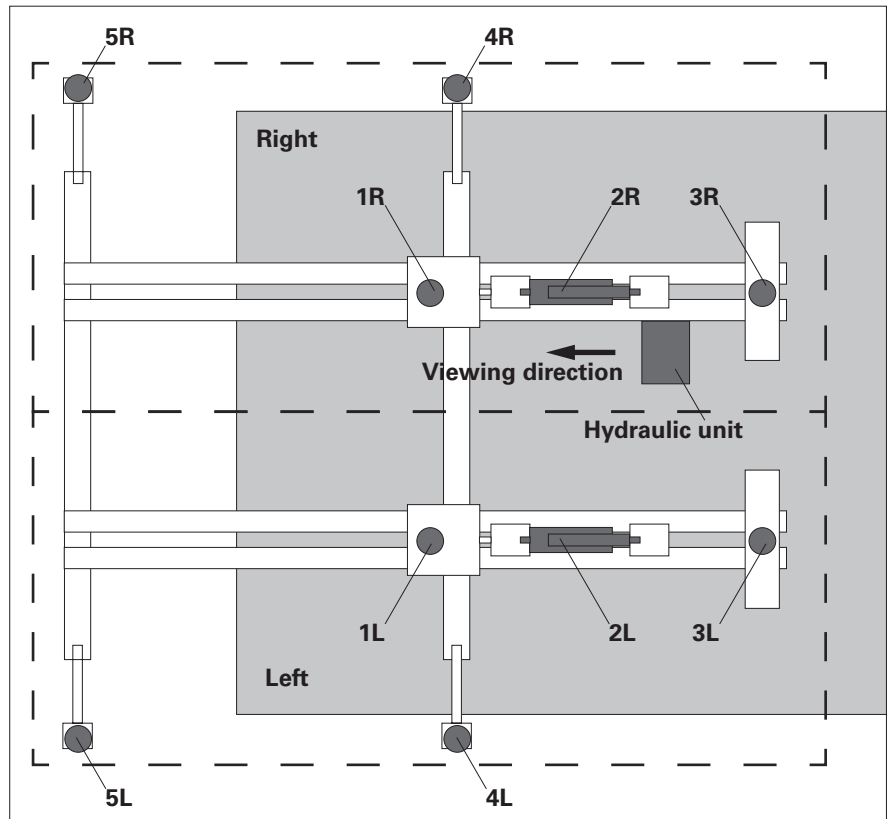

Fig. A.03



The arrangement of the plugs and sockets of the quick-couplers is clearly shown and cannot be mixed up.

Assembly

1. Clean nipples and bushings.
2. Push the nipple as far as possible into the bushing until the retaining ring engages.
3. Turn retaining ring with a quarter-turn (right or left) = secured. Accidental disconnection is thus prevented.

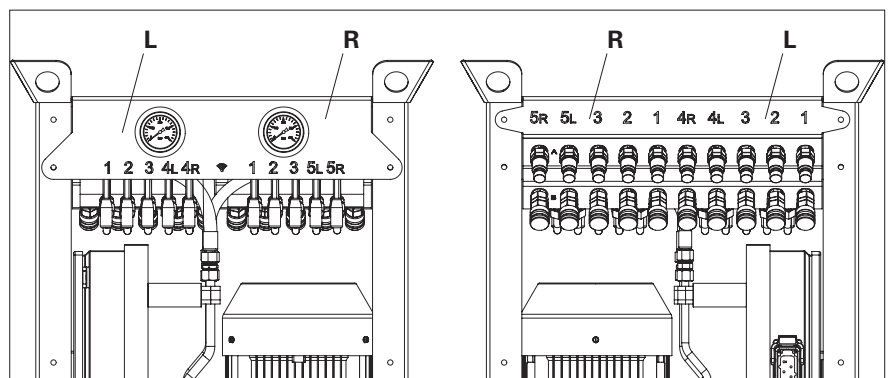

Fig. A.04

Front/operating side

Rear/connection side

Components used

As a rule, the following components are used. Take the project-specific documentation into account!

Reference	Designation Manufacturer (e.g.) Type (e.g.)	Nominal load		Area		Article
		Pressing at 280 bar	Pulling at 280 bar	Piston side	Piston rod side	
1R/1L	Front main cylinder Weber LD28-180/110-150-FWF-000	713 kN	446 kN	254.5 cm ²	159.4 cm ²	132243
2R/2L	Drive cylinder Weber LD28-120/70-650-FWF-000	316 kN	209 kN	113.1 cm ²	74.6 cm ²	132244
3R/3L	Rear main cylinder Euro Press Pack COF083N200X1	574 kN	–	205.0 cm ²	–	132245
4R/4L 5R/5L	Lifting and lowering cylinder Euro Press Pack COF034N250X1	235 kN	–	84.2 cm ²	–	132246
6	Pre-tensioning jack Euro Press Pack CMF60N75					132249
7	Hydraulic hand pump Weber PN141					132250

Nominal load details without pressure and friction loss

Before initial commissioning

- Check the completeness of the technical documentation, e.g. hydraulic plan, equipment list, electrical wiring diagram, instructions for switch and motor.
- Site personnel must familiarise themselves with the system using the available documentation.
- Compare required type of current and voltage with that specified on the type plate.
- Check the rotary field.
- Check that the oil tank is clean.
- Check hydraulic oil for cleanliness.
- Fill tank with hydraulic oil. For this, use a filter pump or clean universal funnel.
- Check temperature of the electric motor.
- Check temperature of the hydraulic oil and, if necessary, bring it up to operating temperature by means of free circulation.
- Clean the bushings and nipples of all quick-couplers, and check for damage.
- Check all fittings and re-tighten if necessary.
- Carefully vent the system during initial commissioning or after temporary storage.

Electrical connection

Connection only by qualified personnel!

Accessories:

- Power cable VBC 280 CEE -16A-2M
Article no. 132247
- Power socket VBC 280 16A
Article no. 132248

Initial commissioning

Measures taken during commissioning

- Check the rotary field.
- Check the level of the hydraulic oil and top up, if necessary.
- Check temperature of the hydraulic oil and, if necessary, bring it up to operating temperature.
- Listen out for any pump noises after starting up.
- Carefully vent the system during initial commissioning or after temporary storage.
- Check the functionality of the hand valves and hydraulic cylinders.
- Check components and connections for external leaks.
 - Re-tighten leaking screw connections only after pressure release has taken place! Never re-tighten under high pressure!
- Check filter and, if necessary, clean or replace.

Further commissioning

- Check the level of the hydraulic oil and top up, if necessary.
- Check temperature of the hydraulic oil and, if necessary, bring it up to operating temperature.
- Listen out for any unusual pump noises.
- Check components and connections for external leaks.
 - Re-tighten leaking screw connections only after pressure release has taken place! Never re-tighten under high pressure!

During operation

- Monitor the temperature of the hydraulic oil.
- Monitor the temperature of the electric motor.
- Listen out for any unusual pump noises.

Re-commissioning after a long downtime

- Thoroughly clean and rinse preserved equipment before commissioning. Any remaining preservation agents can block the valves.
- Drain condensation water from the hydraulic tank.
- After a long downtime period, check hydraulic oil for usability and change if necessary.



All recommended measures for initial commissioning also apply to re-commissioning.



At low temperatures of < 10 °C, warm up hydraulic oil by flushing the system in order to reach the required start viscosity.

Maintenance plan	
Task	Recommended maintenance intervals
Clean concrete splatter off cylinder rods.	Immediately
Clean machine housing and cylinder. Lubricate moving parts on the cylinder.	Daily
Clean or replace oil filter. Change hydraulic oil.	Before use on next construction site, at least 1x per year
Replace hoses.	If damaged Before use on next construction site, at least 1x per year
Replace seals.	In case of oil leakage
Check the fluid level in the oil tank. Check oil temperature and oil level. Check for signs of leakage. Check working and control pressures. Check whether any unusual noises or vibrations are present.	Daily to weekly
Check: Equipment fixings Pipe and hose lines (connections, chafe marks, kinks) Protective covers, display devices Ventilation filter in the filling piece	Weekly to monthly
Check: Machine housing (contamination, damage) Performance check	Monthly to quarterly
Check the entire hydraulic unit (deposits, rust formation).	Yearly

Reduced interval times

PERI recommends shortened maintenance intervals:

- For equipment showing signs of heavy wear.
- With high thermal and mechanical loads.
- When subject to heavy soiling.

Hydraulic oil



Warning

Hydraulic oil can cause health problems!

- ⇒ Instructions for the safe handling of hydraulic oil are included in the safety data sheet of the oil selected for use.
- ⇒ Avoid contact with skin and eyes as well as contact with the structure. For information on cleaning and correct disposal, see the safety data sheet of the hydraulic oil selected for use.



Caution

Hydraulic unit and hydraulic oil are hot after operation!

- This could result in burns and scalding!
- ⇒ Allow the hydraulic unit to cool down before maintenance! The cooling down time depends on the ambient conditions and has to be adapted accordingly.

Check oil level

Liquid volume too low

- the operating temperature increases,
- air inclusions occur,
- the hydraulic cylinder may extend jerkily.

Therefore:

- Keep the oil level display device clean.
- Monitor the oil level continuously.
- Immediately top up any missing hydraulic oil.
- Observe pendulum volume, do not overfill. Only top up the oil when all cylinders have been retracted.
- Identify causes of excessive oil consumption.



The oil level can vary depending on the type, quantity and size of the consumer.

Checking oil temperature



Note

The operating temperature of the hydraulic oil increases with an increase in the outside temperature. Excessive oil temperature can cause damage to the hydraulic system.

- ⇒ If the oil temperature exceeds 70 °C, switch off the hydraulic unit.
- ⇒ Determine the cause of overheating (e.g. no pressureless flow, outside temperature is too high ...).



Recommended operating temperature of the hydraulic oil: see information provided by the oil manufacturer.

Changing hydraulic oil

Drain hydraulic oil and clean oil tank:

1. Completely retract the piston rods.
2. Clean the hydraulic tank, especially in the area of the filling piece.
3. Switch off the unit and drain the hydraulic oil when warm.
4. Remove the oil drain screw.
5. Completely drain the tank.
6. Clean the hydraulic tank if necessary.
7. Clean the return flow filter or replace if necessary.
8. Check the ventilation filter in the filling piece for signs of dirt.
9. For extremely dirty equipment or when changing the hydraulic oil, rinse with separate oil.
10. Drain flushing oil from the hydraulic tank and clean once again if necessary.

Filling with new hydraulic oil:

1. Fill tank with hydraulic oil.
 - Fill tank only up to the top marking. Do not overfill!
 - The hydraulic oil used must be free of water and dirt.
 - Pour in the hydraulic oil using a filter pump or clean filling sieve (separate filling sieve, filling funnel with sieve insert, or using an ultra-fine filter).
 - Do not mix hydraulic oils of different manufacturers and quality.
2. Close the filling opening with an end cap.
3. Check oil level.
4. Check the tightness of the oil tank (e.g. caps, pipe penetrations, flanges).
5. Record the type of oil used and volume in the maintenance chart and note down on the unit.

Recommended hydraulic oil:

HM10 – ISO 11158, art. no. 131270.

HVI22 – ISO 11158, art. no. 131274

HVI46 – ISO 11158, art. no. 057376

Observe temperature range and viscosity in accordance with the manufacturer's documentation.

Filling quantity of oil tank: max. 70 litres

Replacing oil filter

Preparations

1. Completely retract all hydraulic cylinders, lower all loads. Alternatively, short circuit all hydraulic lines. See "Venting the system" on page 27.
2. Switch off the hydraulic unit and disconnect the mains plug.
3. Remove residual pressure by actuating the control valves.
4. **Caution!**
Hot surface, hot oil!
Allow system to cool down.
5. Prepare collection tray and cleaning cloths/cleaning rags to deal with overflowing oil.
6. Secure the system against being switched on.

Assembly

1. Carefully clean the area around the filter.
2. If necessary, unscrew the oil filter from the filter head in the anti-clockwise direction by means of a strap wrench. Collect and correctly dispose of any leaking oil.
3. Remove the protective cover from the new filter element and attach it on the used filter element.
 - Do not reuse the residual oil in the used filter element, and correctly dispose of it together with the element.
4. Uniformly wet the sealing ring of the new filter element with hydraulic oil.
5. Hand-tighten the filter element onto the filter head – no tools required.
6. After the hydraulic system has become operational again, check for leaks as well as the oil level. Top up as required.

Disposal

1. Mop up any excess hydraulic oil with cleaning rags.
2. Correctly dispose of the used filter element and oil-contaminated auxiliary materials.

Venting the system

In order to ensure error-free operation of the system, the entire system must be bled. This applies in particular to

- Initial commissioning
- After each hose change
- After each cylinder change
- After maintenance work on the unit, hoses or cylinders.

The oil level in the hydraulic unit must always be checked and hydraulic oil topped up if necessary.



Warning

If the hydraulic cylinder is not completely bled, this can lead to uncontrolled and jerky movements.

As a result, people can become trapped and seriously injured.

⇒ Keep clear of moving parts when operating the hydraulic system.

⇒ Regularly bleed the system, as well as when required.



- When topping up the hydraulic oil, all hydraulic cylinders must be completely retracted! Otherwise the unit may overflow.
- The type of oil used should be noted on the unit. Never use different types of oil when topping up.
- Each time before the hydraulic unit is operated, check the rotating field on the rotating field monitor. If the rotary field display is red, switch the phase inverter of the motor protection plug. An incorrect rotation direction can destroy components of the unit.

Flushing and venting the hoses

1. Remove hose covering.



Before every coupling procedure, clean dirt off the quick-couplers and check for signs of damage.

2. Connect the feed and return flow lines of the hydraulic hoses to the plug and bushing of the unit.
3. Couple the two ends of the hoses (plug and bushing) together in order to create a short circuit connection. (Fig. A.06)
4. Start the hydraulic unit and operate the hand valve of the corresponding hose for approx. 1 min in one direction.
5. Decouple both ends again.
6. Bleed additional lines in the same way.



Fig. A.05

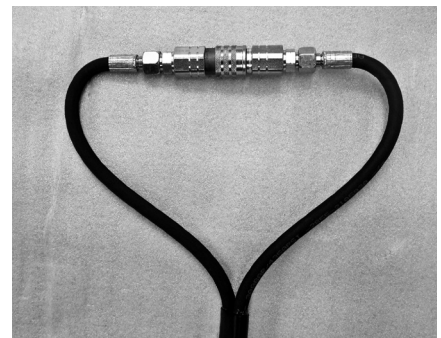

Fig. A.06

Bleeding the cylinder

Before starting the bleeding procedure, all hydraulic cylinders must be completely retracted.

→ If not: connect the hoses to the cylinder, retract the cylinder completely and then flush the hoses again (see "Flushing and venting the hoses" on page 27).



When all cylinders are fully retracted, the hydraulic oil level must be at maximum before bleeding (and filling, if necessary) the cylinders.

1. Position the cylinder horizontally with the connections facing upwards, and secure against rolling away.
2. Couple the hydraulic hoses to create a short-circuit connection, and rinse. See "Flushing and venting the hoses" on page 27.
3. Connect the hydraulic hoses to the unit and cylinder.
4. Start the hydraulic unit, operate the hand valve and extend the cylinder completely.
 - ⇒ The air pockets on the rod side are displaced.
5. Switch off the hydraulic unit, briefly operate the hand valve and relieve the pressure in the hose.
6. Remove hydraulic hoses from the cylinder, couple to create a short-circuit connection, and rinse. See "Flushing and venting the hoses" on page 27.

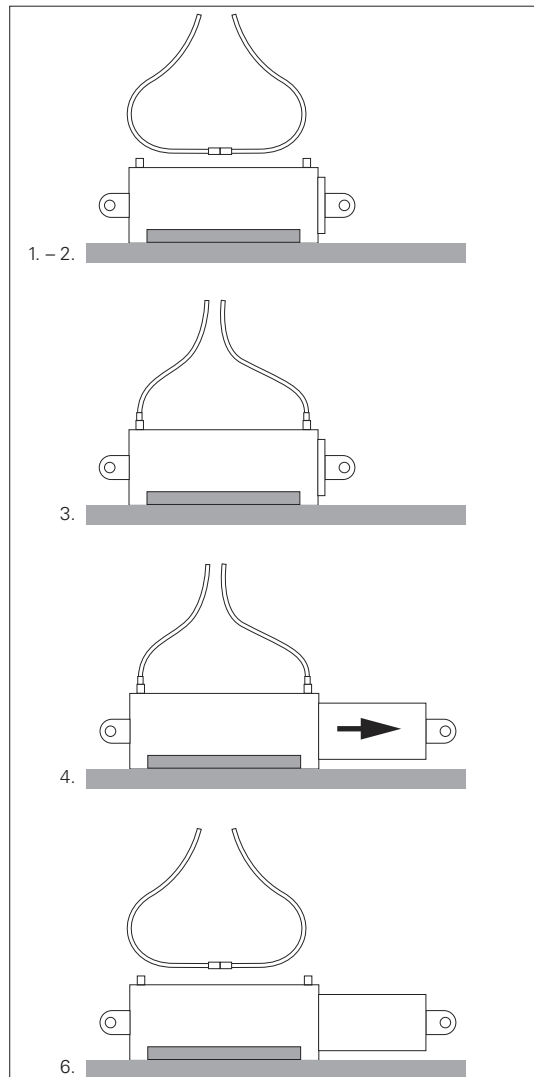

Fig. A.07

7. Connect the hydraulic hoses to the cylinder.
8. Start the hydraulic unit, operate the hand valve and retract the cylinder completely.
→ The air pockets on the floor side are displaced.
9. Switch off the hydraulic unit, briefly operate the hand lever and release the pressure in the hose.
10. Remove hydraulic hoses from the cylinder, couple to create a short-circuit connection, and rinse.
11. Connect the hydraulic hoses to the cylinder.
12. Extend and retract the cylinder several times in order to check the synchronisation. If this is not guaranteed or the cylinder moves jerkily, repeat the complete bleeding procedure.

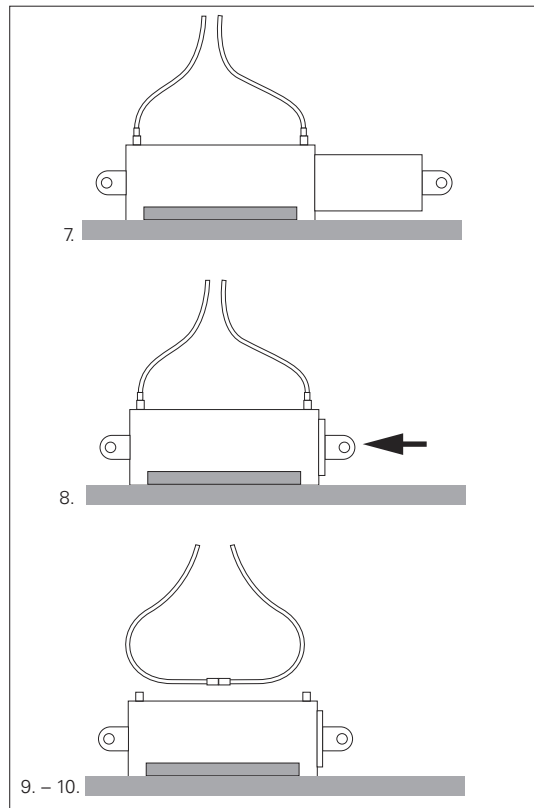

Fig. A.07

A6 Remedial measures for malfunctions

Malfunction	Cause	Remedial measure
Cylinder sinks	Air in the hydraulic system	Vent the system
	Pressure-retaining valve defective	Replace the cylinder. Repairs by PERI
	Seals defective	Replace the cylinder. Repairs by PERI
Uneven cylinder extension and retraction	Air in the hydraulic system	Vent the system
	Dirt in the hydraulic system	Replace hydraulic oil and, if necessary, clean and replace hydraulic tank and oil filter
	Leakage between unit and cylinder	Identify leakage point and seal; replace component if necessary
Hydraulic oil is leaking	Hydraulic hose is broken or leaks	Immediately stop the procedure and replace the hydraulic hose. Check all hydraulic hoses
	Connections not tightened properly	Switch off the hydraulic unit (to relieve pressure). Tighten hose connections

General

The following operating sequence for moving the balanced cantilever equipment describes the standard application.

Deviations are possible due to project-specific requirements.

Detailed information regarding each step is described in the following sections.

The balanced cantilever equipment may only be moved if the brakes are applied.

Standard cycle sequence

The following working operations are described in the respective sections.

Preparation – B2, B3

Release the formwork from the previous concreting section.

Lower the top and bottom slab formwork.

Pushing the rail forward – C2

Release anchoring for the rail.

Raise the rail and gradually push forward with the drive cylinder.

Anchor the rail.

Activating carriages – B4, B5

Activate front carriage.

Activate rear carriage.

Moving the balanced cantilever equipment forward – C1

Gradually move the balanced cantilever equipment forward with the drive cylinder.

Deactivating carriage – B4, B5

Deactivate rear carriage.

Deactivate front carriage.

Subsequent work – B2,B3

Raise the top and bottom slab formwork and anchor.

Set up the vertical formwork.

Install reinforcement.

Concreting

Concrete the next section.

General

Height adjustment

The height of the front suspension of the slab formwork is adjusted using the pre-tensioning jack and hand pump in the same way as described below.

Anchoring

Release the anchoring, e.g. for slab formwork, bottom slab formwork, parapet formwork, according to project-specific documentation.



Warning

Incorrect operation or hydraulic damage can cause unforeseen movements of the components.

As a result, body parts could become trapped and crushed.

- ⇒ While the domed nut is being fitted, no other work is to be carried out on the anchoring.
- ⇒ Do not change the switch status of the hydraulic system.
- ⇒ Do not insert hands between clamping points.



- Do not exceed the permissible pre-tensioning force for each respective tie rod. See table. B2.01
- Follow Instructions for Use from the hand pump manufacturer!

Pressure conversion

Valid for EUROPRESS cylinder CMF60N75 (art. no.: 132249)

Pre-tensioning force [kN]	Pre-tensioning jack pressure [bar]
50	59
100	119
150	178
200	237
250	297
300	356
350	415
400	475
450	534
500	593
550	653
590	700

Tab. B2.01

Lowering the anchoring

All illustrations are examples only, other mounting situations are possible.

Components

- 6** Pre-Tensioning Jack-2 VBC
- 7** Hand Pump-2 VBC
- 9** Chuck VBC
- 29** Sliding Plate VBC
- 62** Domed nut

Lowering procedure

1. Place chuck (9), pre-tensioning jack (6) and sliding plate (29a) over the tie rod.
2. Extend pre-tensioning jack with the hand pump (7) by the required lowering dimension. Do not completely extend the pre-tensioning jack. Approx. 1 cm residual stroke must be left.
3. Screw upper domed nut (62a) onto the tie rod until it rests against the sliding plate (29).
4. Extend the pre-tensioning jack further and slightly raise the tie rod. Do not exceed the pre-tensioning force. See table B2.01.
→ The domed nut (62b) is relieved and can be operated.
5. Raise the bottom domed nut (62b).
6. Retract the pre-tensioning jack and continue to raise the bottom domed nut (62b).
→ The slab formwork is lowered.
7. Lift the domed nut (62a), sliding plate (29a), pre-tensioning jack (6) and chuck (9) off the tie rod.

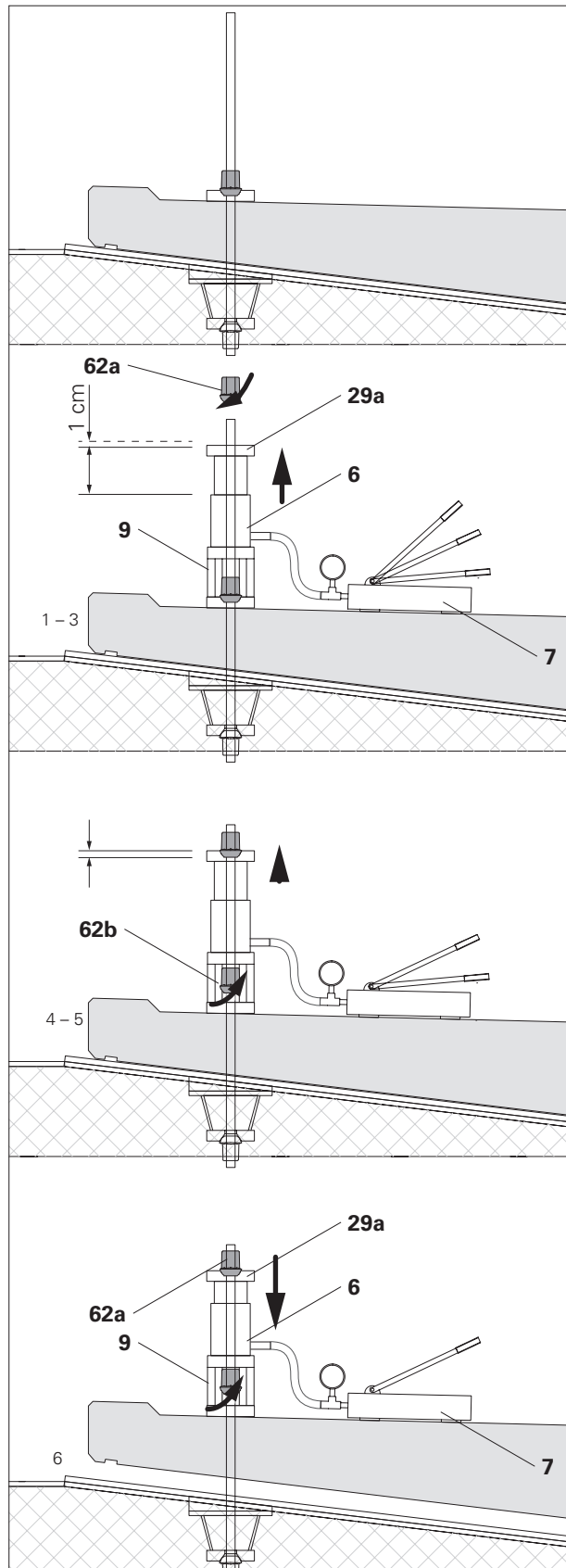

Fig. B2.01

Raising the anchoring

Components

- 6** Pre-Tensioning Jack-2 VBC
- 7** Hand Pump-2 VBC
- 9** Chuck VBC
- 29** Sliding Plate VBC
- 62** Domed Nut D40

Lifting process

1. Place chuck (**9**), pre-tensioning jack (**6**) and sliding plate (**29a**) over the tie rod.
2. Screw domed nut (**62a**) onto the tie rod until it rests against the sliding plate (**29**).
3. Extend the pre-tensioning jack (**6**) with the hand pump (**7**).
4. Turn the bottom domed nut (**62b**) downwards until it rests against the sliding plate (**29a**).
→ The slab formwork is raised.
5. After the last stroke, tighten the bottom domed nut with a wrench. The required tightening torque must be determined on a project-specific basis. Do not exceed the pre-tensioning force. See table B2.01.
6. Retract the pre-tensioning jack.
7. Lift the domed nut (**62a**), sliding plate (**29a**), pre-tensioning jack (**6**) and chuck (**9**) off the tie rod.

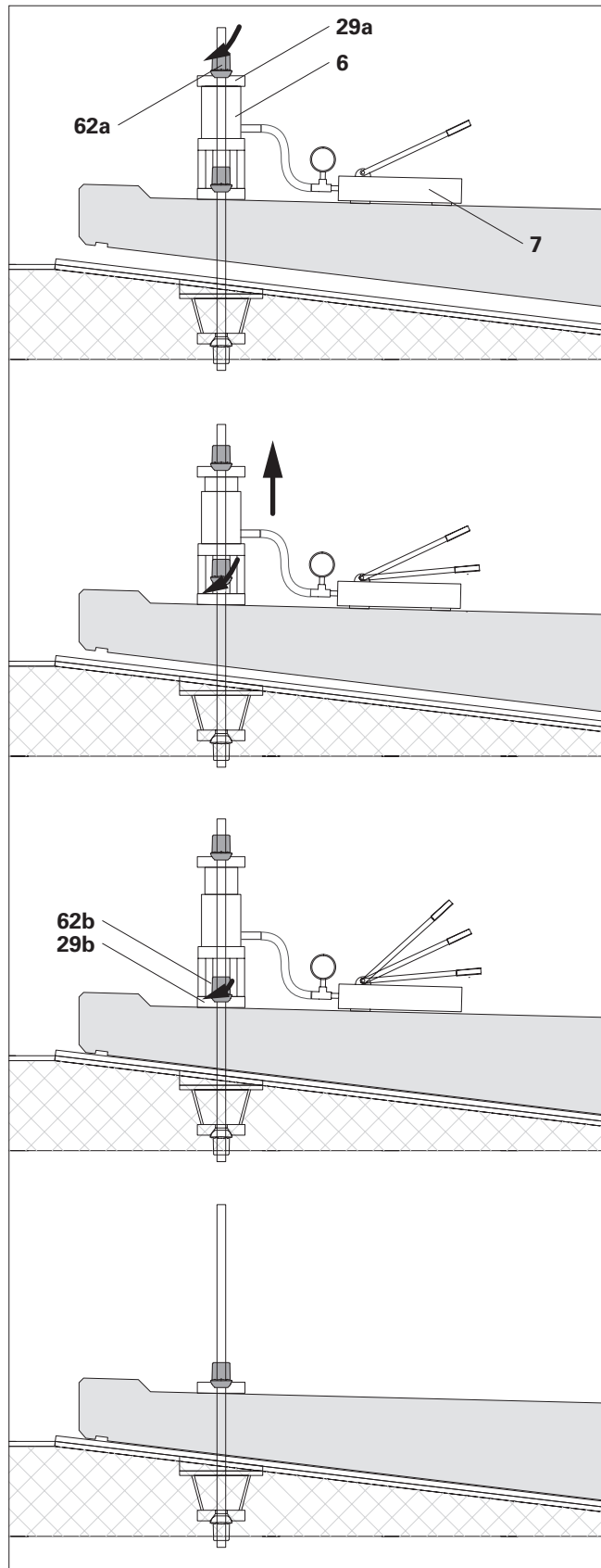

Fig. B2.02

General information



Warning

Incorrect operation or hydraulic damage can cause unforeseen movements of the components.

As a result, body parts could become trapped and crushed.

- ⇒ While the tie nut is being screwed in, no other work is to be carried out on the machine.
- ⇒ Do not change the switch status of the hydraulic system.
- ⇒ Do not place hands between clamping points.



For the lifting and lowering procedure, one person is required per lifting and lowering cylinder.

Lowering the bottom slab formwork

Components

- 5 Lifting and Lowering Cylinder VBC 280
- 10 Cylinder Table VBC
- 33 Lifting Shim VBC 20
- 34 Lifting Jack Bracket VBC
- 35 Lifting Counterplate VBC
- 61 Tie nut straight

Undoing anchoring

Release the anchoring for the bottom slab formwork according to project-specific documentation.

The position of the lifting and lowering cylinder can differ from project to project. However, the lifting and lowering procedure is carried out in the same way. (Fig. B3.01 + B3.02)

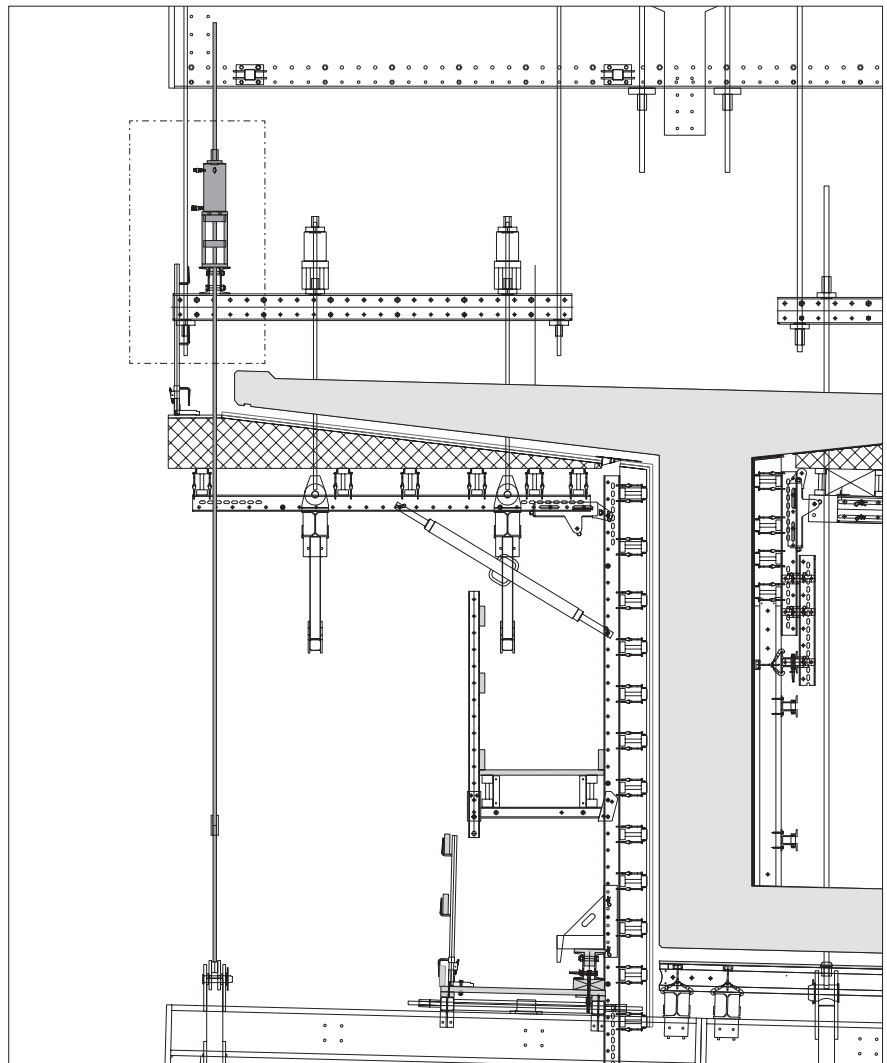

Fig. B3.01

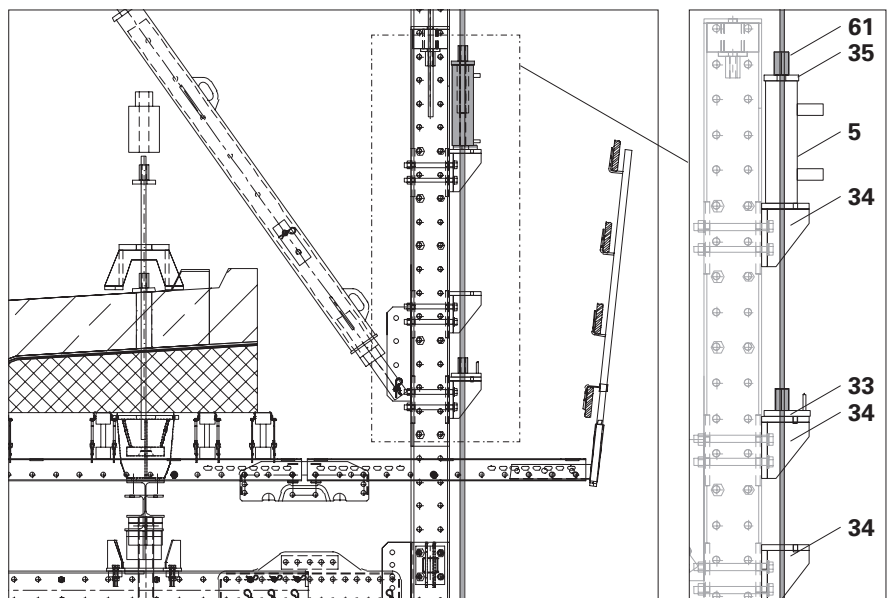

Fig. B3.02



- Carry out the lowering procedure on all 4 suspensions at the same time.
- Maintain constant contact with the operator of the hydraulic unit during the lowering process.

Lowering procedure

1. Raise the upper tie nut (**61a**) by < 25 cm.
2. Completely extend the lifting and lowering cylinder (**5**), thereby slightly raising the tie rod.
3. Raise the lower tie nut (**61b**) by < 25 cm.
4. Retract the lifting and lowering cylinder.
 - The suspension unit is lowered.
 - The bottom tie nut is positioned on the lifting counterplate (**35a**).
 - Some play still remains on the top tie nut (**61a**).
5. Repeat steps 1 to 4 until the required lowering dimension is reached.

(Fig. B3.02 + B3.02a)

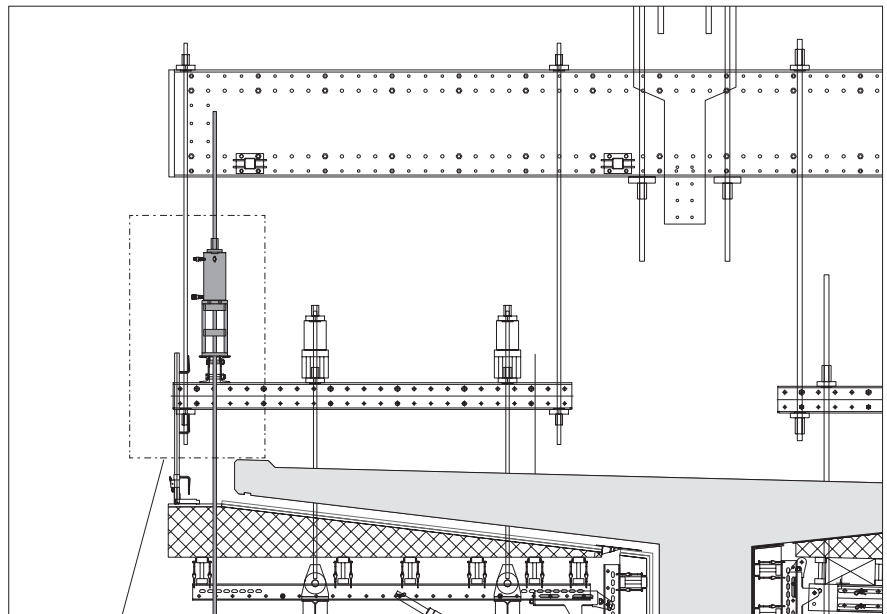

Fig. B3.02

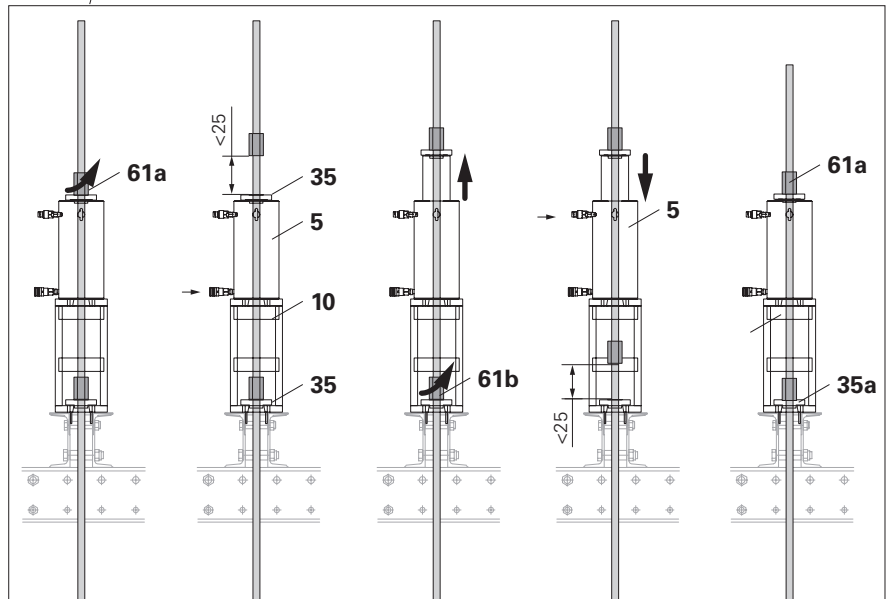

Fig. B3.02a

Raising the bottom slab formwork

Components

- 5** Lifting and Lowering Cylinder VBC 280
- 10** Cylinder Table VBC
- 35** Lifting Counterplate VBC
- 61** Tie nut straight



- Carry out the lifting procedure on all 4 suspensions at the same time.
- Maintain constant contact with the operator of the hydraulic unit during the lifting process.

Lifting process

1. Completely extend the lifting and lowering cylinder (**5**).
→ The suspension unit is raised.
2. Completely lower the bottom tie nut (**61b**) onto the lifting counterplate (**35b**).
3. Completely retract the lifting and lowering cylinder (**5**).
4. Completely screw down the top tie nut (**61a**) onto the lifting counterplate (**35a**).
5. Repeat steps 1 to 4 until the required lowering dimension is reached.
(Fig. B3.03)

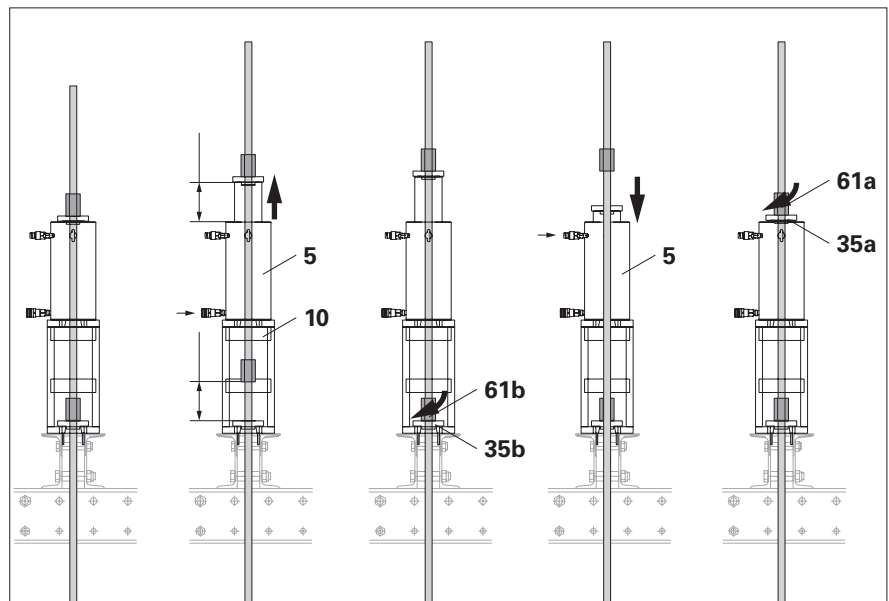

Fig. B3.03

Mounting anchoring

Mount the anchoring for the bottom slab formwork according to project-specific documentation.

General



Warning

Incorrect operation or hydraulic damage can cause unforeseen machine movements.

As a result, body parts could become trapped and crushed.

⇒ Keep your distance from the machine while operating the hydraulic cylinder.



Only raise the front carriage when the mounted brake is engaged in the rail.

Components

- 2** Front Main Cylinder VBC 280
- 8** Rail VBC
- 24** Main Frame Post VBC
- 30** Post Base VBC
- 31** Front Carriage VBC

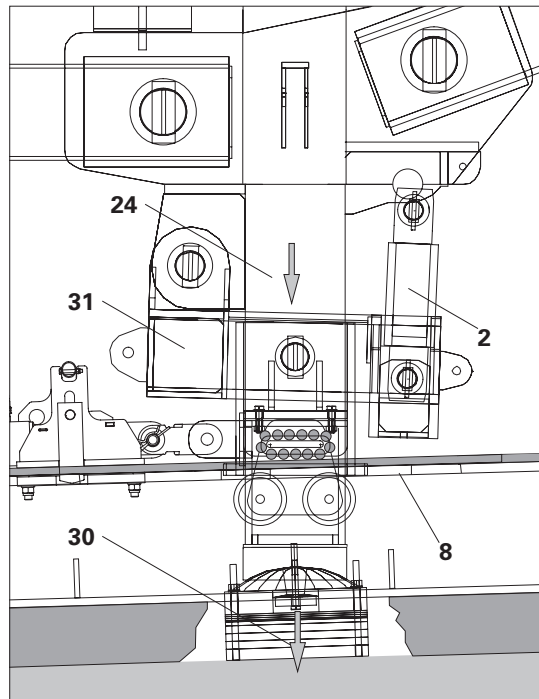

Fig. B4.01



If the front carriage is deactivated, place the front main cylinder in a load-free position, remove bolts at the top and completely retract. As a result, the piston rod is protected against corrosion and damage.

To activate the chassis, extend the front main cylinder accordingly and bolt in place.

Force progression during operation

The support load is transferred from the main frame post (**24**) into the structure via the post base (**30**). (Fig. B4.01)

Force progression in drive mode

The support load is transferred from the main frame post (**24**) to the rail (**8**) via the front carriage (**31**) and the roller bearings (**31.1**). The post base (**30**) is free of any load. (Fig. B4.02)

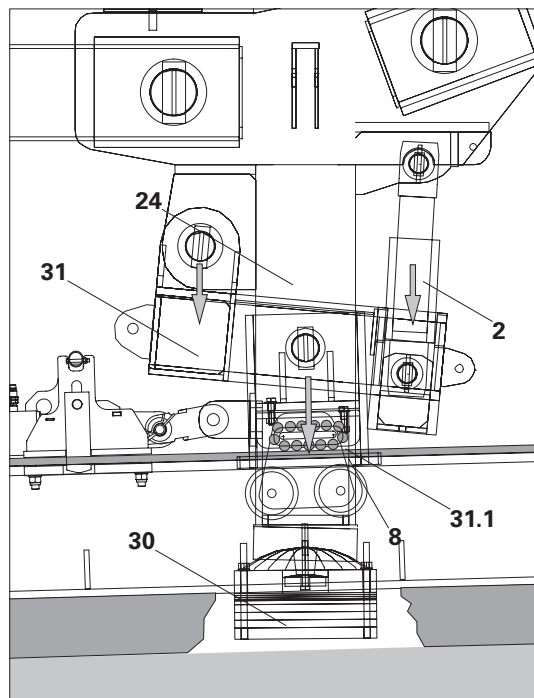

Fig. B4.02

Activating front carriage

- Carriage is in a supported position = operational mode.
- Brake is activated.

1. Extend the front main cylinder (2).
- Front carriage (31) moves downwards until the roller bearing (31.1) is positioned on the rail (8). (Fig. B4.03)
- Front main cylinder raises the main frame post (24) with post base (30) when extended further. (Fig. B4.04)
- Cantilever frame moves upwards accordingly.
- Front carriage is in drive mode. (Fig. B4.05)

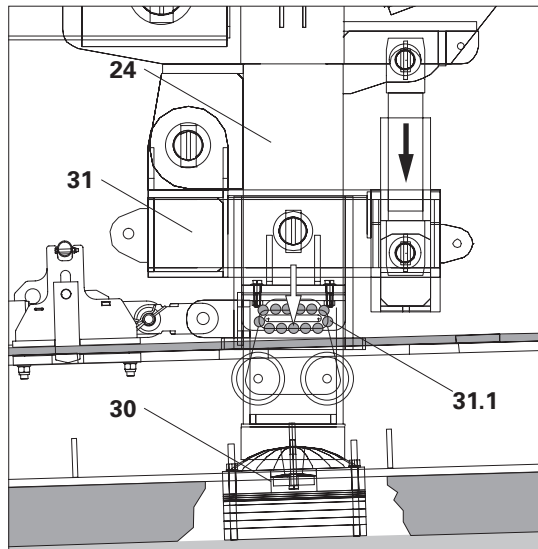

Fig. B4.03

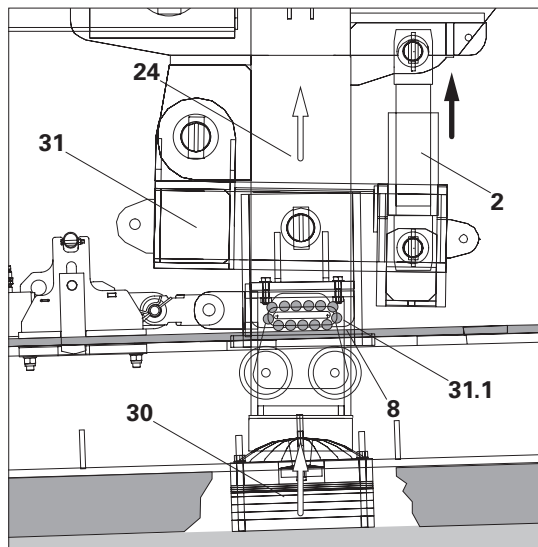

Fig. B4.04

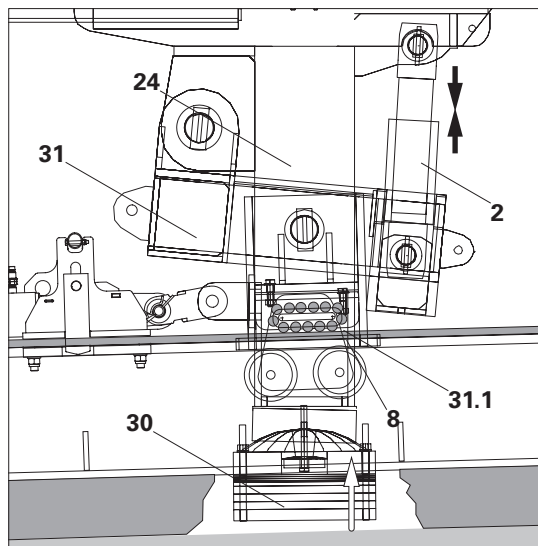

Fig. B4.05

Deactivating front carriage

→ Carriage is in a raised position
= drive mode.

1. Retract the front main cylinder (2).
- The front main cylinder lowers the main frame post (24) until the post base (30) rests on the structure.
(Fig. B4.06 + B4.07)
- Cantilever frame moves downwards accordingly.
- The front carriage (31) moves upwards through further retraction until the roller bearing (31.1) is lifted away from the rail (8). (Fig. B4.08)
- The front carriage is in operational mode.

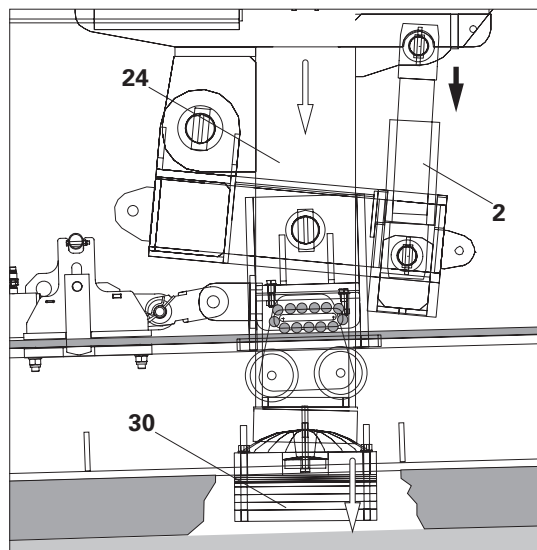

Fig. B4.06

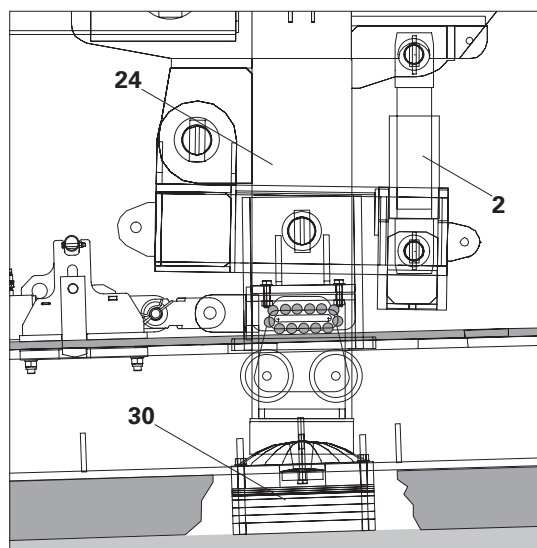

Fig. B4.07

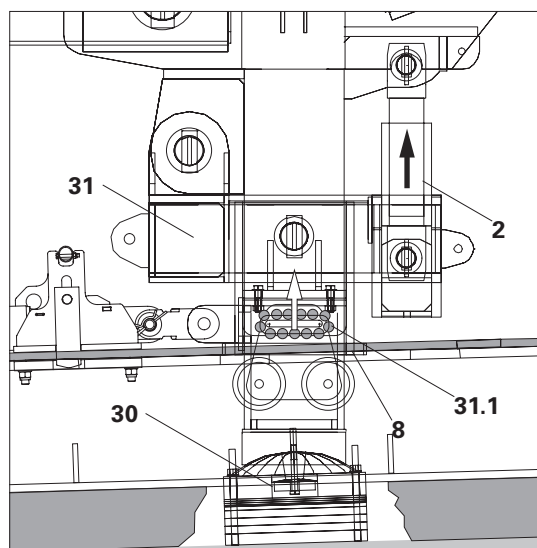

Fig. B4.08

General



Danger

The rear carriage as well as the rail are subjected to high lifting forces.

If connecting elements are improperly released, this can lead to sudden lifting of the rear carriage or rail and cause the balanced cantilever equipment to crash.

- ⇒ Only open the connecting elements if the person in charge has given the go-ahead.
- ⇒ Attach markings for the required screw-in depth on all tie rods which are connected by means of hexagonal couplers, and take this into consideration when fastening.



Warning

Incorrect operation or hydraulic damage can cause unforeseen machine movements.

As a result, body parts could become trapped and crushed.

- ⇒ Keep your distance from the machine while operating the hydraulic cylinder.
- ⇒ While the tie rods are being removed or installed, no other work is to be carried out on the machine.
- ⇒ Do not change the switch status of the hydraulic system.
- ⇒ Do not place hands between clamping points.

Components:

- 4 Rear Main Cylinder VBC 280
- 8 Rail VBC
- 23 Main Frame Chord VBC
- 25 Rear Carriage Tube VBC
- 26 Rear Carriage Rocker VBC
- 27 Rear Carriage Head VBC
- 28 Hold-down Bracket VBC
- 29 Sliding Plate VBC
- 32 Head Pawl Pin VBC
- 36 Roller Block VBC
- 51 Auxiliary tie rod
- 52 Anchor tie rod
- 53 Main tie rod
- 61 Auxiliary tie nut
- 62 Domed nut
- 63 Main tie nut
- 64 Hexagonal coupler

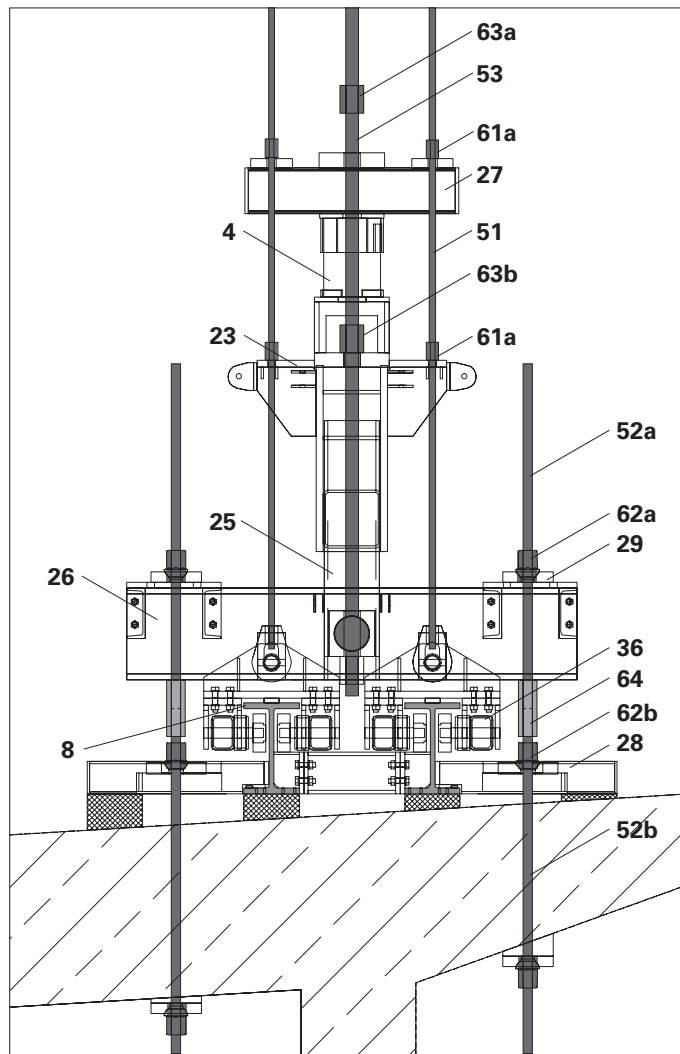

Activating rear carriage

→ Carriage is in an anchored position
= operational mode.

Force progression during operation

The lifting forces from the main frame chord (**23**) are transferred to the main tie rod (**53**) via the main tie nut (**63b**). At the yoke pin (**26.1**), the force is transferred to the rear carriage rocker (**26**).

The rear carriage rocker carries the force to the anchor tie rods (**52**) which then transfer the force into the structure.

Step 1

1. Loosen the top main tie nut (**63a**) in order to create space. In this position, the main tie nut has no supporting function.
2. Position the auxiliary tie nuts (**61**) on the rear cylinder head, do not tighten.

(Fig. B5.01)

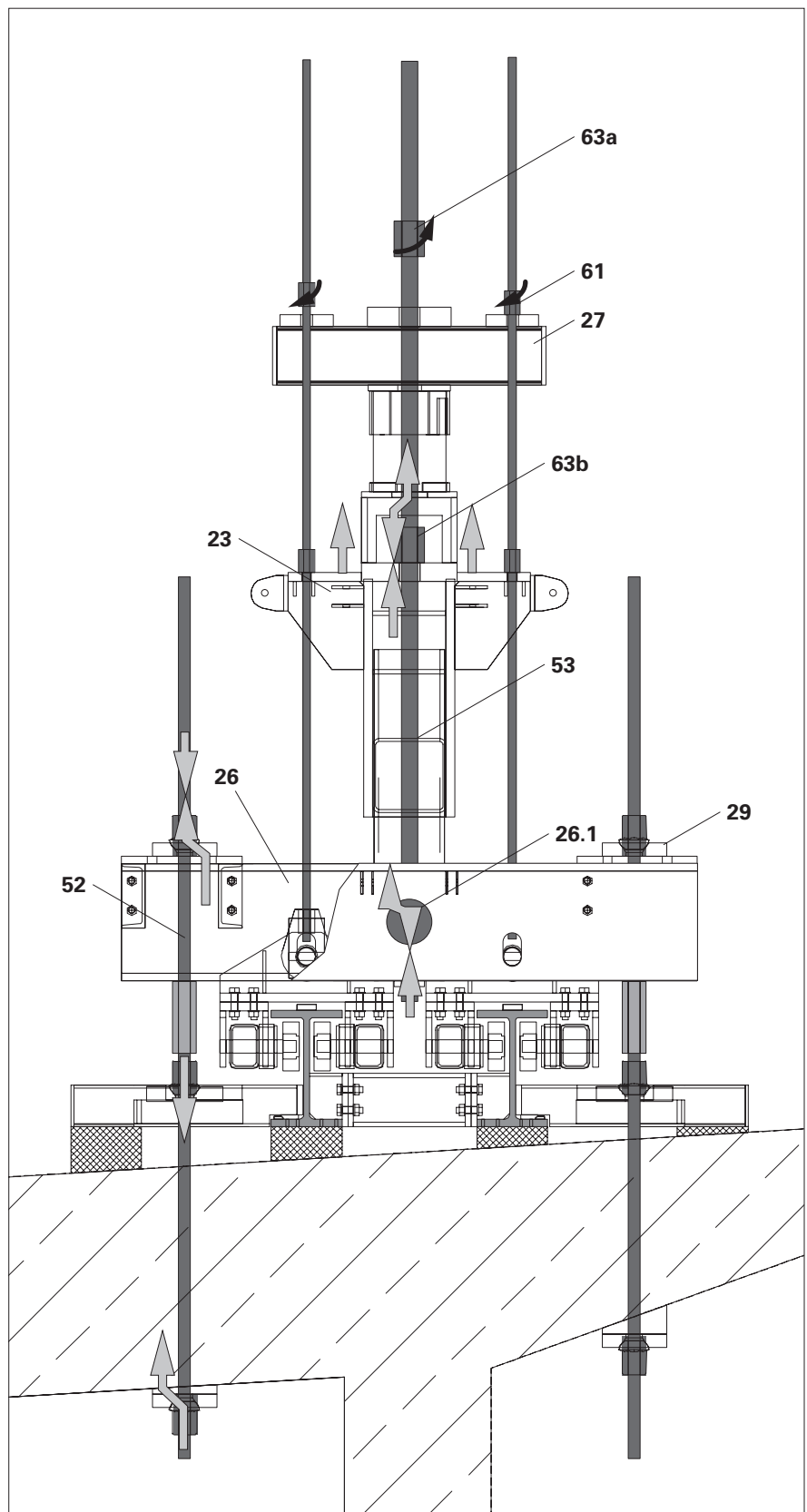

Fig. B5.01

Step 2

1. Extend the rear main cylinder (4) approx. 50 mm.
 - The rear cylinder head (27) is pressed upwards and pulls the roller blocks (36) against the rail (8).
 - The rear carriage tube (25) is pressed downwards with the rear carriage rocker (26) against the lifting force.
 - Cantilever frame moves upwards accordingly.
 - The rear carriage is in a load-transfer state.
 - Clearance is created on the domed nuts (62).
2. Screw down the auxiliary tie nuts (61) until they rest against the main frame chord (23).
 - The rear carriage rocker is secured in the bottom position.

(Fig. B5.02)

Force progression in a load-transfer state

The lifting force from the main frame chord is transferred to the rail (8) via auxiliary tie rods (51) and roller blocks (36).

The hold-down brackets (28) carry the force to the anchor tie rods (52) which then transfer the force into the structure.

(Fig. B5.02)

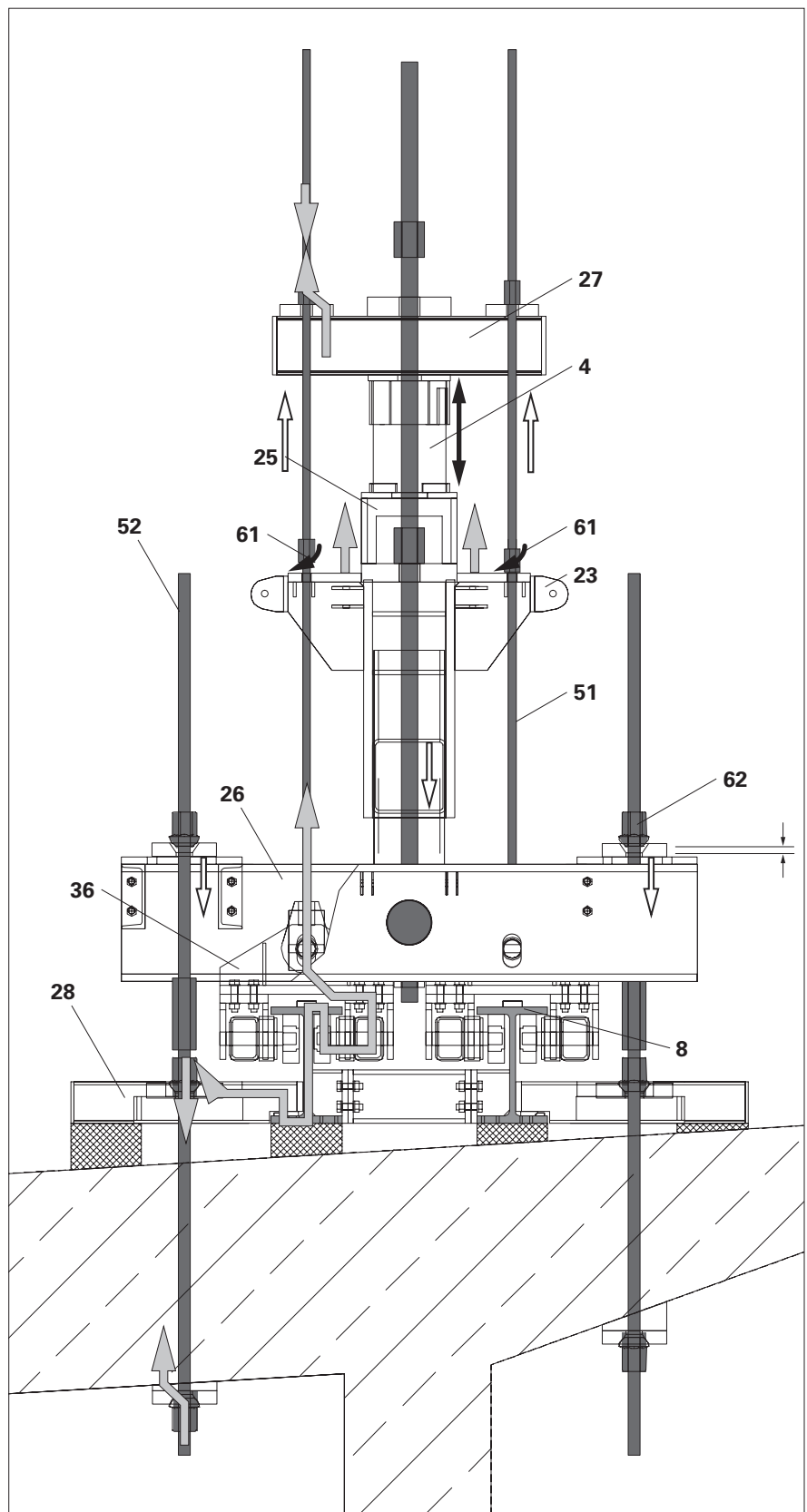

Fig. B5.02

Step 3

1. Release the upper domed nuts (**62**).
 2. Screw out the upper anchor tie rods (**52**) from the hexagonal coupler (**64**) and lay to one side.
 3. Remove the hexagonal coupler and lay to one side.
- (Fig. B5.03)

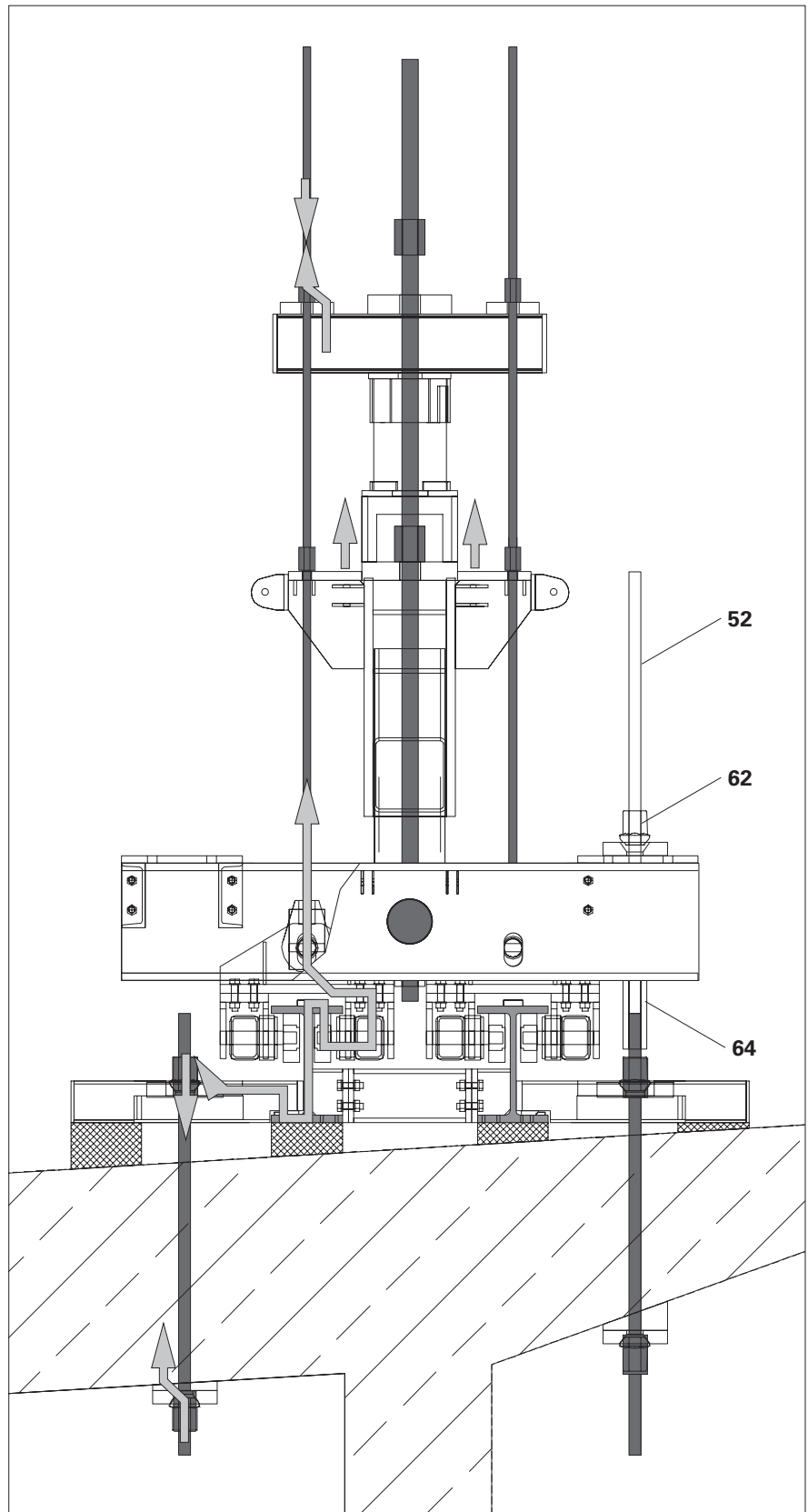

Fig. B5.03

Step 4

1. Loosen the bottom auxiliary tie nuts (61a) and screw upwards approx. 10 cm.
2. Retract the rear main cylinder (4).
 - The rear cylinder head (27) is held in position through the auxiliary tie rods (51) and roller blocks (36).
 - Rear carriage tube (25) and rear carriage rocker (26) move upwards until the lower edge of the slot rests on the head pawl pin (32).
 - Cantilever frame moves downwards accordingly.
 - The rear carriage is in drive mode.
3. Screw the top auxiliary tie nuts (61b) upwards a few turns.

(Fig. B5.04)

Force progression in drive mode

The lifting force from the main frame chord is transferred to the yoke pin (26.1) via the main tie rod (53) and then from there to the rear carriage rocker (26).

The rear carriage rocker transfers the force to the roller blocks (36) via the head pawl pins (32). The roller blocks transfer the force into the structure via the rail, hold-down bracket and the bottom anchor tie rods.

(Fig. B5.04)

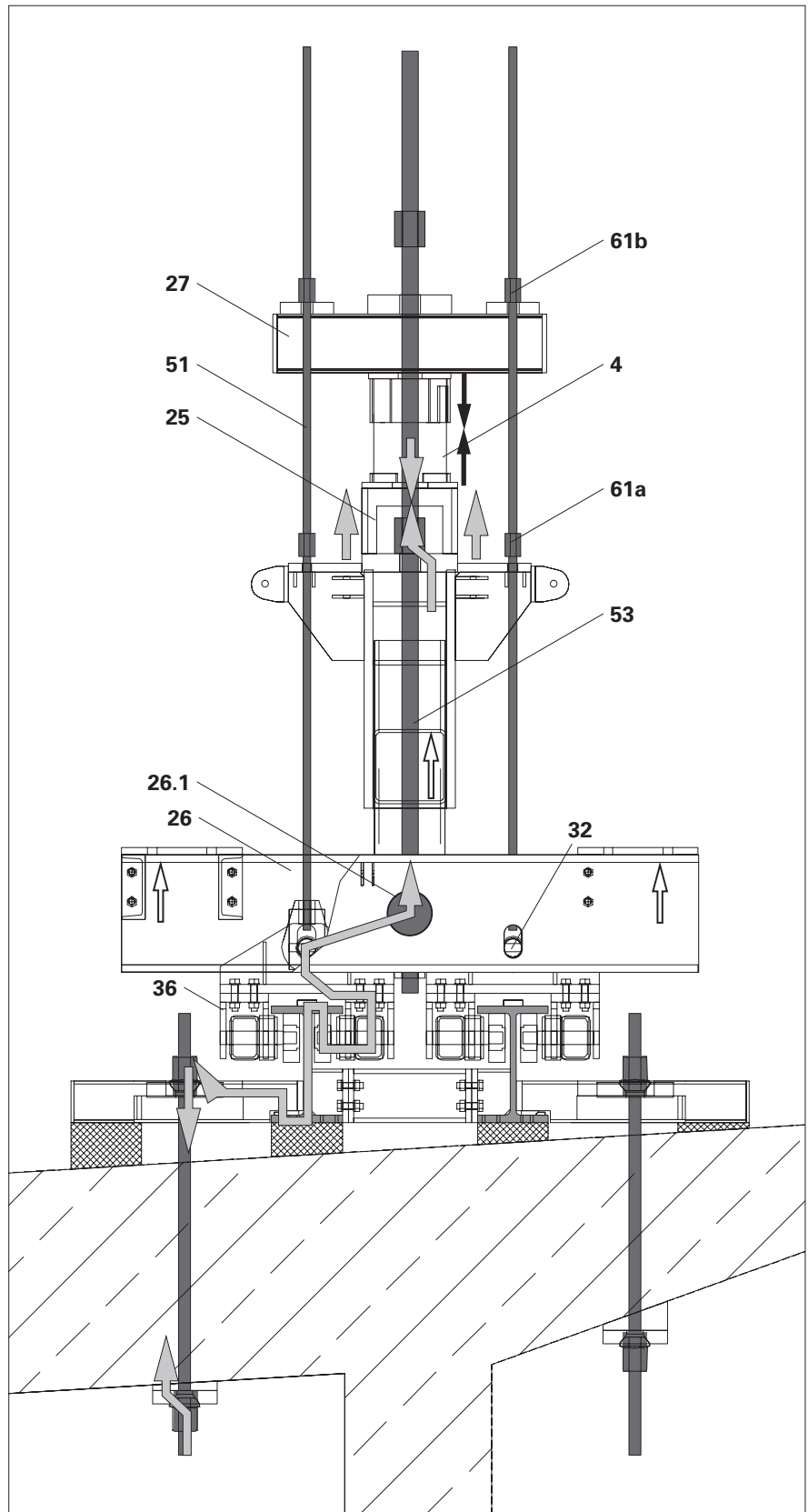

Fig. B5.04

Deactivating the rear carriage

- The carriage is in drive mode.
- The carriage is centred over the anchoring and hold-down brackets.

Force progression in drive mode

See "Step 4" on page 48.

Step 1

1. Loosen the main tie nut (63) in order to create space. In this position, the main anchor tie nut (63) has no supporting function.
2. Position the auxiliary tie nuts (61a) on the rear cylinder head (27), do not tighten.

(Fig. B5.05)

Step 2

1. Extend the rear main cylinder (4) approx. 50 mm.
 - The rear carriage tube (25) is pressed downwards with the rear carriage rocker (26) against the lifting force.
 - Cantilever frame moves upwards accordingly.
 - The rear carriage is in a load-transfer state.
2. Screw down the auxiliary anchor tie nuts (61b) until they rest against the main frame chord (23).
 - The rear carriage rocker (26) is secured in the bottom position.

(Fig. B5.05)

Force progression in a load-transfer state

See "Step 2" on page 46.

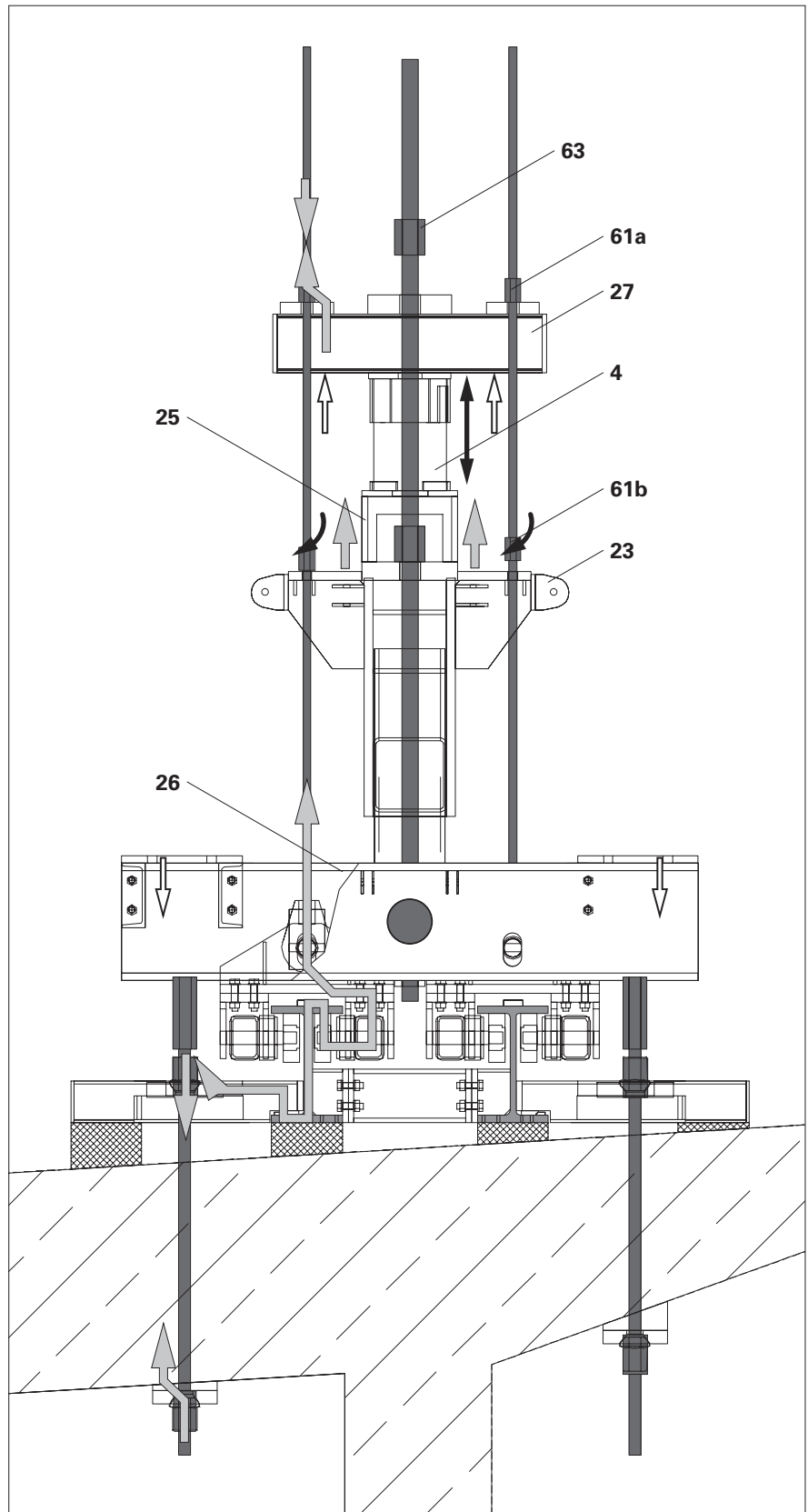

Fig. B5.05

Step 3

1. Screw the hexagonal coupler (64) onto the bottom anchor tie rods (52a) up to the middle of the coupler.
2. Insert top anchor tie rods (52b) through the rear carriage rocker (26) and screw firmly into the hexagonal coupler.



- The tie rod must be screwed in up to the middle of the coupler.
- Take markings for the screw-in depth into consideration!

3. Tighten the top domed nuts (62) on the top anchor tie rod until the domed nuts rest against the rear carriage rocker (26).

(Fig. B5.06)

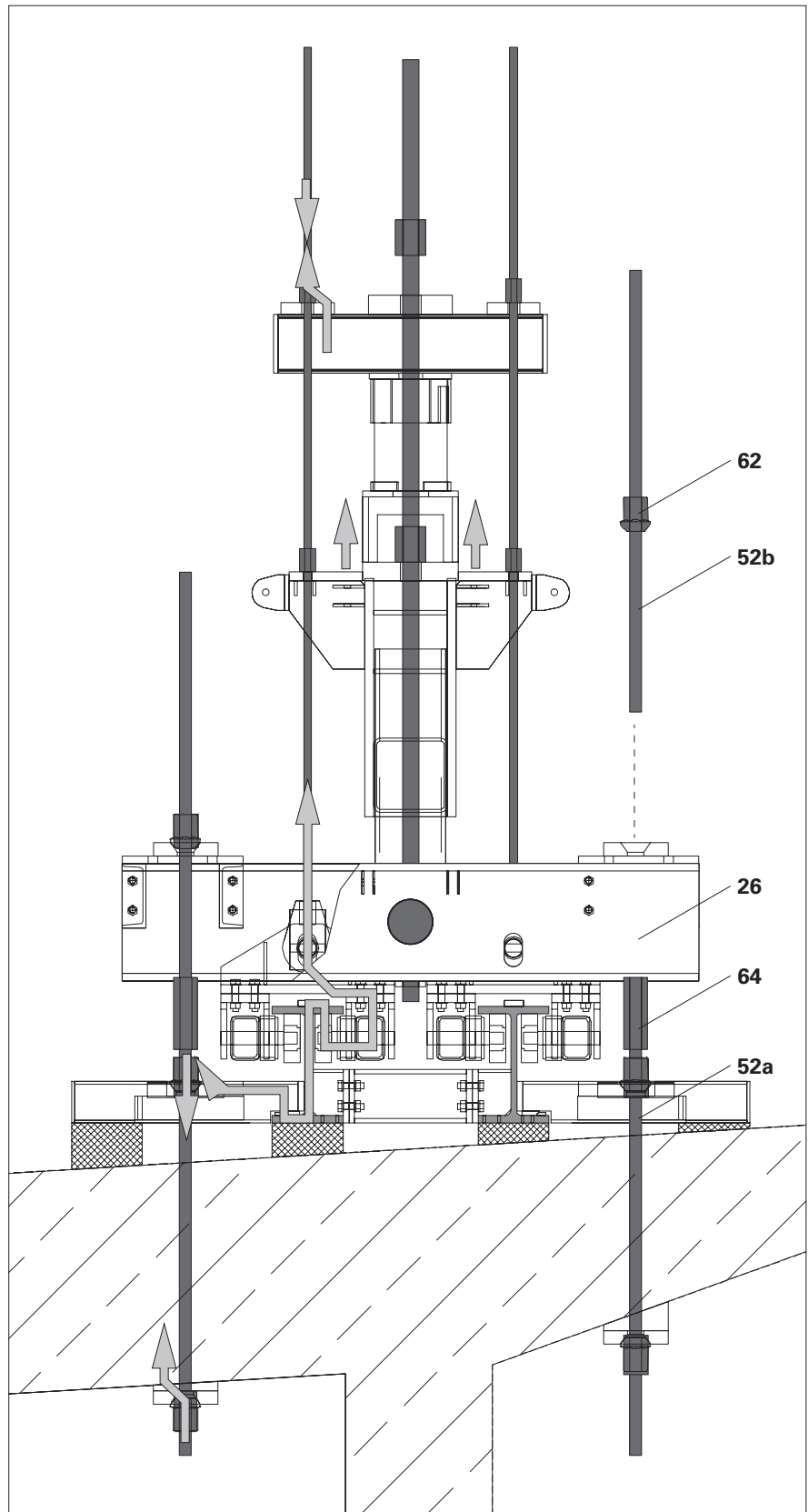

Fig. B5.06

Step 4

1. Loosen the bottom auxiliary tie nuts (61b) and screw upwards approx. 10 cm.
2. Retract the rear main cylinder (4).
 - Anchor tie rods (52) are subject to tensile stress and keep the machine operational.
 - The rear cylinder head (27) is lowered and the roller blocks (36) are lowered from the rail (8).
 - Cantilever frame moves downwards accordingly.
 - The rear carriage is in operational mode.

(Fig. B5.07)

Force progression during operation

See "Activating rear carriage" on page 45.

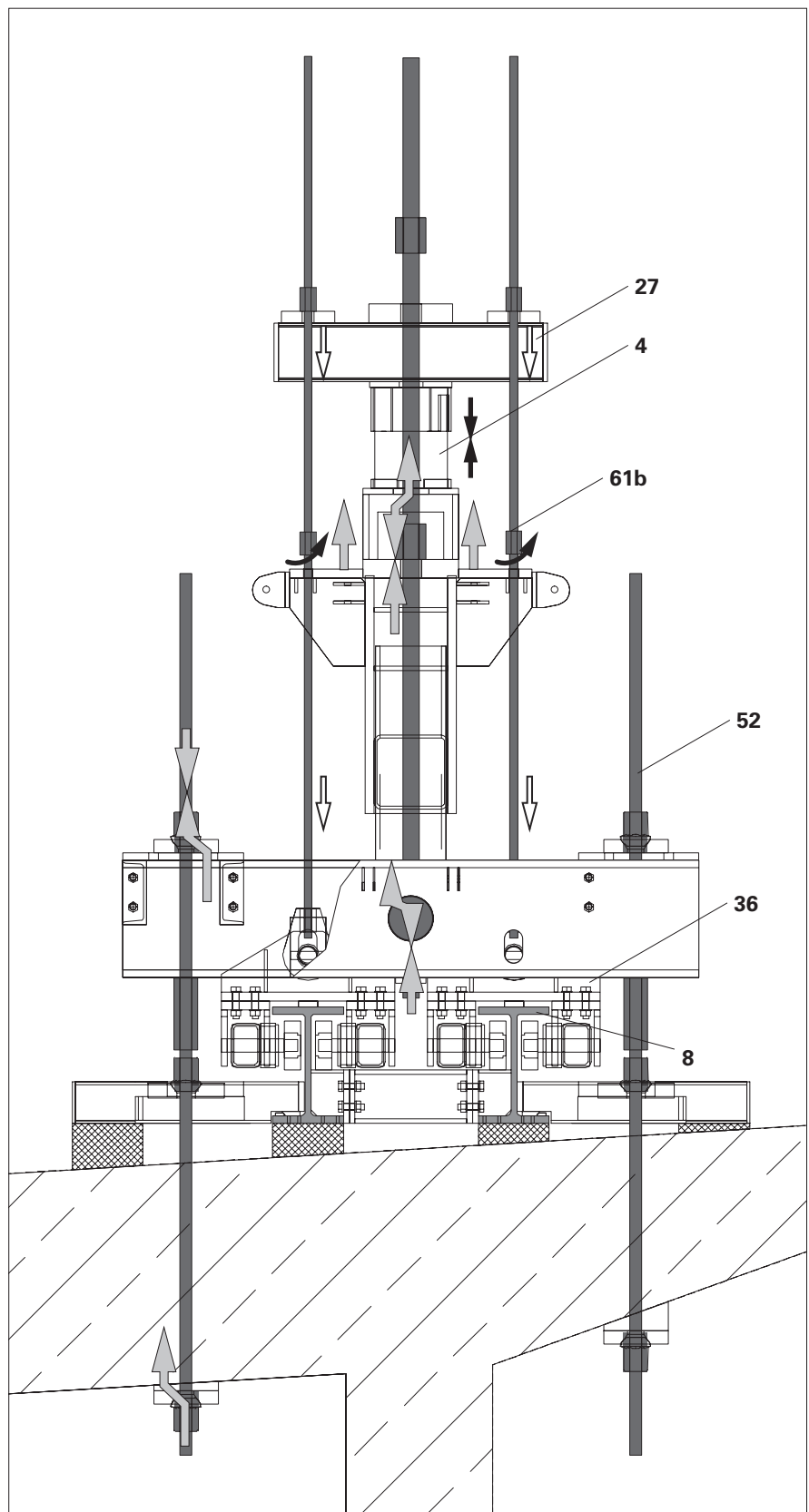

Fig. B5.07

General

Components:

- 3** Driving cylinder
- 8** Rail VBC
- 21** Drive Catch Head-2 VBC

The balanced cantilever equipment is always moved or locked in a controlled manner by two independent drive catch heads (**21**).

The two drive catch heads are identical in construction and function.

The drive catch head (**21B**) is mounted to the main frame column with the coupling rod (**21.3**).

The drive catch head (**21A**) is connected to drive catch head (**21B**) via the drive cylinder (**3**). (Fig. C1.01 + C1.02)

The braking effect of the drive catch heads is achieved by the locking plates (**21.1**) locking into place in the rail.

With the release lever (**21.2**) the locking plates are lifted out, thereby releasing the brake. (Fig. C1.01a)

Warning

Incorrect operation or hydraulic damage can cause unforeseen machine movements.

As a result, body parts could become trapped and crushed.

- ⇒ Keep clear of the machine when operating the hydraulic cylinder and only use the release lever.
- ⇒ Keep all body parts away from under the rail.
- ⇒ Only operating personnel are allowed to remain in the danger zone.

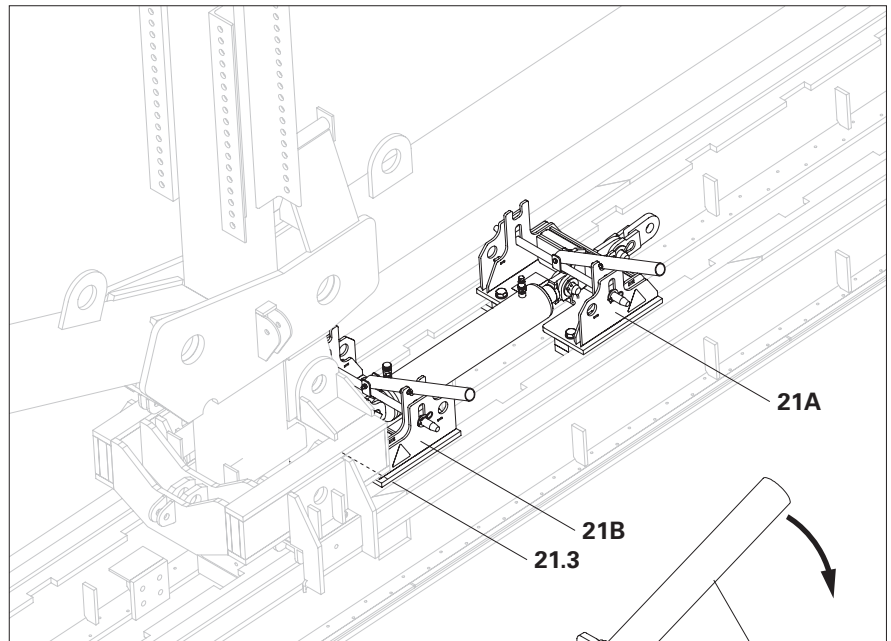

Fig. C1.01

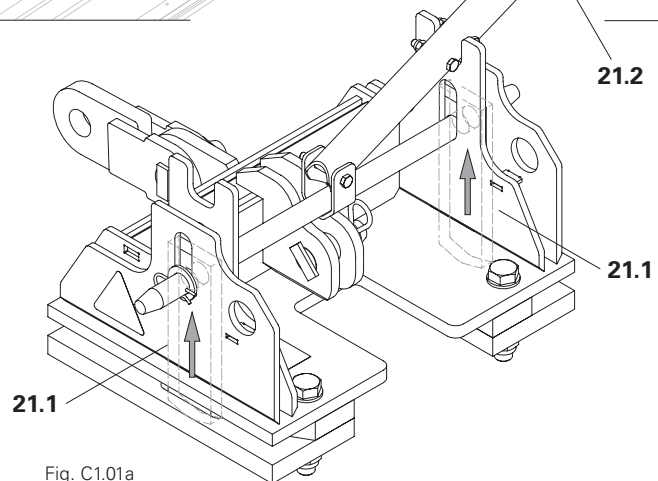

Fig. C1.01a

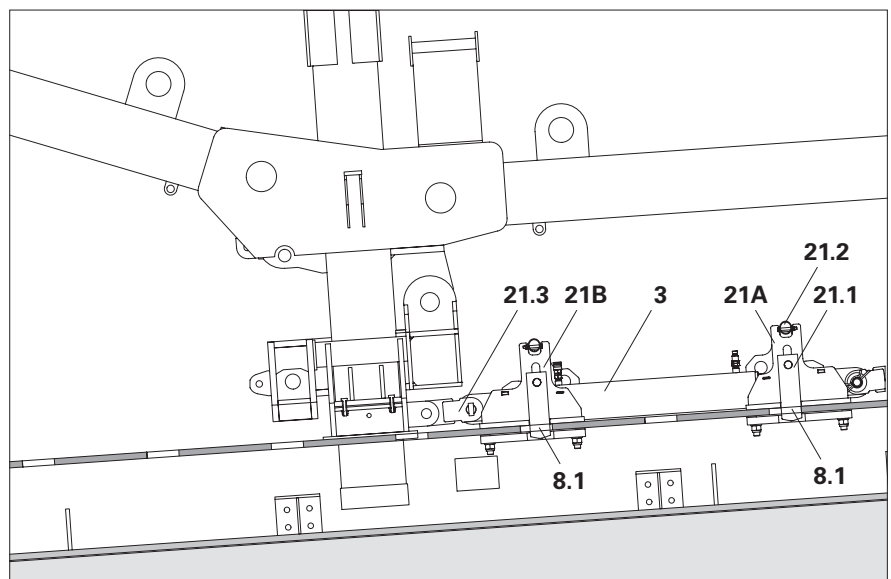

Fig. C1.02

Moving the balanced cantilever equipment forward

Requirements

- Driving cylinder is retracted.
- Locking plates of both drive catch heads are engaged in a section of the rail.
- The entire unit has been put into drive mode:
 - All formwork elements have been released,
 - All loose objects have been removed or secured,
 - The front and rear chassis are activated.

(Fig. C1.02)

Drive mode

1. Press the release lever (21.2) of drive catch head (21B) downwards, thereby lifting the locking plate (21.1).
2. Extend the drive cylinder (3) until the next section of rail (8.1). After leaving the previous section of rail, the release lever can then be released.
 - The balanced cantilever equipment and drive catch head (21B) are moved forward. (Fig. C1.03)

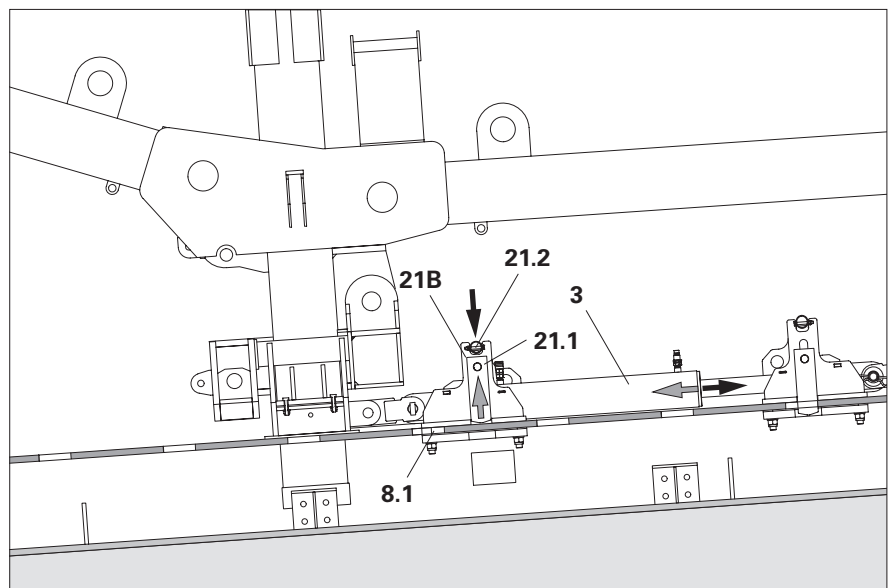

Fig. C1.03

→ The locking plate (21.1) of drive catch head (21B) drops into the next section (8.1) of the rail. (Fig. C1.04)

3. Stop the drive cylinder from extending any further.

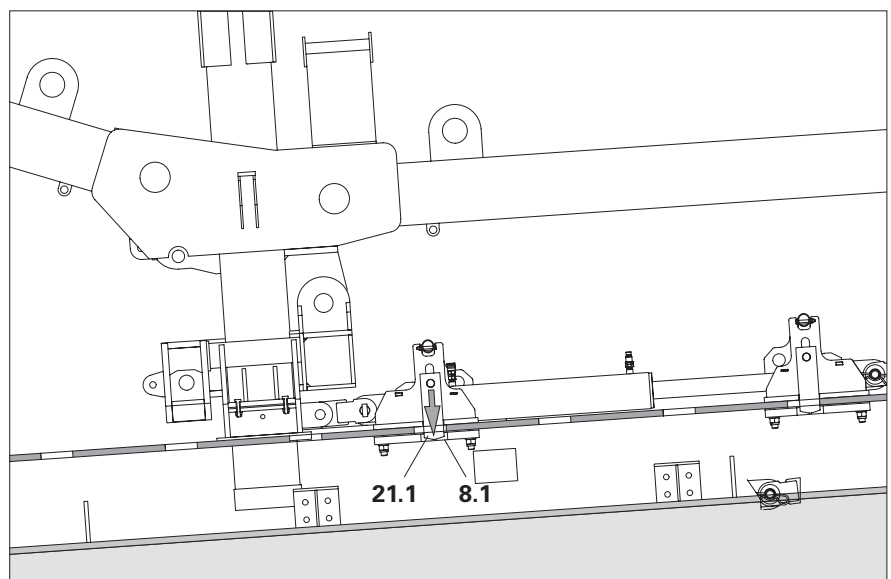

Fig. C1.04

4. Press the release lever (**21.2**) of the drive catch head (**21A**) downwards, thereby lifting the locking plate (**21.1**). (Fig. C1.05)

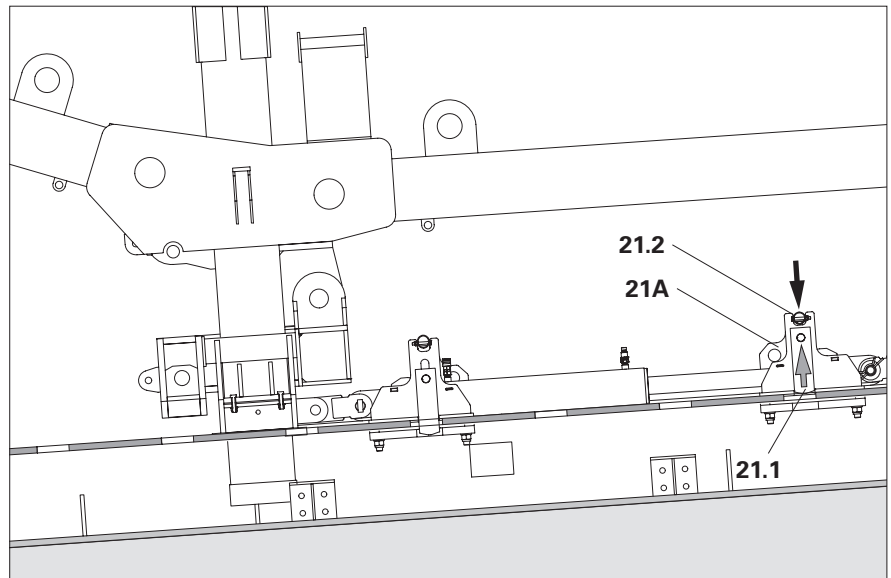

Fig. C1.05

5. Retract the drive cylinder (**3**) to the next section of rail (**8.1**). After leaving the previous section of rail, the release lever can then be released.
 - The balanced cantilever equipment is held securely by the drive catch head (**21B**).
 - The drive catch head (**21A**) is pulled forward. (Fig. C1.06)

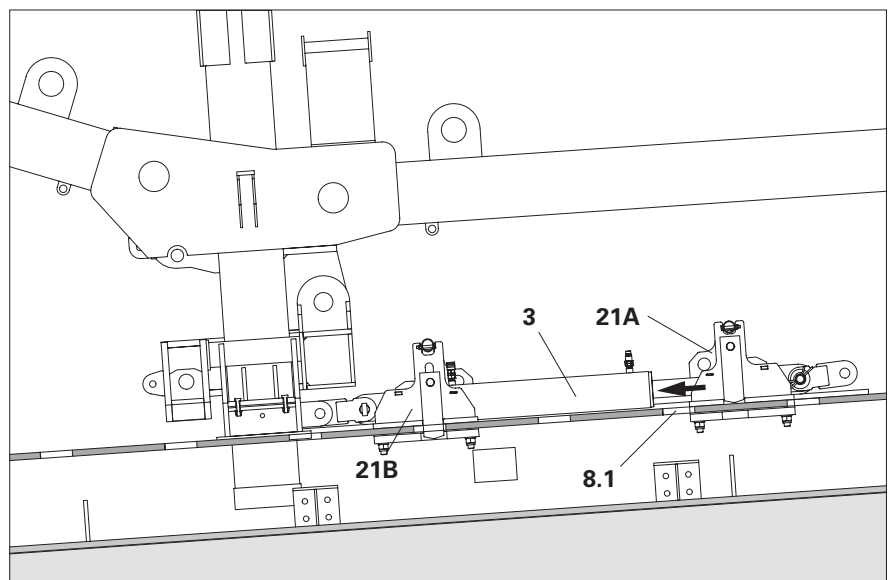

Fig. C1.06

- The locking plate (21.1) of the drive catch head (21A) drops into the next section (8.1) of the rail. (Fig. C1.07)
- 6. Stop the drive cylinder from retracting any further.
- 7. Repeat steps 1 to 6 until the balanced cantilever equipment has reached the next concreting section.
 - The central axis of the main frame post is normally positioned 30 cm in front of the next concreting section.
 - The rear chassis is over an anchoring point.
- 8. Deactivate the carriage of the balanced cantilever equipment, see "Deactivating front carriage" on page 42 and "Deactivating the rear carriage" on page 49.

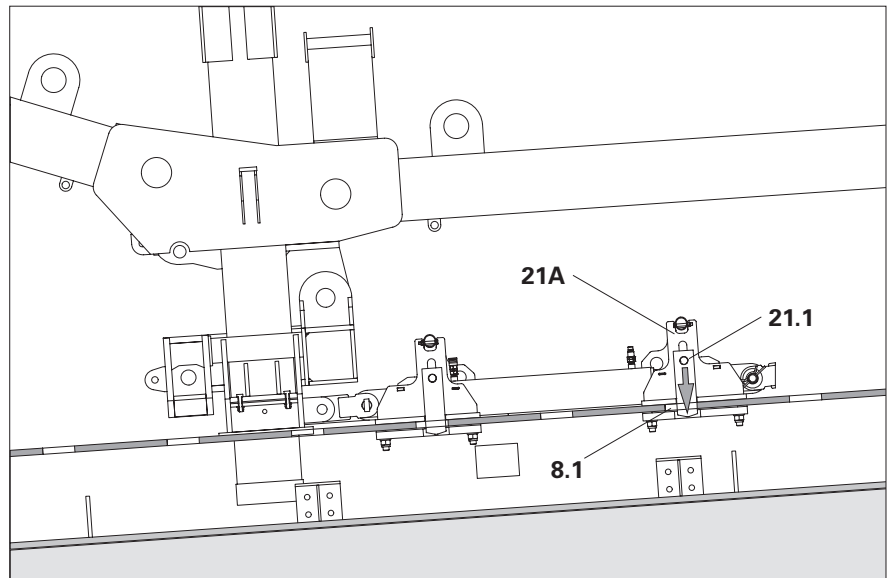

Fig. C1.07



If the locking plate cannot be raised because it is pressed against the section of rail, then briefly move the drive cylinder in the opposite direction.

Subsequent work

Anchoring that is no longer required for the rear carriage is to be moved forwards. Take into account the project-specific documentation.

General



Danger

The rear carriage as well as the rail are subjected to high lifting forces.

If connecting elements are improperly released, this can lead to sudden lifting of the rear carriage or rail and cause the balanced cantilever equipment to crash.

- ⇒ Only open the connecting elements if the person in charge has given the go-ahead.
- ⇒ Attach markings for the required screw-in depth on all tie rods which are connected by means of hexagonal couplers, and take this into consideration when fastening.



Warning

Incorrect operation or hydraulic damage can cause unforeseen machine movements.

As a result, body parts could become trapped and crushed.

- ⇒ Keep your distance from the machine while operating the hydraulic cylinder.
- ⇒ Do not change the switch status of the hydraulic system while working on the machine.
- ⇒ Do not place hands between clamping points.

Requirements

- The pre-cast bridge section must have sufficient load-bearing capacity.
- Remove all loose components from the rail.
- Remove mounting parts from the rail if these have to pass under the carriages.

Preparations

1. On the rear carriage, release the hold-down brackets (**28**) of the rail. To do this, loosen the bottom domed nuts (**62a**) on the bottom anchor tie rod (**52a**) and turn the hold-down bracket to the side.
 2. Extend the rear main cylinder approx. 50 mm.
 - The rear cylinder head pulls the roller blocks (**36**) upwards, thereby raising the rail (**8**).
- (Fig. C2.01)



The rear carriage must still be held in place by the anchor tie rods (**52b**). Do not release the top domed nut (**62b**) and hexagonal coupler (**64**)!

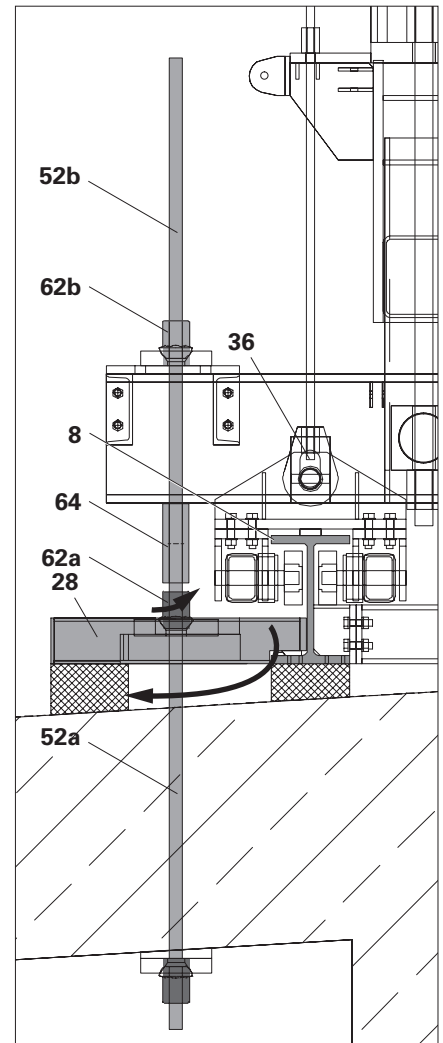

C2 Pushing the rail forward

3. On the front carriage, release the hold-down bracket from the rail. For this, loosen the domed nut on the anchor tie rod and turn the hold-down bracket to the side.
4. Raise the front carriage. To do this, retract the front main cylinder (2), thereby pulling the shoe side guide (37) of the front carriage (31) up against the rail from below.
→ The rail is raised.
→ The rail is now in feed mode.
(Fig. C2.02)

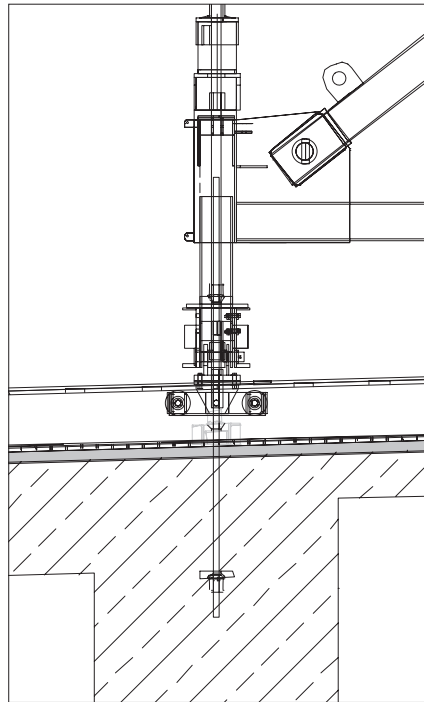

Fig. C2.01

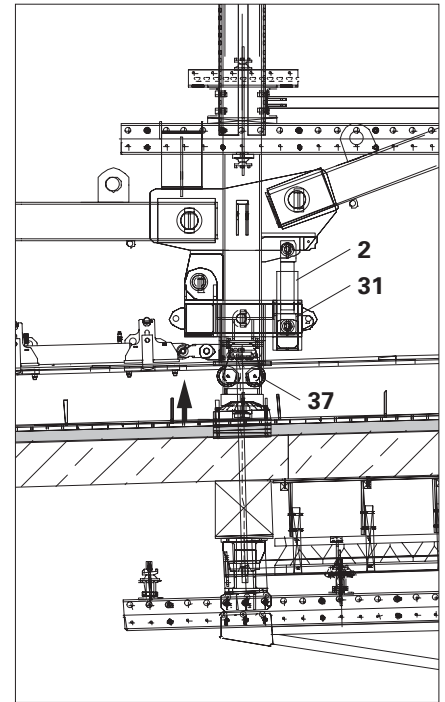

Fig. C2.02

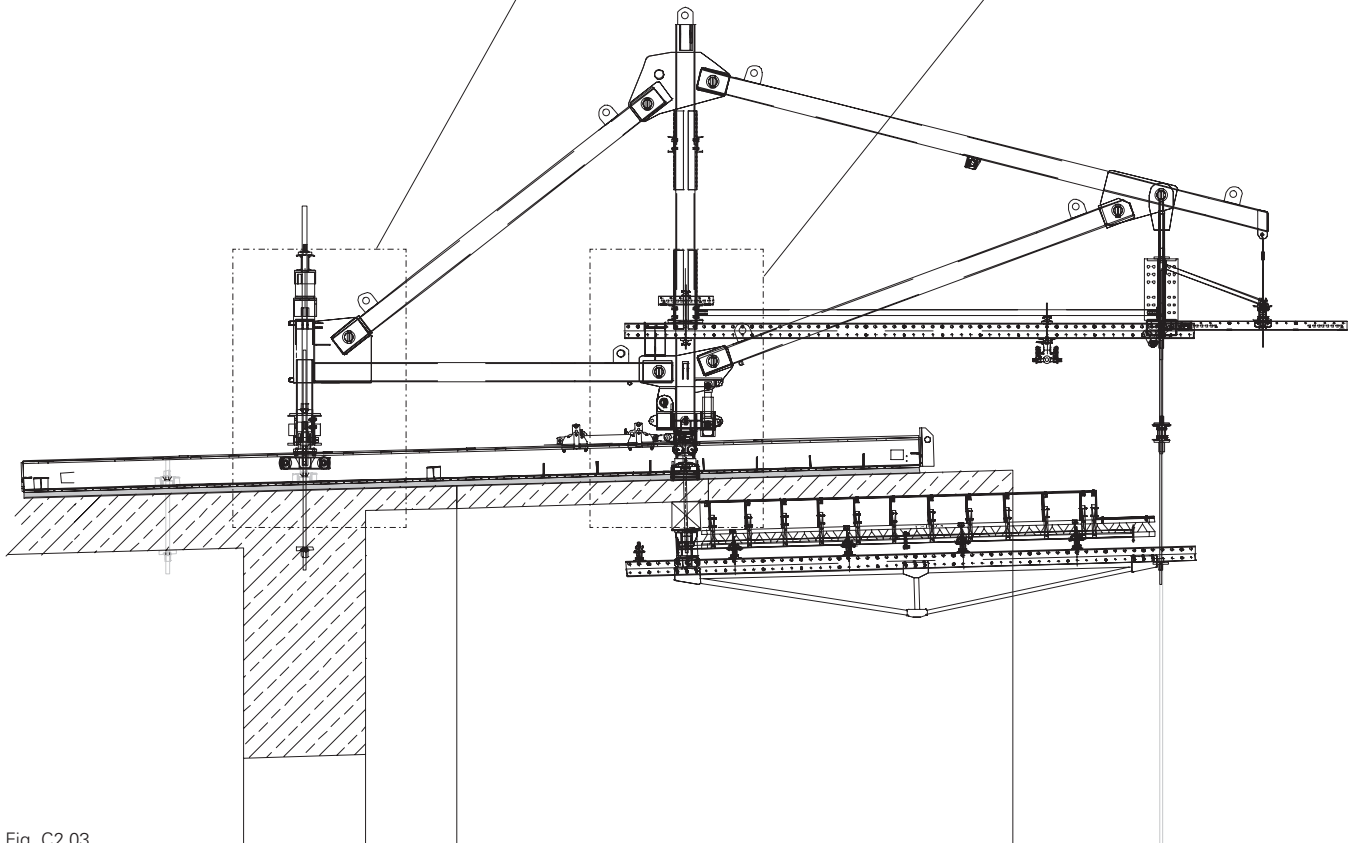

Fig. C2.03

Pushing the rail forward

Components:

- 3** Driving cylinder
- 8** Rail VBC
- 21** Drive Catch Head-2 VBC

Requirements

- Driving cylinder is retracted.
- Locking plates of both drive catch heads are engaged in a section of the rail.

Drive mode

1. Press the release lever (**21.2**) on the drive catch head (**21A**) downwards, thereby lifting the locking plate (**21.1**). (Fig. C2.04)

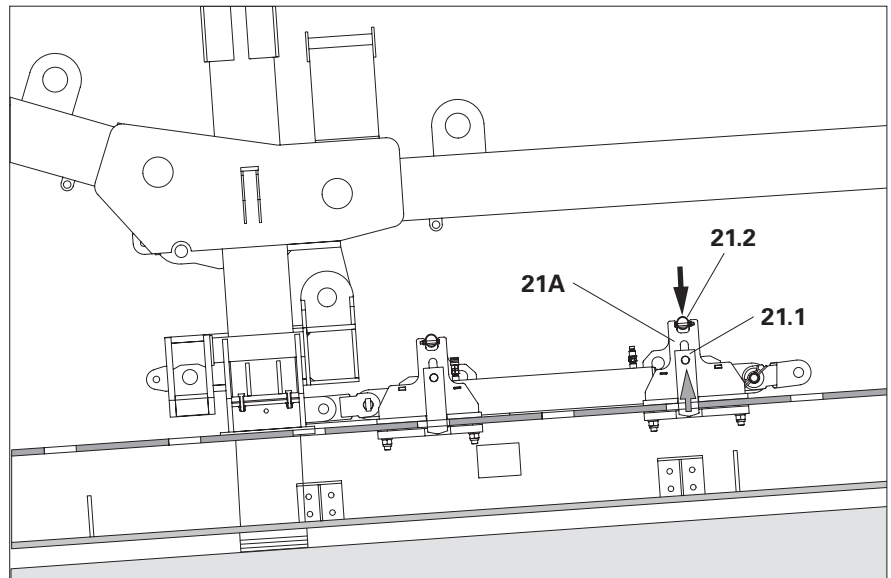

Fig. C2.04

2. Extend the drive cylinder (**3**) to the past section of rail (**8.1**). After leaving the previous section of rail, the release lever can then be released.
 - The rail is held securely by the drive catch head (**21B**).
 - The drive catch head (**21A**) is pushed back on the rail. (Fig. C2.05)

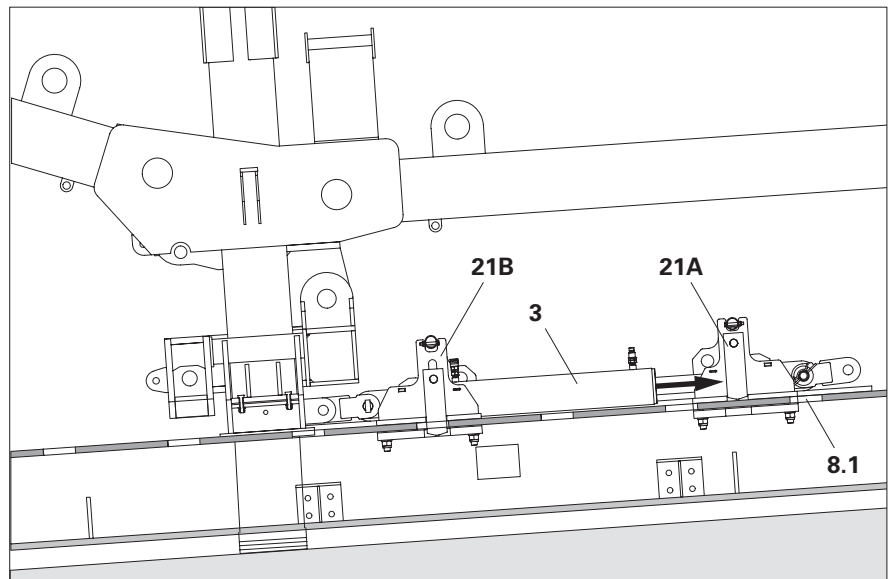

Fig. C2.05

C2 Pushing the rail forward

- The locking plate **(21.1)** drops into the previous section **(8.1)** of the rail.
- 3. Stop the drive cylinder from extending any further. (Fig. C2.06)

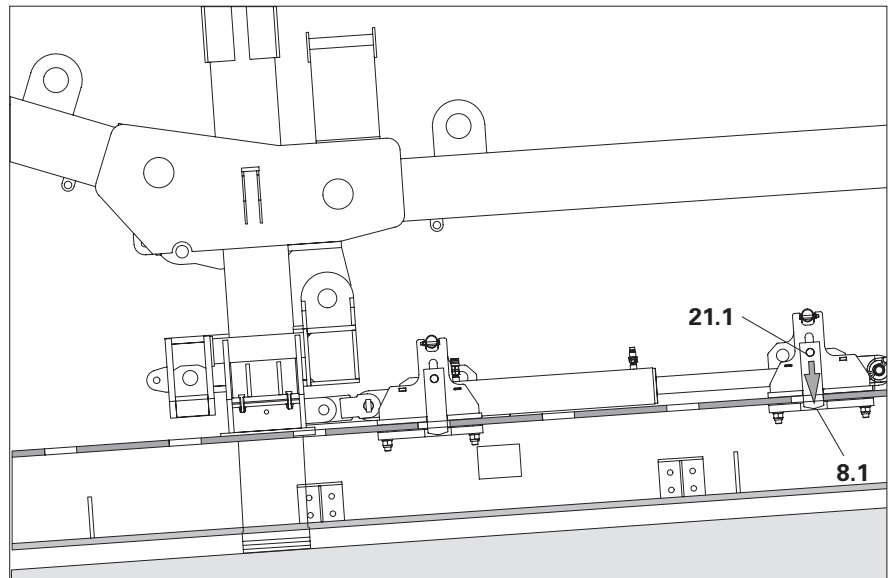

Fig. C2.06

- 4. Press the release lever **(21.2)** on the drive catch head **(21B)** downwards, thereby lifting the locking plate **(21.1)**.
- 5. Retract the drive cylinder **(3)** to the next section of rail **(8.1)**. After leaving the previous section of rail, the release lever can then be released.
 - The rail is pulled forward by the drive catch head **(21A)**. (Fig. C2.07)

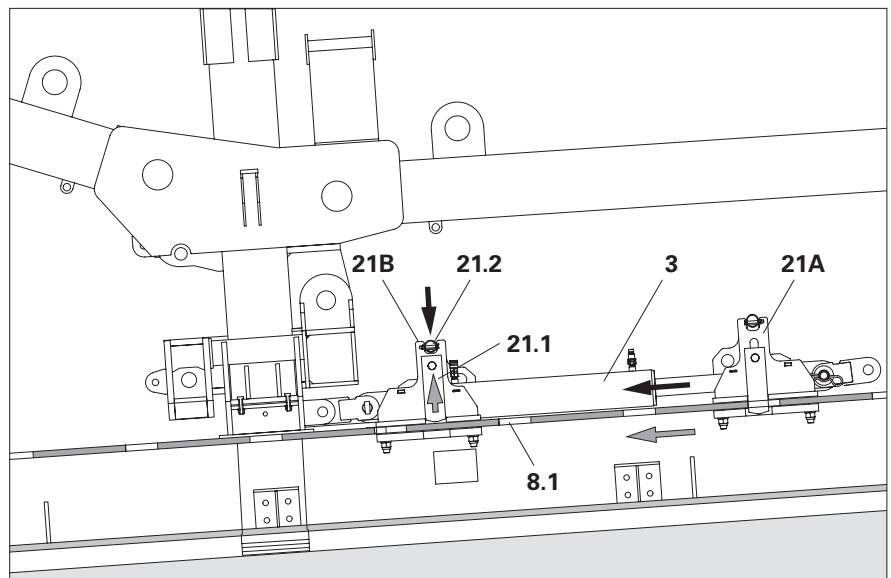

Fig. C2.07

C2 Pushing the rail forward

- The locking plate (21.1) of the drive catch head (21B) drops into the next section (8.1) of the rail.
- 6. Stop the drive cylinder from retracting any further.
- (Fig. C2.08)
- 7. Repeat steps 1 and 6 until the rail has reached its designated position.



End position and anchoring points are found in the project-specific planning.

Subsequent work

1. Lower the front carriage until the rail rests on the structure, see Section "B4 Front carriage" on page 40.
 2. Lower the rear main cylinder carriage until the rail rests on the structure, see Section "B5 Rear carriage" on page 44.
 3. Align the rails parallel to each other.
 4. Turn the rear hold-down bracket to the rail and tighten the domed nut.
 5. Turn the front hold-down bracket to the rail and tighten with the domed nut on the anchor tie rod.
- The rail is anchored.

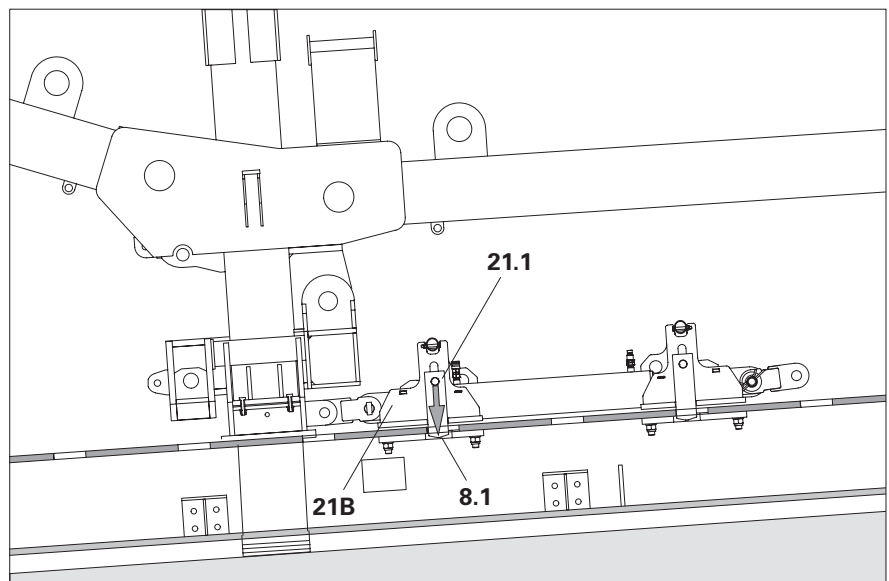

Fig. C2.08

EG-Einbauerklärung



im Sinn der EG-Maschinenrichtlinie 2006/42/EG, Anhang II, Teil 1, Abschnitt B vom 17.05.2006.

Hersteller: PERI SE
Rudolf-Diesel-Straße 19
89264 Weißenhorn
Deutschland

Die speziellen Technischen Unterlagen gemäß EG-Maschinenrichtlinie 2006/42/EG, Anhang VII, Teil B wurden erstellt! Auf begründetes Verlangen werden die speziellen Technischen Unterlagen an die zuständigen staatlichen Stellen übermittelt! Die Übermittlung kann elektronisch oder auf Papier erfolgen! Alle Schutzrechte verbleiben bei o.g. Hersteller.

Die Inbetriebnahme unseres Produktes bleibt so lange untersagt, bis festgestellt wurde, dass die Ausführung der Anlage/ Maschine, in welcher der Einbau erfolgen soll oder von dem es ein Teil sein wird, mit den entsprechenden Rechtsvorschriften übereinstimmt.

Bevollmächtigter für die Zusammenstellung der technischen Unterlagen: PERI SE, GROUP QUALITY
Anschrift siehe Hersteller

Hiermit erklären wir, dass die Bauart und die Ausführung

Unvollständigen Maschine Hydraulikanlage VBC
für das System VARIOKIT Freivorbaugerät VBC
gemäß der Zeichnung DR-23-041907
und der Funktion

Die Komponenten der Hydraulikanlage VBC sind Teil der Hub- und Absenkeinrichtung sowie der Fahrwerke des Freivorbaugeräts VBC. Mit dem Hub und Absenkzylinder VBC 280 kann die auskragende Schalung des Freivorbaugeräts angehoben oder abgesenkt werden. Mit Hilfe des Vorspannzylinders-2 VBC wird die Deckenschalung angehoben und gegen den vorigen Betonierabschnitt gespannt oder gelöst. Mit dem Hinteren und Vorderen Hauptzylinder VBC 280 kann die Fahrschiene des Freivorbaugeräts be- und entlastet werden. Mittels Fahrzylinders VBC 280 als Teil des Fahrwerks wird das Freivorbaugerät bzw. die Fahrschiene schrittweise in Längsrichtung verfahren. Nur das Hydraulikaggregat VBC 280 und die aufgeführten Hydraulikschläuche sind zum Betrieb der Hydraulikzylinder zu verwenden. Die Handpumpe-2 VBC dient zum Betrieb des Vorspannzylinders-2 VBC.

folgenden geltenden Normen und Richtlinien entspricht.

EG-Richtlinie 2006/42/EG Richtlinie 2006/42/EG des Europäischen Parlaments und des Rates vom 17. Mai 2006 über Maschinen

Es wird erklärt, dass die folgenden grundlegenden Anforderungen der Maschinenrichtlinie 2006/42/EG erfüllt sind: 1.1.3, 1.3., 1.3.1, 1.3.2, 1.3.7, 1.3.9, 1.5.1, 1.5.15, 1.6.1, 1.6.3, 1.6.5

Angewandte harmonisierte Normen, insbesondere:

DIN EN ISO 12100: 2011-03	Sicherheit von Maschinen; Allgemeine Gestaltungsleitsätze – Risikobeurteilung und Risikominderung
DIN EN 60204-1: 2019-06	Sicherheit von Maschinen; Elektr. Ausrüstung von Maschinen - Teil 1: Allgemeine Anforderungen
DIN EN ISO 13854: 2020-01	Sicherheit von Maschinen; Mindestabstände zur Vermeidung des Quetschens von Körperteilen
DIN EN ISO 13857: 2020-04	Sicherheit von Maschinen; Sicherheitsabstände gegen das Erreichen von Gefährdungsbereichen mit den oberen und unteren Gliedmaßen
DIN EN 614-1: 2009-06	Sicherheit von Maschinen – Ergonomische Gestaltungsgrundsätze – Teil 1: Begriffe und allgemeine Leitsätze
DIN EN ISO 4413: 2011-04	Fluidtechnik – Allgemeine Regeln und sicherheitstechnische Anforderungen an Hydraulikanlagen und deren Bauteile

Weißenhorn, den 26.07.2023

Deifel, Dieter
2023.07.26 12:24:17 +02'00'

Dieter Deifel
Leiter R&D Civil Engineering

EC-Declaration of incorporation



according with the EC Machinery Directive 2006/42/EC, Annex II, Part 1, Section B of 17.05.2006.

Manufacturer: PERI SE
Rudolf-Diesel-Straße 19
89264 Weißenhorn
Deutschland

The special technical documents according to EC Machinery Directive 2006/42/EC, Annex VII, Part B have been prepared! Upon justified request, the special technical documents will be forwarded to the responsible state authorities! The transmission can be made electronically or on paper! All property rights remain with the above-mentioned manufacturer.

The commissioning of our product remains prohibited until it has been determined that the design of the system/machine in which it is to be installed or of which it will be a part complies with the relevant legal regulations.

Person established in the Community authorized to compile the relevant technical documentation: PERI SE, GROUP QUALITY
Address, see manufacturer

We hereby declare that the design and construction of the

partly completed machinery Hydraulic System VBC
for the system VARIOKIT Balanced Cantilever Carriage
according drawing DR-23-041907
and function

The components of the Hydraulic System VBC are part of the lifting and lowering device as well as the travel units of the VBC cantilever formwork carriage. The Hoist and Lowering Cylinder VBC 280 can be used to raise or lower the cantilevered formwork. With the help of the Pretensioning Jack-2 VBC, the slab formwork is raised and tensioned or released against the previous concreting section. The Rear and Front Main Cylinders VBC 280 can be used to load and unload the travel rail of the cantilever formwork carriage. By means of the Moving Cylinder VBC 280 as part of the travel unit, the formwork carriage or the travel rail is moved stepwise in the longitudinal direction. Only the Hydraulic Pump VBC 280 and the listed hydraulic hoses are to be used to operate the hydraulic cylinders. The Hand Pump-2 VBC is used to operate the Pretensioning Jack-2 VBC.

complies with the following applicable standards and directives.

EC-Directive 2006/42/EC Directive 2006/42/EC of the European Parliament and of the Council, dated 17th of May 2006 on machinery

It is declared that the following essential requirements of the Machinery Directive 2006/42/EC have been fulfilled: 1.1.3, 1.3., 1.3.1, 1.3.2, 1.3.7, 1.3.9, 1.5.1, 1.5.15, 1.6.1, 1.6.3, 1.6.5

Applied harmonised standards, in particular:

DIN EN ISO 12100: 2011-03	Safety of machinery - General principles for design - Risk assessment and risk reduction
DIN EN 60204-1: 2019-06	Safety of machinery - Electrical equipment of machines - Part 1: General requirements
DIN EN ISO 13854: 2020-01	Safety of machinery – Minimum gaps to avoid crushing of parts of the human body
DIN EN ISO 13857: 2020-04	Safety of machinery – Safety distances to prevent hazard zones being reached by upper and lower limbs
DIN EN 614-1: 2009-06	Safety of machinery – Ergonomic design principles – Part 1: Terminology and general principles
DIN EN ISO 4413: 2011-04	Hydraulic fluid power – General rules and safety requirements for systems and their components

Weissenhorn, 2023-07-26

Deifel, Dieter
2023.07.26 12:23:44 +02'00'

Dieter Deifel
Head of R&D Civil Engineering

Hydraulics VBC

Art no. Weight [kg]

132256 316.000 **Hydraulic Set 1 VBC 280**

Consisting of:

- 2 pc. 132243 (65,3kg) Front Main Cylinder VBC 280
- 2 pc. 132244 (74,3kg) Drive Cylinder VBC 280
- 1 pc. 132252 (36,4kg) Transport Box Hydraulic Set-1 VBC

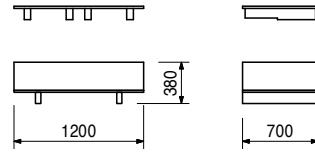
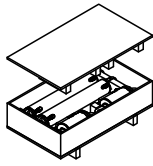

Art no. Weight [kg]

132257 426.000 **Hydraulic Set 2 VBC 280**

Consisting of:

- 2 pc. 132245 (100kg) Rear Main Cylinder VBC 280
- 4 pc. 132246 (46kg) Lifting and Lowering Cylinder VBC 280
- 1 pc. 132253 (36,4kg) Transport Box Hydraulic Set-2 VBC

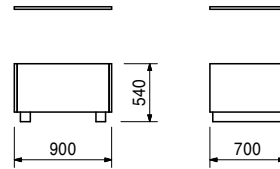
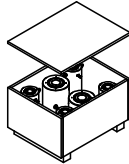

Art no. Weight [kg]

132258 174.000 **Hydraulic Set 3 VBC 280**

Consisting of:

- 4 pc. 132249 (29,9kg) Pre-Tensioning Jack-2 VBC
- 4 pc. 132250 (5,7kg) Hand Pump-2 VBC
- 1 pc. 132254 (35,5kg) Transport Box Hydraulic Set-3 VBC

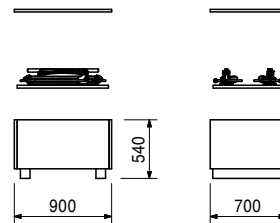
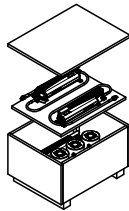

Art no. Weight [kg]

132255 271.000 **Hydraulic Pump Set VBC 280**

Consisting Pump:

- 1. pc. 132242 (208,5kg) Hydraulic Pump VBC 280
- 1. pc. 132251 (62kg) Transport Box Pump VBC 280

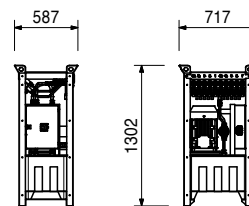
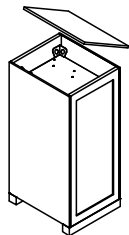

Accessory (not included)

132248	0.250	Power Socket VBC 280 16A
132247	0.944	Powercable VBC 280 CEE-16A-200
133758	0.850	Return Filter Pump VBC 280

Hydraulics VBC

Art no. Weight [kg]

133758 0.850 **Return Filter Pump VBC 280**

Spare oil filter for the Hydraulic Pump VBC 280.

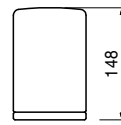
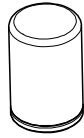

Art no. Weight [kg]

132247 0.944 **Powercable VBC 280 CEE-16A-200**

For connecting the Hydraulic Pump VBC to the power supply system.

Notes

With CEE socket 400 V, 16 A with manual phase inverter.
Cable length: 2m.

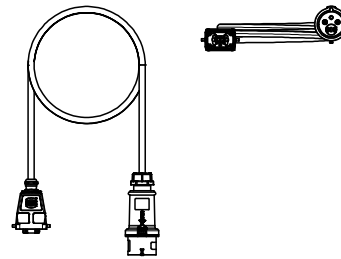
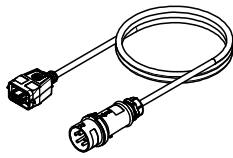

Art no. Weight [kg]

132248 0.250 **Power Socket VBC 280 16A**

Power socket for making a connection cable for the Hydraulic Pump VBC by an electrician.

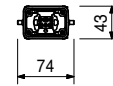

Hydraulics VBC

Art no. Weight [kg]

Hydr.Oils ISO11158 in drum

131270	17.900	Hydr.Oil ISO11158 HM10 20I
131274	18.300	Hydr.Oil ISO11158 HVI22 20I
137373	18.300	Hydr.Oil ISO11158 HVI32 20I
057376	18.300	Hydr.Oil ISO11158 HVI46 20I

High-quality synthetic hydraulic oils for PERI Hydraulic Power Units with different viscosity suitable for certain temperature ranges.

Notes

Filter with filter pump before filling the aggregates.

Observe Safety Data Sheet and applicable National Safety Regulations regarding hydraulic oil, in particular for transport, storage and disposal! Observe the technical documentation for the hydraulic power unit! Product Data Sheet on request.

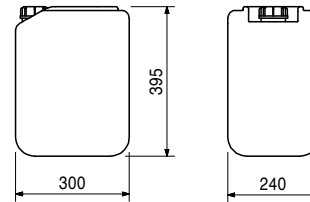

Art no. Weight [kg]

Hydr.Oils ISO11158 in canister

131273	200.000	Hydr.Oil ISO11158 HM10 210I
131275	200.000	Hydr.Oil ISO11158 HVI22 210I
137374	201.000	Hydr.Oil ISO11158 HVI32 210I
131277	201.000	Hydr.Oil ISO11158 HVI46 210I

High-quality synthetic hydraulic oils for PERI Hydraulic Power Units with different viscosity suitable for certain temperature ranges.

Notes

Filter with filter pump before filling the aggregates.

Observe Safety Data Sheet and applicable National Safety Regulations regarding hydraulic oil, in particular for transport, storage and disposal! Observe the technical documentation for the hydraulic power unit! Product Data Sheet on request.

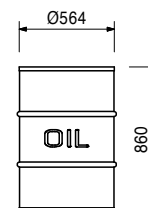

Hydraulics VBC

Art no.	Weight [kg]	
137281	14.000	Hydr.Oil Filter Pump CE

Filter pump for quick and clean transfer of hydraulic oil with simultaneous filtration.

Notes

Follow Instructions for Use!
Power connection 220V/50Hz, plug CEE 7/7

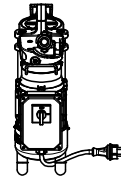
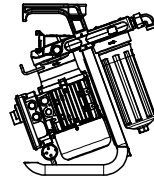
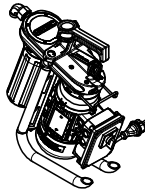

Accessory (not included)

137282	1.000	Hydr.Oil Filterelement 500
137283	1.000	Suction-/Pressure Hose 250

Art no.	Weight [kg]	
137282	1.000	Hydr.Oil Filterelement 500

Wear part of the Hydr.Oil Filter Pump CE.

Notes

Follow Instruction for use!
Observe the maintenance instructions in the technical documentation for the oil filter pump!
Observe disposal instructions!

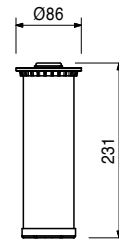
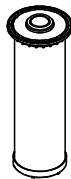

Art no.	Weight [kg]	
137283	1.000	Suction-/Pressure Hose 250

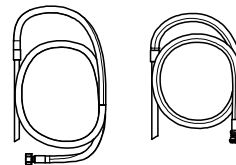
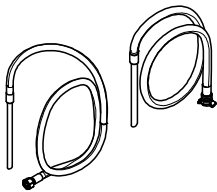

Art no.	Weight [kg]	
130685	0.225	Universal Funnel

For easy filling of hydraulic pumps with oil.

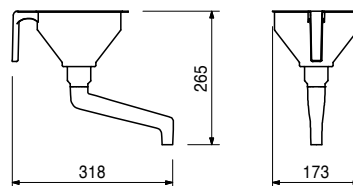

Hydraulics VBC

Art no.	Weight [kg]		L [mm]	X [mm]
Hydr.Hoses 853-2SN-DN08-FF				
129035	0.996	Hydr.Hose 853-2SN-DN08-FF 1m	1169	1000
129036	1.430	Hydr.Hose 853-2SN-DN08-FF 2m	2169	2000
129419	2.690	Hydr.Hose 853-2SN-DN08-FF 5m	5170	5000
129420	4.900	Hydr.Hose 853-2SN-DN08-FF 10m	10170	10000
129421	7.120	Hydr.Hose 853-2SN-DN08-FF 15m	15170	15000
129422	9.330	Hydr.Hose 853-2SN-DN08-FF 20m	20170	20000

Hydraulic hoses with quick couplings and nominal diameter 8mm.

Notes

Follow applicable Safety Regulations for the installation and maintenance of hydraulic lines!

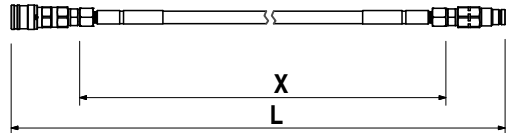
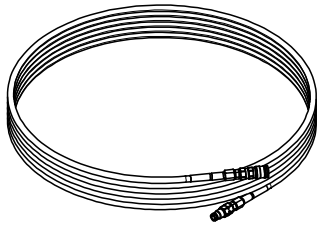

Consists of

- 1 pc 128992 Pin ISO16028 DN10 R3/8IG
- 1 pc 128993 Sleeve ISO16028 DN10 R3/8IG
- 2 pc 051750 Male Stud Coupl. X-GE12PSR-ED

Art no.	Weight [kg]	
Hydr.Twin Hoses RCS		
110069	8.500	Hydr.Twin Hose RCS 10m
110070	15.300	Hydr.Twin Hose RCS 20m

Two permanently connected hydraulic hoses for connecting hydraulic pumps with hydraulic climbing devices.

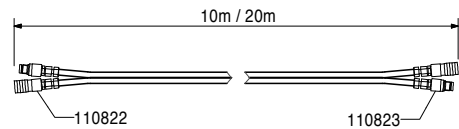
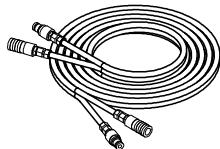

Consists of

- 2 pc 128992 Pin ISO16028 DN10 R3/8IG
- 2 pc 128993 Sleeve ISO16028 DN10 R3/8IG
- 4 pc 051750 Male Stud Coupl. X-GE12PSR-ED

Art no.	Weight [kg]	
126646	0.651	Bypass Hose RCS

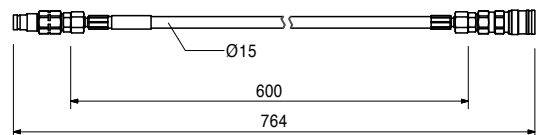
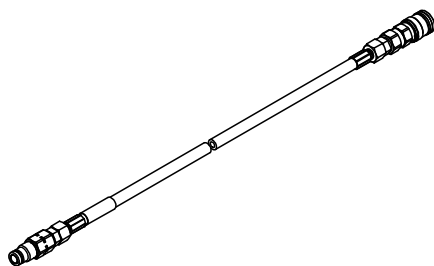

Hydraulics VBC

Art no.	Weight [kg]	
129423	1.370	Hydr.T-Piece 2SN-DN08-FF

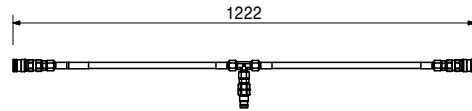
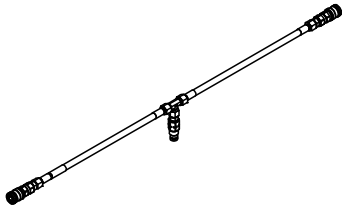

Consists of

- 1 pc 128992 Pin ISO16028 DN10 R3/8IG
- 2 pc 128993 Sleeve ISO16028 DN10 R3/8IG
- 3 pc 051750 Male STUD Coupl. X-GE12PSR-ED

Art no.	Weight [kg]	
112421	3.000	Hydr. Accum. Piece RCS

To double the volume of the oil at the Hydraulic Pump RCS. Also doubles the speed of the Hydraulic Winch RCS.

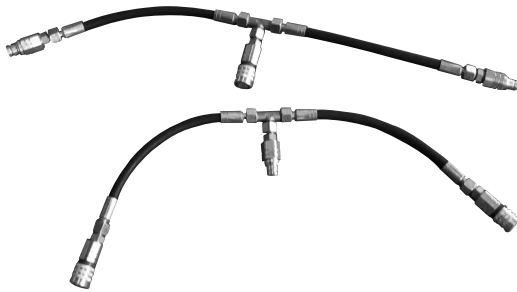

Art no.	Weight [kg]	
137400	0.350	Hydr.Hose 2SN DN8 65 90°

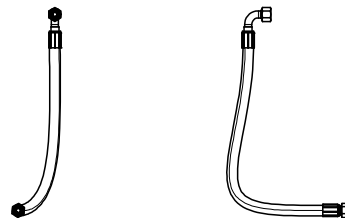
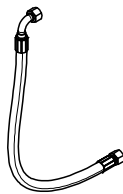

Art no.	Weight [kg]	
137346	0.007	Cable Binder 7,8x540mm

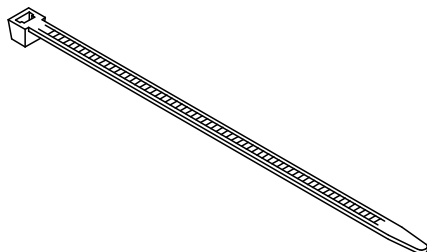

Hydraulics VBC

Art no.	Weight [kg]	
129424	0.440	FF-Coupling Pair X-GE12PSR-ED+

Spare parts set for PERI Hydraulic Components with quick couplings X-GE 12PSR-ED+.

Notes

For assembling on hydraulic hoses EN853-2SN-DN08.

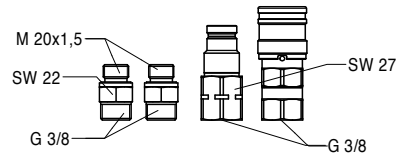
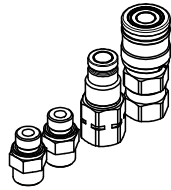

Consists of

- 1 pc 128992 Pin ISO16028 DN10 R3/8IG
- 1 pc 128993 Sleeve ISO16028 DN10 R3/8IG
- 2 pc 051750 Male Stud Coupl. X-GE12PSR-ED

Art no.	Weight [kg]	
110823	0.171	Quick Coupler Nipple RCS

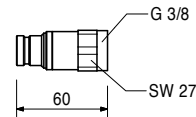

Art no.	Weight [kg]	
110822	0.297	Quick Coupler Bushing RCS

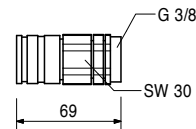
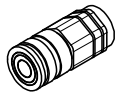

Art no.	Weight [kg]	
125632	0.050	Prot. Covers Climb. Device RCS

Spare part.
To protect unplugged quick couplings against dirt and damage.

Notes

Use with hydraulic hoses with FF couplings possible.
1 set for 1 Climbing Device RCS 50 (2x bushing and 2x nipple each).

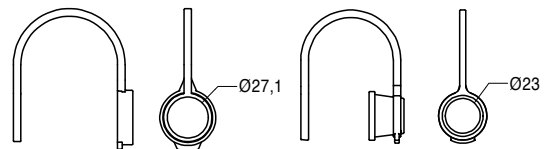
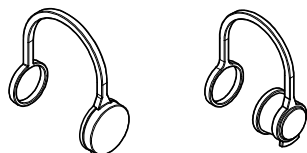

Hydraulics VBC

Art no. Weight [kg]

115581 10.280 **Service Box Hydraulics**

Consisting of:

- 1 pc. 115590 Tool Box 580x260x285mm
- 6 pc. 115583 Pressure Gauge Typ 570 VA-Geh.
- 6 pc. 115584 Hose MKT 6-02 DN 02
- 12 pc. 115582 Measuring Coupl. SMK 20-G 1/4-PC
- 2 pc. 115591 Double Spanner SW10x13
- 1 pc. 115592 Double Spanner SW13x17
- 1 pc. 135172 Double Spanner SW19x22
- 1 pc. 115588 Double Spanner SW19x24
- 1 pc. 051778 Double Spanner SW24x27
- 1 pc. 115589 Double Spanner SW27x32
- 1 pc. 057278 Allen Key Set 8 pcs.
- 1 pc. 115585 Allen Key SW12
- 1 pc. 057279 Allen Key SW14
- 1 pc. 057282 Pipe Wrench
- 1 pc. 115147 Angle Fitting Set PS
- 2 pc. 115396 Fitting Set PS RCS short
- 1 pc. 072180 Ratchet Wrench 1/2"
- 20 pc. 123881 Tube Screw Plug ROV12SX
- 20 pc. 123880 Threaded Plug VKAN 12S VIT
- 100 pc. 051760 Cable Binder NT-240H
- 2 pc. 126425 Distance Piece Ø120mm coat
- 1 pc. 126440 Socket SW17 1/2"
- 1 pc. 135173 Allen Key SHR-Bit SW05
- 1 pc. 135174 Allen Key SHR-Bit SW06
- 1 pc. 135175 Allen Key SHR-Bit SW08
- 1 pc. 135176 Allen Key SHR-Bit SW10
- 1 pc. 135177 SHR Screwdriver Bit 6 parts Slot/PH
- 2 pc. 711035 PERI Label 128x65mm
- 1 pc. 126434 List of contents Hydraulic Service Case

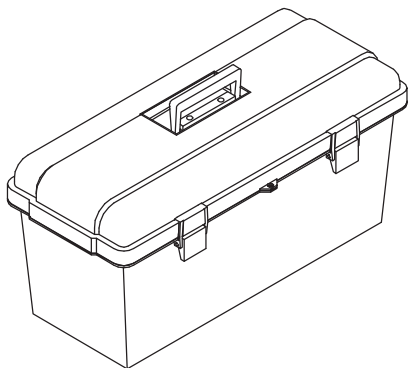

The optimal system
for every project and
every requirement



Wall formwork



Column formwork



Slab formwork



Climbing systems



Bridge formwork



Tunnel formwork



Shoring systems



Construction scaffolds



Façade scaffolds



Industrial scaffolds



Access



Safety scaffolds



Safety systems



System-independent accessories



Services



PERI Danmark A/S
Forskalling & Stilladssystemer
Greve Main 26
2670 Greve
Tlf. +45 4345.3627
peri@peri.dk
www.peri.dk

